

A. EMERY.
NARROW WARE LOOM.
APPLICATION FILED JULY 15, 1912.

1,057,133.

Patented Mar. 25, 1913.

3 SHEETS—SHEET 1.

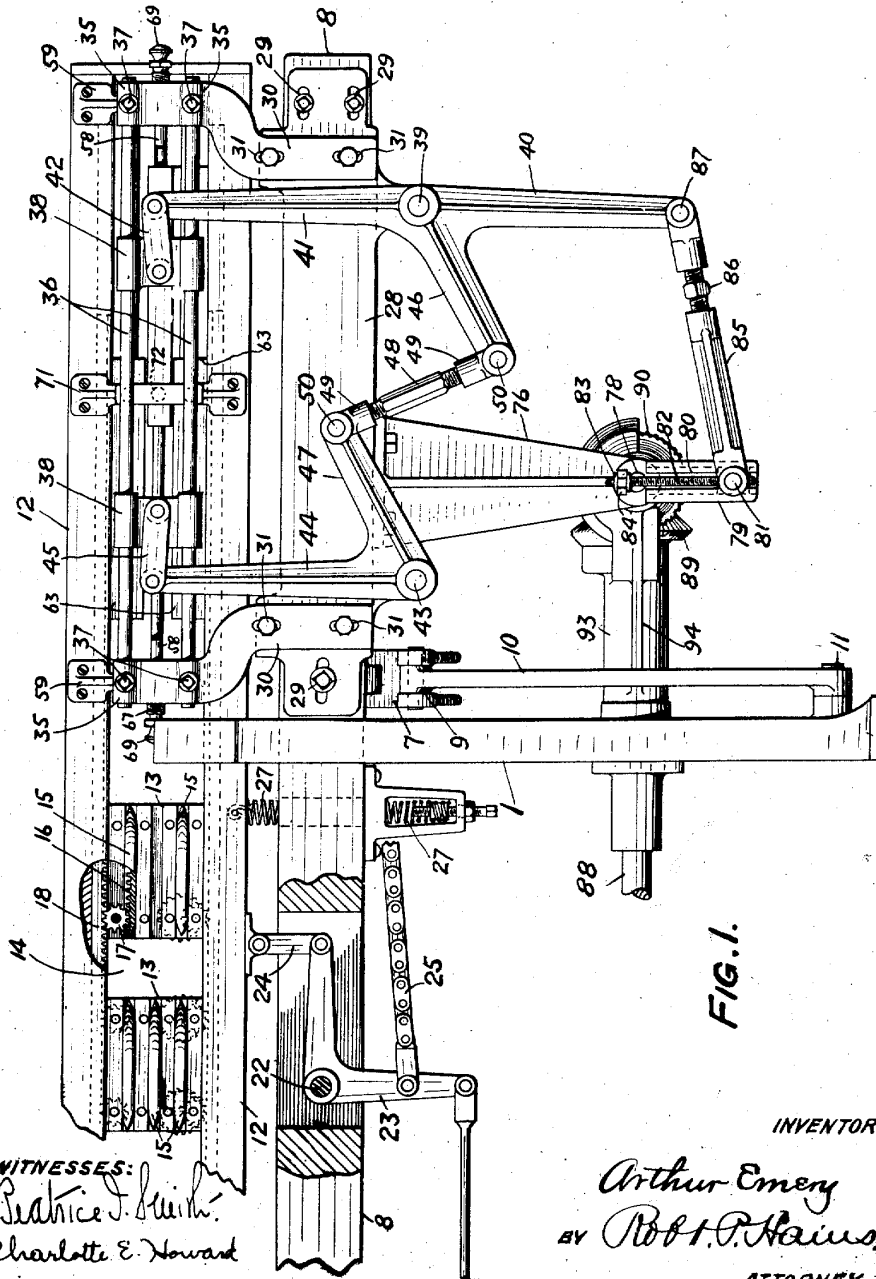

A. EMERY.
NARROW WARE LOOM.
APPLICATION FILED JULY 15, 1912.

1,057,133.

Patented Mar. 25, 1913.

3 SHEETS—SHEET 2.

FIG. 3.

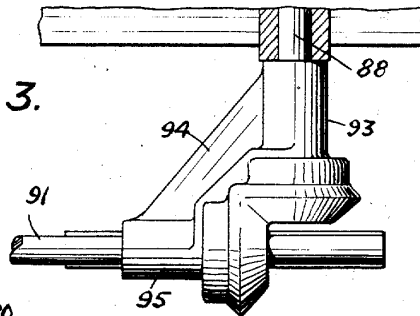
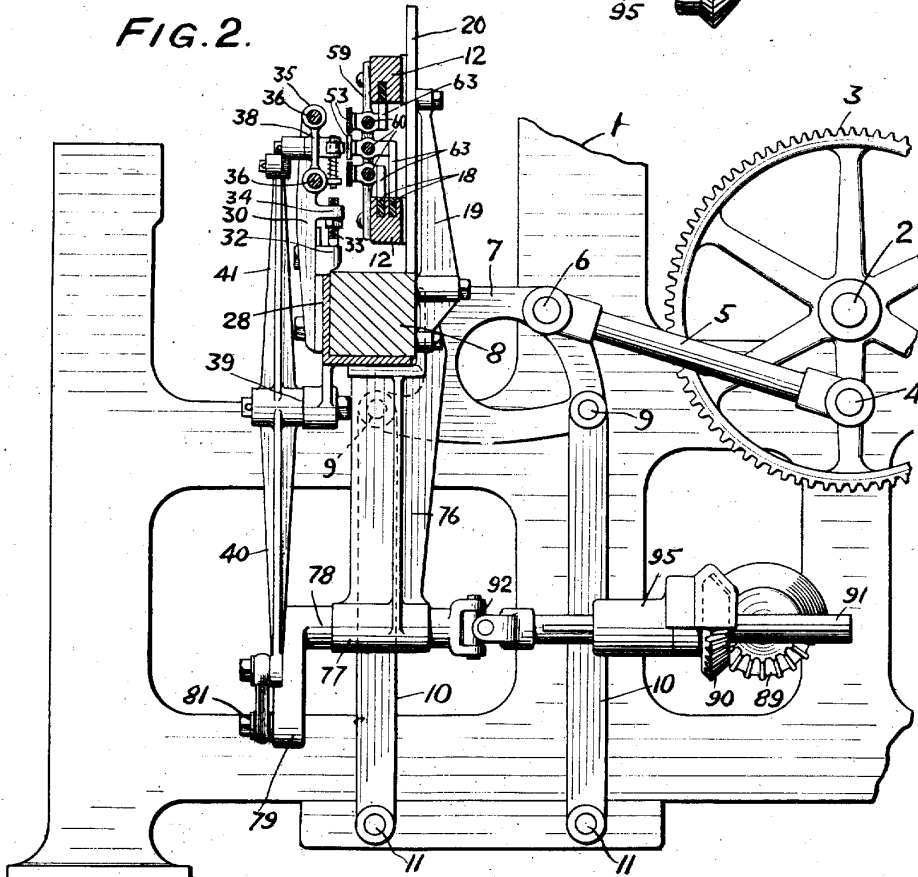

FIG. 2.



INVENTORS

WITNESSES:

Patrick J. Bush
Charlotte E. Howard

Arthur Emery
BY Robt. V. Hains

ATTORNEY.

A. EMERY.
 NARROW WARE LOOM.
 APPLICATION FILED JULY 15, 1912.

1,057,133.

Patented Mar. 25, 1913.

3 SHEETS—SHEET 3.

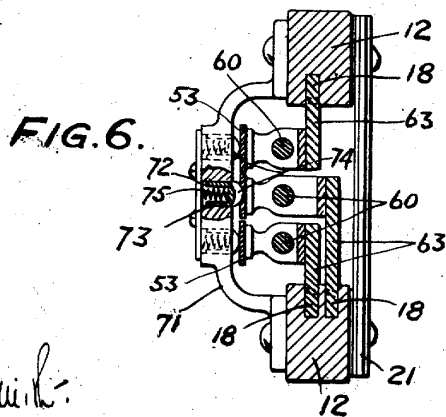
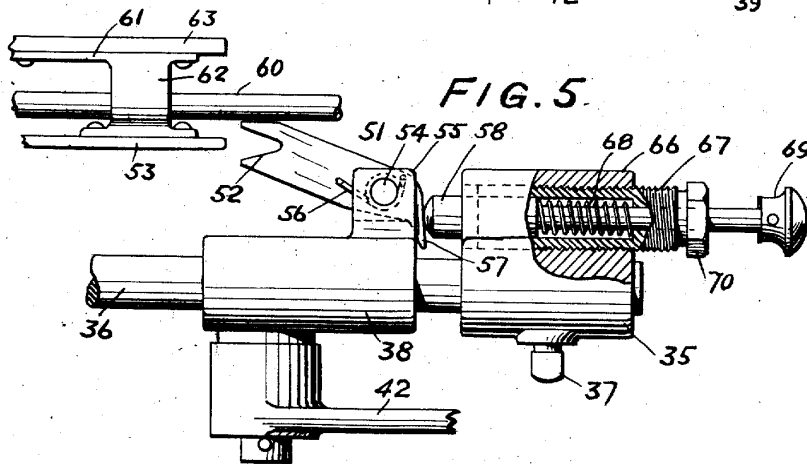
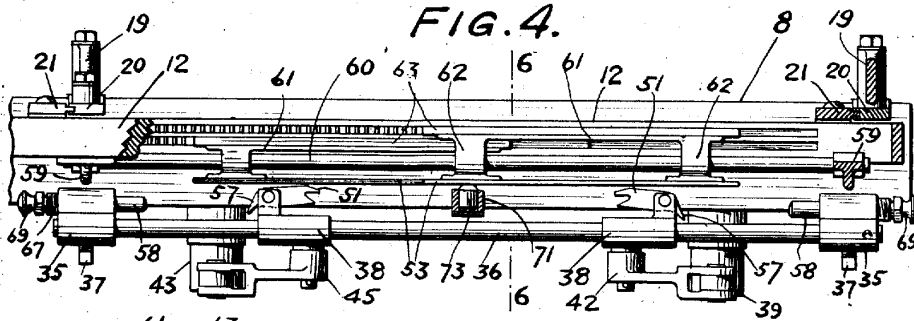

WITNESSES:
Beatrice J. Smith
Charlotte E. Howard

INVENTORS
Arthur Emery
 BY *Robt. T. Haines*
 ATTORNEY.

UNITED STATES PATENT OFFICE.

ARTHUR EMERY, OF PHILADELPHIA, PENNSYLVANIA, ASSIGNOR TO SCHAUM AND UHLINGER, INCORPORATED, OF PHILADELPHIA, PENNSYLVANIA, A CORPORATION OF PENNSYLVANIA.

NARROW-WARE LOOM.

1,057,133.

Specification of Letters Patent. Patented Mar. 25, 1913.

Application filed July 15, 1912. Serial No. 709,319.

To all whom it may concern:

Be it known that I, ARTHUR EMERY, a citizen of the United States, residing at Philadelphia, in the county of Philadelphia and State of Pennsylvania, have invented an Improvement in Narrow-Ware Looms, of which the following description, in connection with the accompanying drawings, is a specification, like letters on the drawings representing like parts.

The invention to be hereinafter described relates to narrow ware looms, and more particularly to shuttle motions of such looms, whereby the series of shuttles are moved to lay filling or weft in the sheds of the fabrics being woven.

As well known by those skilled in the art, looms of this generic character have been devised to weave a series of narrow fabrics side by side, and if desired, such fabrics may have different characters or colors of filling or weft, in which event a plurality of banks or series of shuttles are employed, and the bank or series of shuttles having the desired character or color of filling is brought into play as dictated by the pattern of the fabrics being woven; or a plurality of fabrics may be woven in vertical relation. In any event, the shuttles of each series are moved across the warp space of their respective fabrics to lay the filling or weft, and various means have been devised to impart desired movement to the shuttles.

The aims and purposes of the present invention are to simplify, render more effective and positive, and generally to improve the means for giving to the series of shuttles the movements above-noted whereby filling is laid in the shed of the fabrics being woven, all of which will best be made clear from the following description and accompanying drawings of one form of such means, it being understood that the invention is not circumscribed by the details thereof, but in its true scope is pointed out by the claims.

In the drawings:—Figure 1 is a front elevation of one end of the loom, showing the lay or batten and its associated elements, parts being broken away. Fig. 2 is a side elevation at the same end of the loom, showing more particularly the lay or batten, its mounting, the actuating means therefor,

and the devices carried thereby, the latter being partly shown in section. Fig. 3 is a detached detail showing the driving connection between the shuttle actuating shaft and the under shaft of the loom. Fig. 4 is a top or plan view of one end of the batten or lay, showing features of the present invention, parts being broken away. Fig. 5 is an enlarged detail showing the action of the picker fingers, yielding plunger, and picker blade. Fig. 6 is a cross-section on line C—C, Fig. 4.

In the drawings, the loom frame 1 may be of any usual construction suitable for supporting the operative parts. Mounted on the loom frame is the crank-shaft 2, which may be driven from any suitable source of power as usual, and connected thereto is the pinion 3, to which is jointed at 4 the pitman 5, the other end of which is connected at 6 to a bracket 7 secured to the lay beam or batten 8. To the lower portions of the bracket 7 are pivotally connected at 9 the links 10, which at their lower ends are pivotally sustained, as at 11 upon the loom frame, the construction being such that upon rotation of the crank-shaft 2 the lay or batten 8 will be given a movement toward and from the front of the loom, the lay or batten during such movement maintaining its vertical or operative position, as will be well understood by those skilled in the art.

Mounted on the lay or batten 8 through the agency of any suitable means is the auxiliary batten 12, which carries the series of shuttle races 13 separated by a space through which pass the warp threads which form the warp of one or more of the narrow fabrics being woven.

The shuttles 15 which carry the weft or filling to be laid in the shed formed in the warp threads, are or may be provided with the usual rack teeth 16 engaged by suitable pinions 17, as indicated in Fig. 1, which pinions may be operated at the desired times through the usual racks 18 to impart to the shuttles their prescribed or desired movements, through the shed of the warp threads, as usual in this character of devices.

In the present form of the invention there is shown three banks or series of shuttles,

and for each series of shuttles there is a separate rack 18, as indicated by Figs. 2 and 6, said racks being appropriately connected, as will hereinafter appear, to their respective pinions 17 to impart to the shuttles the desired movement to lay the filling in the shed.

In the form of the invention herein illustrated, the auxiliary batten 12, Fig. 1, is mounted upon the lower batten or lay 8 so as to have rising and falling movement with relation thereto, and as one means to this end, brackets 19 (Figs. 2 and 4) extend upward from the rear of the batten 8 and are provided with guideways 20 which engage complementary guideways 21 secured to the rear of the auxiliary batten 12. Mounted upon the batten 8, Fig. 1, at 22, is a bell-crank-lever 23, having a link connection 24 with the auxiliary batten 12, said bell-crank-lever being likewise connected by a chain or other flexible device 25 with suitable pattern mechanism, not necessary herein to be described, since it forms no part of the present invention. A spring 27, (Fig. 1) normally tends to lower the auxiliary batten, the construction being such that under demand of the pattern, and through the connection 25 and bell-crank 23 the auxiliary batten may be raised or lowered to bring the appropriate bank or series of shuttles into the line of the race or shed of the warp thread.

In the form of the invention shown, the narrow fabrics being woven side by side are adapted to have different characters or colors of filling laid in the shed of the respective warp threads to vary the pattern or color effects, and through the pattern connection hereinbefore described, the rising and falling movement of the auxiliary batten determines which one of the banks or series of shuttles shall be brought into the line of the race or shed, to have its appropriate filling laid in the fabric. It will not be necessary to go further into the details of means for moving the auxiliary batten in the manner stated, because such means form no part of the present invention, and are herein shown only in so far as illustrative of one of the applications of the present invention, it being understood that the invention to be herein described is applicable to any character of narrow ware loom whether the fabrics produced thereby be figured or plain, or produced in one or more vertical series.

Mounted on the batten 8 is a plate 28 (see Fig. 1), adapted to be adjusted longitudinally thereof by means of appropriate slot and bolt connections 29, Fig. 1. Adjustably mounted at each end portion of the plate 28 is a bracket 30, the adjustable connection between the brackets 30 and the plate 28 being preferably secured by the slot

and bolt connection 31, Fig. 1. In order to effect adjustment of the brackets 30 on the plate 28 a suitable shoulder 32, Fig. 2, is preferably formed on the plate 28 and against this rests the end of an adjusting screw 33 passing through a lug 34 extending from each of the brackets 30 and held in adjusted position by means of a suitable set nut. Obviously various means might be employed for connecting the brackets 30 to the beam or lay 8, but the above-described means has been found convenient as a good, practical form of such devices. The brackets 30 extend upward and have suitable socketed end portions 35 in which are held the end portions of guide rods 36, there being preferably two of such guide rods extending between the brackets 30 as indicated in Figs. 1 and 2, such guide rods being held in position by suitable means such as the set screws 37, or the like. Mounted to slide upon the guide rods 36 are the picker slides 38, said picker slides 38 having appropriate sleeve portions for engaging the guide rods 36, as will be clear from Figs. 1 and 2.

Pivotaly mounted at 39 upon the batten 8 or a projection from the plate 28 carried by the batten, is the picker lever 40, having an arm 41, the upper end of which is connected to the picker slide 38 by means of a link 42 pivoted to the upper end of said arm 41, and to the picker slide. Similarly pivoted at 43 to the batten 8 or a projection of the plate 28 carried by the batten is the picker lever 44 connected at its upper end by a link 45 to the other picker slide 38, said link 45 being suitably pivoted to the lever 44 and to its picker slide 38. Projecting from the respective picker levers 40 and 44 are the arms 46 and 47 respectively which are connected at their free ends by the adjustable connection 48, Fig. 1, said adjustable connection 48 being preferably formed by a turn-buckle or similar device, whereby the relation of the picker levers 40 and 44 may be appropriately changed as desired. In the present form of the invention the turn-buckle 48 preferably comprises end portions oppositely screw-threaded into appropriate sockets 49 pivotaly connected at 50 to the arms 46 and 47.

From the construction thus far described it will be apparent that if motion be imparted to one of the picker levers, such motion will cause such picker levers to move around their respective fulcrums toward and from each other so as to carry the picker slides 38 into similarly movable relation; and while the vertical picker levers and their adjustable connection as herein shown and described have been found of good practical form, it is to be understood that the invention is not limited or circumscribed by the details of such levers and their connections, the essential being that suitable

means be provided to impart to the picker slides 38 movements toward and from each other, for purposes as will presently appear.

Pivotaly mounted upon each of the picker slides 38 is a picker finger 51, each of said picker fingers having a notched or jaw portion 52 (Figs. 4 and 5) which is adapted to engage, as will hereafter appear, with the end portion of a picker blade 53, suitably connected, one to each of the racks for actuating the shuttles. In the present form of the invention, each of the picker fingers 51 is pivotaly mounted at 54 to a lug 55 projecting rearwardly from its slide 38, and a suitable spring, as 56, normally tends to hold the notched end 52 of the picker finger closed upon the face or back of the picker slide 38. In the present form of the invention, the spring 56 is shown as coiled about the pivotal portion of the picker finger 51, one end of the spring being connected to the lug 55 and the other end of the picker finger, but obviously various forms of this feature of the invention might be employed, the characteristic of this portion of the device being that a suitable yielding means normally acts upon the fingers 51 to hold them closed upon the back face of their respective picker slides 38.

Each of the picker fingers 51 has a projecting tail portion 57, (Figs. 4 and 5) which, as the picker slides 38 are moved into separated relation, are adapted to engage a yielding follower or plunger 58, the construction being such that when the tail portion 57 of a picker finger engages its coacting plunger, the picker finger will be turned upon its pivot 54 and its notched portion 52 will be thrown outward from the picker slide 38, substantially into the position indicated by Fig. 5. Upon movement of the picker slides relatively toward each other, the notched portion 52 of the picker fingers will be in position to engage the end of a picker blade 53, provided such picker blade be in position to permit such engagement, as will presently appear.

It is appropriate at this time to describe the picker blades and their association, each with a rack 18 for moving the shuttles. Secured to the upper and lower rails of the auxiliary batten 12 are the brackets 59 (Figs. 2 and 4), one of said brackets being disposed substantially opposite each of the brackets 30, hereinbefore described. Extending between and secured to each of the brackets 59 are the guide rods 60, three in the present form of the invention, one for each of the banks of shuttles, see Fig. 2. These guide rods 60 may be secured to the brackets 59 in any approved manner and each has mounted thereon a picker plate slide 61, said slide being preferably formed as indicated in Figs. 4 and 5, that is each picker plate slide has an end sleeve portion

62 embracing one of the guide rods 60 and a web at the rear connecting such sleeve portion 62, said web being connected in turn by an arm or plate 63 (Fig. 2) to one of the racks 18. Each of these picker plate slides carries a picker plate 53 which is less in length than the distance between the picker slides 38 when said picker slides are at their maximum degree of separation, it being understood that there is no normal connection between the picker plates and the picker fingers or the picker slides 38.

From the construction thus far described, it will be apparent that as the picker slides 38 are moved by their connected picker levers into their maximum separated positions, the tail portion 57 of each of the picker fingers 51 will engage its coacting plunger 58 with the result that the picker finger thus engaged, will have its notched end 52 thrown outward against the tensions of the spring 56, and should a picker plate 53 be in the path of movement of the picker finger 51 as indicated in Fig. 5, said finger 51 will engage the end of the picker plate, and upon movement of the picker slides toward each other will carry with it the engaged picker plate, and through the connections therewith, move the connected rack 18 and the shuttles operated thereby. On the next separating movement of the picker slides 38 the picker fingers 51 when free from the picker plate will move into close relation with the slides 38 until they approach their outer positions, whereupon they will engage by their tail portions 57 their coacting plungers 58 and have their notched portions 52 thrown outward into position to again engage the end portion of a picker plate when the picker slides 38 are again moved toward each other. Thus during the operation of the loom a picker finger 51 when thrown outward into the position indicated by Fig. 5, will engage the end of a picker plate if such picker plate be in position for such engagement, and will move such picker plate to the other limit of the picking movement, and then leave it disconnected and free from mechanical control.

In order that the picker fingers when thrown outward into the position indicated by Fig. 5 for engaging with the picker plate may remain in said position as the picker slides again move toward each other at the commencement of such movement, the follower or plunger 58 is made yielding, so that it will follow up the tail portion 57 and hold the finger 51 in outward position until it has engaged the end portion of the picker plate, should such picker plate be in position for such engagement; and thereafter, as the picker slides 38 move still farther from their outer positions, the notched portions 52 will maintain themselves in engagement with the engaged picker plate.

Various forms of yielding follower or plunger may be employed to effect the characteristic function hereinbefore noted, but in the present form of the invention a convenient construction is found illustrated by Fig. 5, wherein the brackets 30 each carry a perforated portion 66 internally screw-threaded to receive the adjusting screw-threaded sleeve 67. Within the adjusting sleeve 67 works the plunger 58, a spring 68 being interposed between the head of the plunger and an appropriate shoulder in the adjusting sleeve 67. The plunger is also preferably provided with a head 69 by which it may be manually withdrawn or held in retracted position in order that the picker fingers 51 may not engage the picker plate when it is desired to operate the loom experimentally, or for other purposes, without moving the shuttles. It will be noted that by appropriate manipulation of the heads 70 of the adjusting sleeve 67, the relation of the end of the plunger 58 with the tail of the picker fingers may be properly timed and regulated.

In the present form of the invention, as hereinbefore noted, each of the picker slides 38 carries a single picker finger and the auxiliary batten 12 is raised and lowered under the pattern control to bring any one of the three or more picker plates 53 into the line of action of the picker fingers 51, the loom of the present illustration being intended for the production of narrow fabrics having a pattern formed by different characters or colors of filling. It is to be understood, however, that the present invention is not restricted in its use to the particular form of loom herein illustrated, and that it may be applied as a shuttle motion in a narrow ware loom having two, three, four or more banks of shuttles or battens or to what is known as a two-bank double deck batten. In the last-named case, two or more fabrics will be formed in vertical relation, that is in the warp space 14 there will be provided two or more sets of warps each set comprising the warp threads of a single fabric. In this last-named case it is only necessary to provide each of the picker slides 38 with an appropriate number of picker fingers 51, so that upon reciprocating the slides 38 in the manner hereinbefore pointed out, such picker fingers may engage with appropriate picker plates to move the shuttles and cause the filling to be laid in two or more fabrics, according to the number of fabrics being woven in vertical relation. For instance, in a two-bank double deck batten each of the picker slides 38 will have two picker fingers 51 with their cooperating yielding plungers or followers and in the operation of such construction the upper picker finger of one picker slide will be moving a picker plate

in one direction while the lower picker finger of the opposite picker slide will be moving a picker plate in the opposite direction, that is two rows of shuttles will be moved at the same time to lay the filling in the shed of two separate fabrics.

From the construction hereinbefore described as one embodiment of the present invention, it will be noted that while the motion of the shuttles is positive and not dependent upon flexible connections such as chains, rawhides or catgut, each of the banks or series of shuttles is left free from the actuating means as soon as the shuttles have moved in either direction to lay the filling in the shed, so that should occasion require, the shuttles may be freely moved by hand in either direction while the loom is at rest.

In view of the fact that each bank or series of shuttles when moved in the manner stated, is left free, it is at times desirable to provide some means for preventing accidental or undesired movement of the banks or series of shuttles, and as one means to this end the auxiliary batten 12 has attached to its upper and lower rails a bracket 71, Figs. 1 and 6, preferably midway between the brackets 30, or at a point between the picker slides 38 when said picker slides are in their nearest related positions. The bracket 71 is provided with a series of sockets 72 containing plungers 73 having rounded end portions 74 for engaging suitable depressions or sockets in the picker plates 53 near the end portions thereof, as indicated in Fig. 6. These plungers are normally acted upon by the springs 75, Fig. 6, the construction being such that when one of the picker plates is moved to the limit of its stroke in either direction, one of the plungers will engage the depressions or socketed portion in the end of the plate, as indicated in Fig. 6, and yieldingly maintain the picker plate in the position to which it has been moved and where it is left by the picker finger. Obviously various forms of means might be provided for preventing this accidental movement of the picker plates, and it is to be understood that the invention is not limited in this respect, although the form shown and described is found to be of convenient construction.

In order to effect the movement of the picker slides 38 toward and from each other in the manner hereinbefore noted, the present invention contemplates the actuation of the picker levers by positive connection with the under-shaft of the loom, or with the crank-shaft. To this end the batten 8 has secured to and projecting downward therefrom, a bracket 76, Figs. 1 and 2, the lower portion of said bracket 76 having a bearing 77 for a crank-shaft

78, said crank-shaft being held from longitudinal movement in the said bearing 77 and therefore partaking of the to and fro movement of the lay or batten 8. Projecting from the crank-shaft 78 is a crank arm 79 having a slot or guideway 80 in which is located a crank pin slide carrying a crank pin 81, Fig. 1, said crank pin 81 being adjustable lengthwise of the crank 79 by means of an adjusting screw 82 threaded through the said crank pin slide and having its other end provided with collars 83 to engage between them suitable lugs 84 projecting from the crank arm, the construction being such that upon manipulation of the adjusting screw 82 the crank pin 81 may be moved to or from the end of the crank arm.

Connected to the crank pin 81 is the adjustable pitman 85, said pitman being preferably formed of two parts, as indicated in Fig. 1, and having a right and left screw connection as at 86 whereby the length of said pitman may be varied. Said pitman is connected at 87 to the lower arm of the picker lever 40, the construction being such that upon rotation of the crank-shaft the picker levers will be operated to move the picker slides toward and from each other in the manner hereinbefore explained.

Secured to the under-shaft 88, is a bevel gear 89, Figs. 1 and 3, which meshes with a corresponding bevel gear 90 splined to the shaft 91 as will be clear from Figs. 2 and 3. The shaft 91 is connected to the crank-shaft 78 by a universal joint 92, the construction being such that as the lay or batten 8 moves toward the front and rear of the loom, the shaft 91 will slide lengthwise through the bevel gear 90 and the universal joint 92 will act to prevent any binding and facilitate ease of rotary motion of the crank shaft. In order that the rise and fall of the batten or lay 8 may find compensation in the connection of the crank with the under-shaft, the under-shaft 88 has mounted thereon a loose sleeve 93 (Fig. 3) connected by a web 94 with a similar sleeve 95 on the shaft 91, the construction being such that as the batten or lay 8 rises and falls in its arc of movement toward and from the front of the loom, the connected rocking sleeves 93 and 95 will rock about the axis of the under-shaft 88 and thus compensate for this rising and falling movement of the lay.

While the present invention has been illustrative in connection with a particular type of narrow ware loom, it is to be understood that it is a general application and not restricted thereto; indeed, this appears to be the first case in the art wherein a batten or series of shuttles of a narrow ware loom are given positive movement from an actuating means and then left free to be moved by hand, if desired. The present invention is also generic with respect to the

picker fingers and their characteristic operation in connection with the picker plates, and while these parts have been illustrated and described as comprising certain constructions, it is to be understood that the invention in its true scope is defined by the claims, and not necessarily restricted to the details shown and described.

What is claimed is:—

1. In a narrow ware loom shuttle motion, the combination of picker slides, picker fingers carried by said slides, means for simultaneously moving the slides toward and from each other, a shuttle actuating rack, and means for causing said picker fingers to be alternately engaged with said rack to move the shuttles first in one and then the opposite direction.

2. In a narrow ware loom shuttle motion, the combination of two picker slides each carrying a picker finger, a shuttle actuating picker plate, means for simultaneously moving said slides toward and from each other, and means for causing one of said picker fingers to engage the picker plate to move the shuttles in one direction and the other of said picker fingers to engage said plate to move the shuttles in the opposite direction.

3. In a narrow ware loom shuttle motion, a picker plate, operative connections between it and a bank or series of shuttles, picker fingers normally disconnected from said plate, means for moving the picker fingers simultaneously in opposite directions, and means for causing one of said picker fingers to engage and move the picker plate in one direction and the other picker finger to engage and move the picker plate in the opposite direction.

4. In a narrow ware loom shuttle motion, a picker plate, operative connections between it and a bank or series of shuttles, picker fingers normally disconnected from said plate, means for moving the picker fingers simultaneously in opposite directions, means for causing one of said picker fingers to engage and move the picker plate in one direction and the other picker finger to engage and move the picker plate in the opposite direction, and means to obstruct movement of said plate when not engaged by either picker finger.

5. In a narrow ware loom shuttle motion, operative connections between said plate and moving them rectilinearly, a picker plate, a bank or series of shuttles, and means for causing said picker fingers to separately engage and move said picker plate at different times and then become disengaged therefrom leaving the bank or series of shuttles free to be moved manually.

6. In a narrow ware loom shuttle motion, the combination of actuating means connected to a bank or series of shuttles, driv-

- ing devices for said means normally disconnected therefrom, means for simultaneously operating said driving devices in opposite directions, and means for causing the driving devices to engage and actuate the actuating means only when the bank or series of shuttles connected thereto is to be moved.
7. In a shuttle motion for narrow ware looms, the combination of actuating means connected to a bank or series of shuttles, a driver for said actuating means, operating devices for reciprocating the driver in a path normally of non-engagement with the actuating means, and means for causing a part of the driver to be projected from its normal path into a path for engaging said actuating means when a bank or series of shuttles is to be moved.
8. In a narrow ware loom shuttle motion, the combination of a lay or batten, actuating means connected to a bank or series of shuttles, movable with said lay or batten, reciprocating driving devices for said means normally disconnected therefrom, means for causing a part of the driving devices to be moved relative to its path of reciprocation to engage and actuate the actuating means only when the bank or series of shuttles connected thereto is to be moved, and means for holding said bank or series of shuttles from accidental movement when said actuating means is disengaged from said driving devices.
9. In a narrow ware loom shuttle motion, the combination of picker fingers, means to move said picker fingers in rectilinear paths toward and from each other, a plurality of picker plates each operatively connected to a bank or series of shuttles and movable to position any one of said plates adjacent the path of the picker fingers, and means to move a picker finger relative to its path of reciprocation to engage and move the picker plate that is adjacent its path of movement and then disengage the same.
10. In a narrow ware loom shuttle motion, the combination of means connected to and for actuating a series or bank of shuttles, driving devices for said means normally disconnected therefrom and movable in rectilinear paths toward and from each other, adjusting devices to vary the paths of movement of said driving devices, and means for causing the driving devices to engage and actuate the shuttle actuating means first in one and then in the opposite direction.
11. In a narrow ware loom shuttle motion, the combination of picker fingers, means to move said picker fingers in rectilinear paths toward and from each other, means for varying the amplitude of movement of said picker fingers, a plurality of picker plates each operatively connected to a bank or series of shuttles and movable to position any one of said plates adjacent the path of the picker fingers, and means to cause a picker finger to engage and move the picker plate that is adjacent its path of movement and then disengage the same.
12. In a narrow ware loom, the combination of picker fingers, means for moving said picker fingers simultaneously in rectilinear paths toward and from each other, a plurality of picker plates, each operatively connected to a separate bank or series of shuttles, means for causing a picker finger to engage and move the picker plate adjacent its path of movement in one direction and another picker finger to engage and move the picker plate in the opposite direction.
13. In a narrow ware loom, the combination of a lay or batten, guiding means extending longitudinally of the lay or batten, picker slides guided by said means, picker fingers carried by said slides, means for simultaneously moving said slides toward and from each other, a picker plate connected to a bank or series of shuttles and means for causing a picker finger to engage and move a picker plate.
14. In a narrow ware loom, the combination of a lay or batten, guiding means carried thereby, picker slides guided by said means, picker fingers carried by said picker slides, means for moving said slides toward and from each other, a device connected to and for actuating a bank or series of shuttles, and means acting upon the picker fingers to move them on their respective slides and cause one or the other to engage said device.
15. In a narrow ware loom, the combination of a lay or batten, guiding means carried thereby, picker slides guided by said means, picker fingers carried by said picker slides, means for simultaneously moving said slides toward and from each other, a device connected to and for actuating a bank or series of shuttles, a yielding follower to engage and position said fingers as the slides are separated to cause one or the other of said fingers to meet and move said device as the slides are moved toward each other.
16. In a narrow ware loom, the combination of two picker slides each carrying a picker finger pivotally mounted thereon, means for moving said slides toward and from each other, a yielding follower acting on each picker finger as the slides are separated to turn the fingers, and a device connected to a bank or series of shuttles adapted to be engaged by one of said fingers as the slides move toward each other for operating the shuttles.
17. In a narrow ware loom, the combination of picker slides each carrying a picker finger having a notched or engaging end portion and a tail piece, means for simultaneously moving the slides toward and from

each other, a device connected to a bank or series of shuttles, a yielding follower adapted to act upon the tail piece of the picker finger as it is moved by the slide and to follow the finger and maintain it in position until it has engaged the said device.

18. In a narrow ware loom having a plurality of banks of shuttles, the combination of two slides, positive means for moving said slides toward and from each other, pivoted fingers carried by said slides, a picker plate connected to each bank of shuttles and movable to and from a position adjacent the path of movement of said pivoted fingers, means acting normally to hold said fingers from engagement with the picker plates, and means acting to move said fingers into position to engage a picker plate when the same is in position adjacent the path of movement of said fingers.

19. In a narrow ware loom, the combination of a lay or batten, two picker levers pivotally mounted thereon, two slides one connected to each of said levers, and carrying picker fingers, a crank shaft, positive connections between the crank shaft and said levers for moving them to carry the slides toward and from each other, and driving connections for said crank shaft.

20. In a narrow ware loom, a lay or batten, means for operating the same, slides mounted upon the lay or batten and movable toward and from each other, picker fingers carried by said slides, picker levers con-

nected to said slides, a crank shaft movable with the lay and connected to said levers, and means for operating the crank shaft.

21. In a narrow ware loom, the combination of a lay or batten, picker slides each carrying a picker finger and mounted on said lay or batten, devices connected to a bank or series of shuttles and adapted to be periodically engaged by one of said picker fingers for moving the shuttles in one direction and by the other of said fingers for moving the shuttles in the opposite direction, a crank shaft movable with the lay, a gear splined to said shaft, and means for actuating said gear.

22. In a narrow ware loom, the combination of a lay or batten, picker slides each carrying a picker finger and mounted on said lay or batten, devices connected to a bank or series of shuttles and adapted to be periodically engaged by one of said picker fingers for moving the shuttles in one direction and by the other of said fingers for moving the shuttles in the opposite direction, a crank shaft movable with the lay and having a universal joint in its length.

In testimony whereof, I have signed my name to this specification, in the presence of two subscribing witnesses.

ARTHUR EMERY.

Witnesses:

ELIZABETH R. LEVAN,
RETTA M. BECK.

Certificate of Correction.

It is hereby certified that in Letters Patent No. 1,057,133, granted March 25, 1913, upon the application of Arthur Emery, of Philadelphia, Pennsylvania, for an improvement in "Narrow-Ware Looms," an error appears in the printed specification requiring correction as follows: Page 5, lines 120 and 121, claim 5, strike out the words and comma "operative connections between said plate and moving them rectilinearly, a picker plate," and insert instead *the combination of picker fingers, means for moving them rectilinearly, a picker plate, operative connections between said plate and*; and that the said Letters Patent should be read with this correction therein that the same may conform to the record of the case in the Patent Office.

Signed and sealed this 13th day of March, A. D., 1923.

[SEAL.]

KARL FENNING,
Acting Commissioner of Patents.

each other, a device connected to a bank or series of shuttles, a yielding follower adapted to act upon the tail piece of the picker finger as it is moved by the slide and to follow the finger and maintain it in position until it has engaged the said device.

18. In a narrow ware loom having a plurality of banks of shuttles, the combination of two slides, positive means for moving said slides toward and from each other, pivoted fingers carried by said slides, a picker plate connected to each bank of shuttles and movable to and from a position adjacent the path of movement of said pivoted fingers, means acting normally to hold said fingers from engagement with the picker plates, and means acting to move said fingers into position to engage a picker plate when the same is in position adjacent the path of movement of said fingers.

19. In a narrow ware loom, the combination of a lay or batten, two picker levers pivotally mounted thereon, two slides one connected to each of said levers, and carrying picker fingers, a crank shaft, positive connections between the crank shaft and said levers for moving them to carry the slides toward and from each other, and driving connections for said crank shaft.

20. In a narrow ware loom, a lay or batten, means for operating the same, slides mounted upon the lay or batten and movable toward and from each other, picker fingers carried by said slides, picker levers con-

nected to said slides, a crank shaft movable with the lay and connected to said levers, and means for operating the crank shaft.

21. In a narrow ware loom, the combination of a lay or batten, picker slides each carrying a picker finger and mounted on said lay or batten, devices connected to a bank or series of shuttles and adapted to be periodically engaged by one of said picker fingers for moving the shuttles in one direction and by the other of said fingers for moving the shuttles in the opposite direction, a crank shaft movable with the lay, a gear splined to said shaft, and means for actuating said gear.

22. In a narrow ware loom, the combination of a lay or batten, picker slides each carrying a picker finger and mounted on said lay or batten, devices connected to a bank or series of shuttles and adapted to be periodically engaged by one of said picker fingers for moving the shuttles in one direction and by the other of said fingers for moving the shuttles in the opposite direction, a crank shaft movable with the lay and having a universal joint in its length.

In testimony whereof, I have signed my name to this specification, in the presence of two subscribing witnesses.

ARTHUR EMERY.

Witnesses:

ELIZABETH R. LEVAN,
RETTA M. BECK.

Certificate of Correction.

It is hereby certified that in Letters Patent No. 1,057,133, granted March 25, 1913, upon the application of Arthur Emery, of Philadelphia, Pennsylvania, for an improvement in "Narrow-Ware Looms," an error appears in the printed specification requiring correction as follows: Page 5, lines 120 and 121, claim 5, strike out the words and comma "operative connections between said plate and moving them rectilinearly, a picker plate," and insert instead *the combination of picker fingers, means for moving them rectilinearly, a picker plate, operative connections between said plate and*; and that the said Letters Patent should be read with this correction therein that the same may conform to the record of the case in the Patent Office.

Signed and sealed this 13th day of March, A. D., 1923.

[SEAL.]

KARL FENNING,
Acting Commissioner of Patents.

Certificate of Correction.

It is hereby certified that in Letters Patent No. 1,057,133, granted March 25, 1913, upon the application of Arthur Emery, of Philadelphia, Pennsylvania, for an improvement in "Narrow-Ware Looms," an error appears in the printed specification requiring correction as follows: Page 5, lines 120 and 121, claim 5, strike out the words and comma "operative connections between said plate and moving them rectilinearly, a picker plate," and insert instead *the combination of picker fingers, means for moving them rectilinearly, a picker plate, operative connections between said plate and*; and that the said Letters Patent should be read with this correction therein that the same may conform to the record of the case in the Patent Office.

Signed and sealed this 13th day of March, A. D., 1923.

[SEAL.]

KARL FENNING,
Acting Commissioner of Patents.