

No. 714,909.

Patented Dec. 2, 1902.

G. F. HUTCHINS & E. H. RYON.

LOOM.

(Application filed Jan. 16, 1902.)

(No Model.)

6 Sheets—Sheet 1.

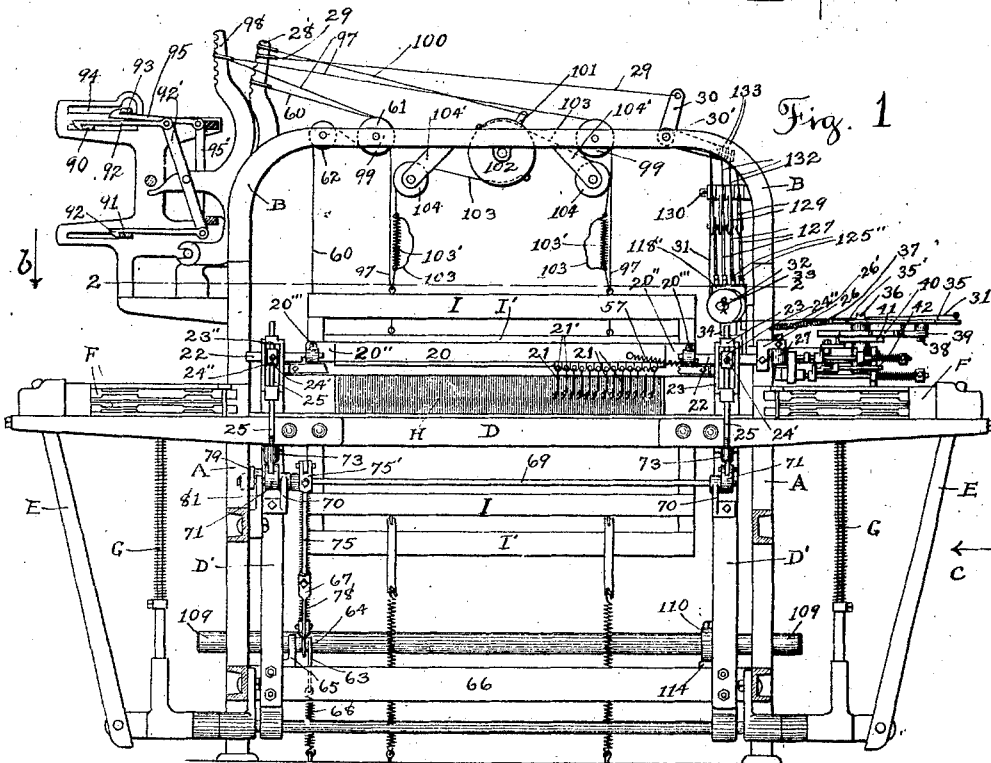
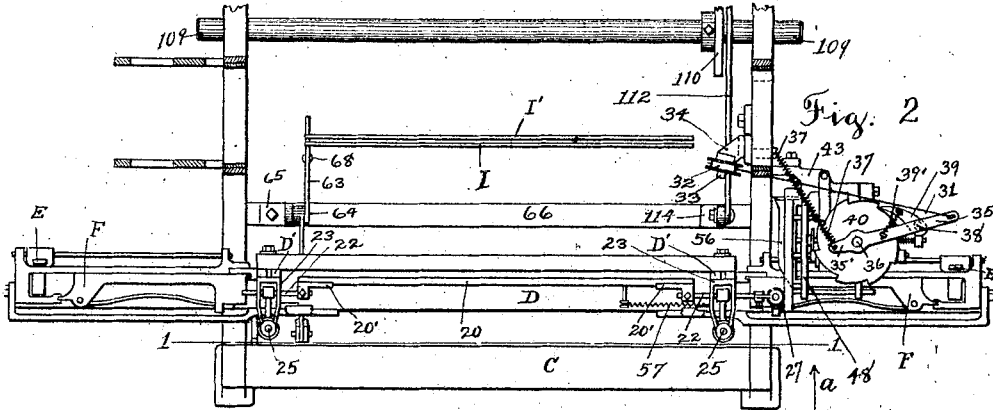

Witnesses  
 S. A. Kinsley  
 M. Head

Inventors  
 George F. Hutchins  
 & E. H. Ryon  
 By John C. Dewey Atty

G. F. HUTCHINS & E. H. RYON.

LOOM.

(Application filed Jan. 16, 1902.)

6 Sheets—Sheet 2.

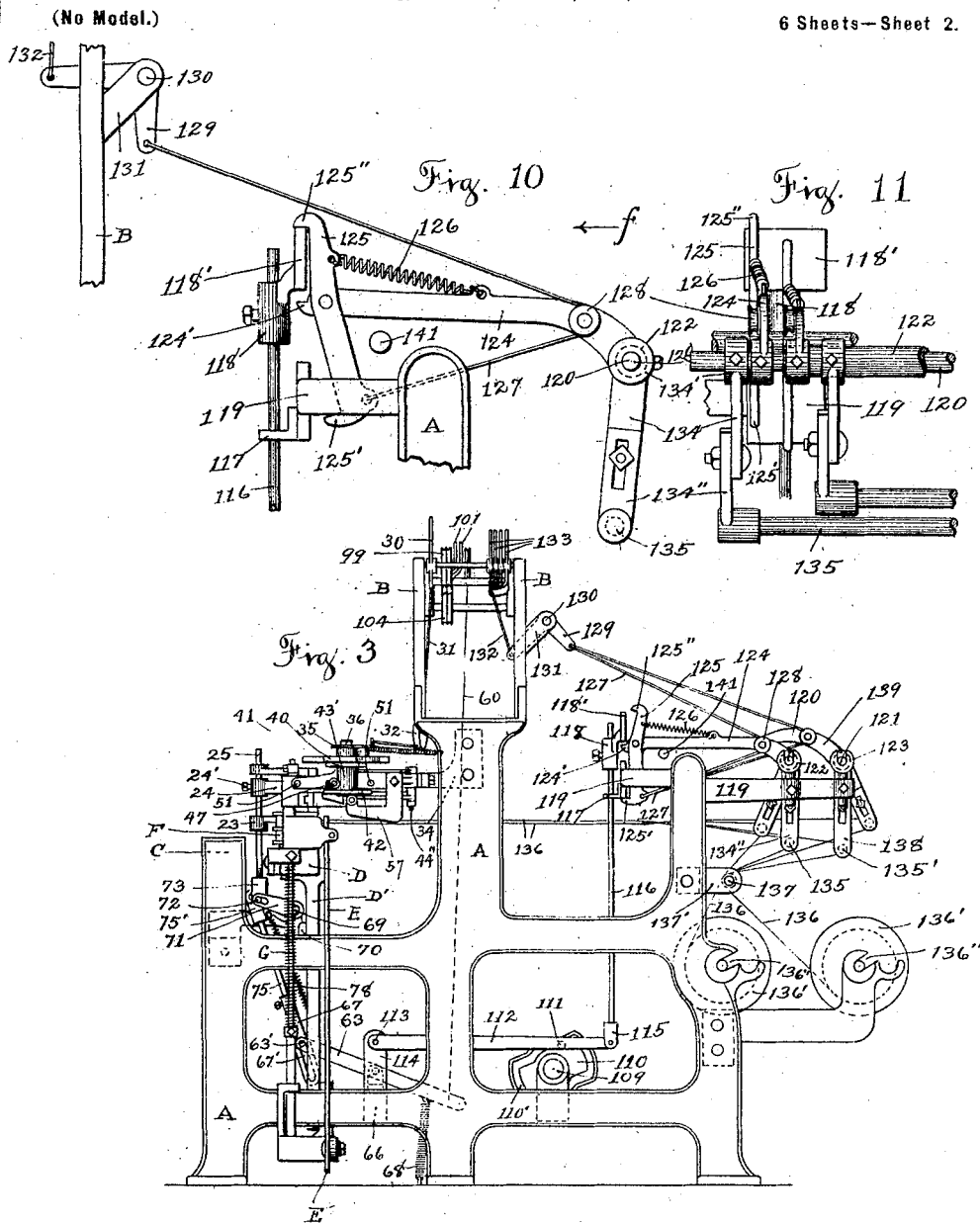

Witnesses  
 S. A. Kinsley  
 M. Heavey

Inventors  
 George F. Hutchins  
 Eppa H. Ryon  
 John C. Dewey, Atty

G. F. HUTCHINS & E. H. RYON.

LOOM.

(Application filed Jan. 16, 1902.)

(No Model.)

6 Sheets—Sheet 3.

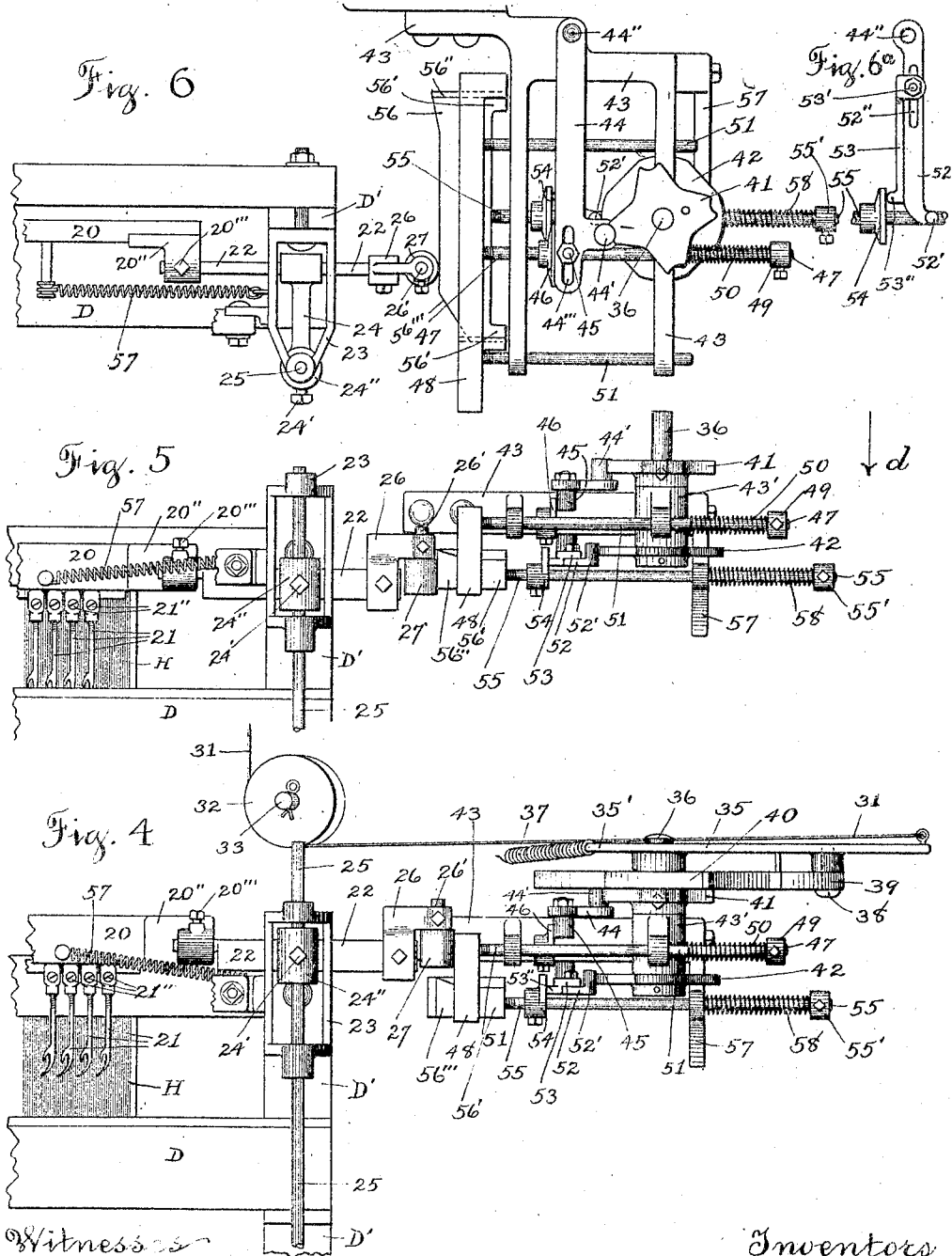

Witnesses  
*J. A. Kinney*  
*M. Heas*

Inventors  
*George F. Hutchins*  
*Eppa H. Ryon*

*By John C. Dewey Atty*

G. F. HUTCHINS & E. H. RYON.  
LOOM.

(Application filed Jan. 16, 1902.)

6 Sheets—Sheet 4.

(No Model.)

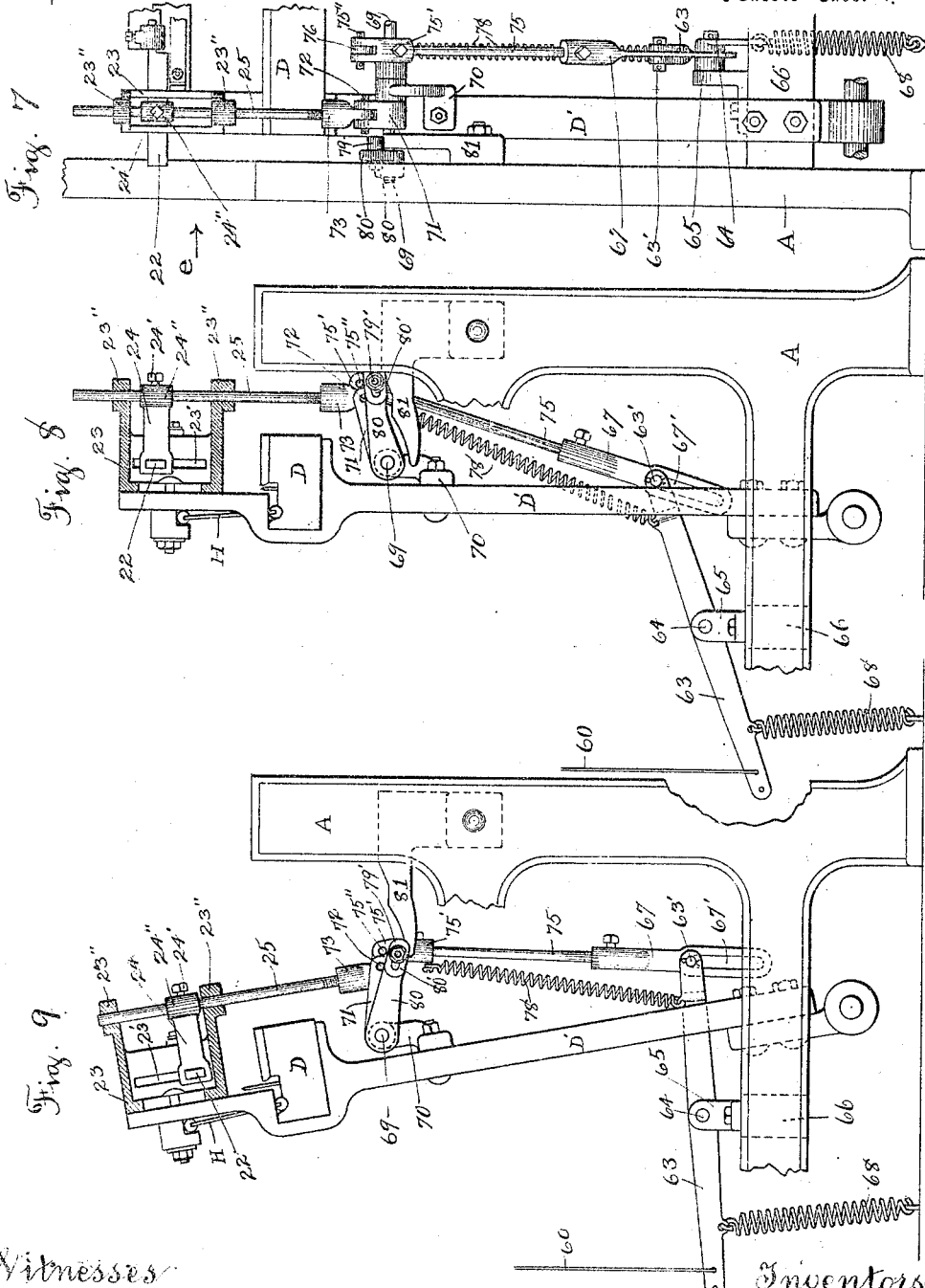

Witnesses  
J. A. Kinsley  
W. Flood

Inventors:  
George F. Hutchins  
Eppa H. Ryon  
By John C. Dewey Atty

No. 714,909.

Patented Dec. 2, 1902.

G. F. HUTCHINS & E. H. RYON.

LOOM.

(Application filed Jan. 16, 1902.)

(No Model.)

6 Sheets—Sheet 5.

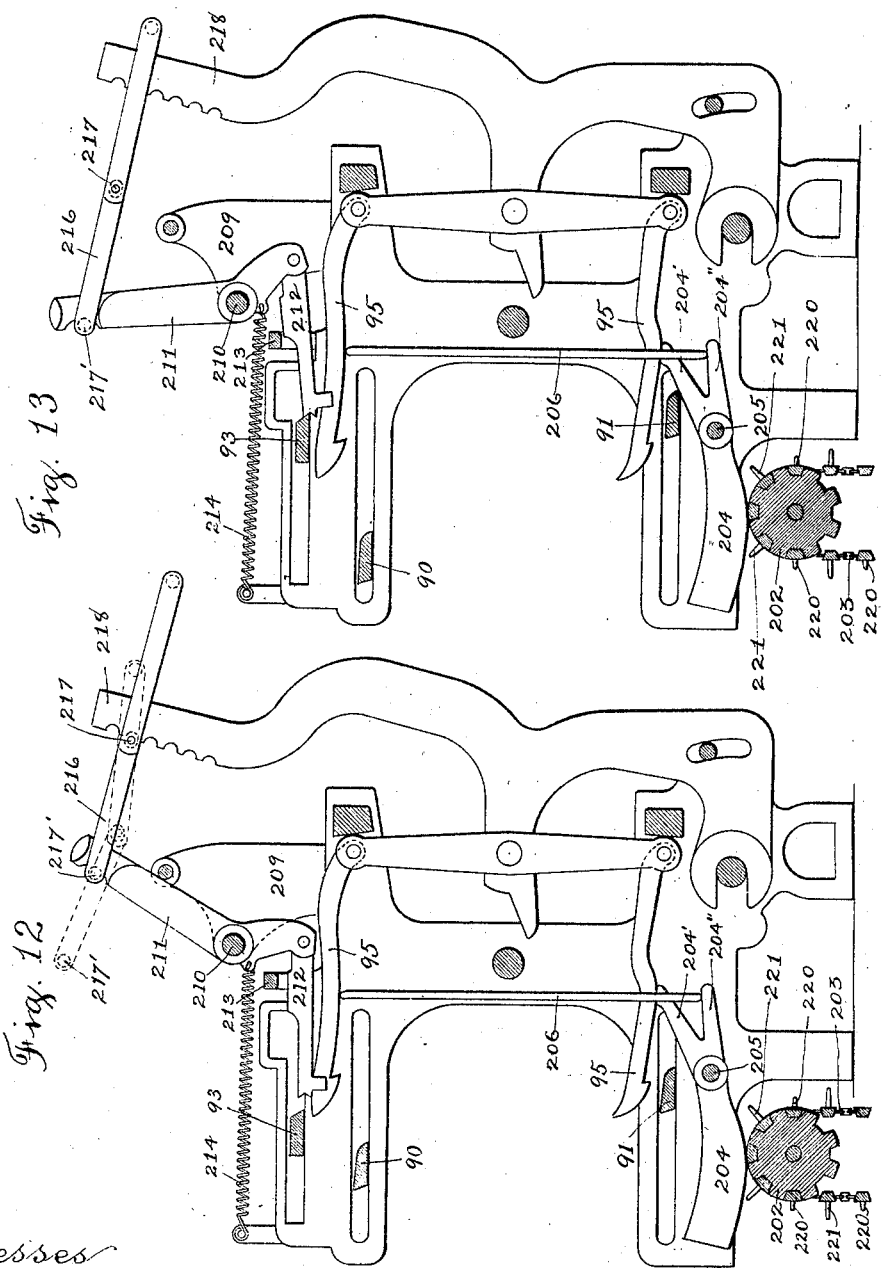

Fig. 13

Fig. 12

Witnesses  
*J. A. Kinley*  
*W. Haas*

Inventors  
*George F. Hutchins*  
*Eppa H. Ryon*  
 By *John C. Dewey* Atty

No. 714,909.

Patented Dec. 2, 1902

G. F. HUTCHINS & E. H. RYON.

LOOM.

(Application filed Jan. 16, 1902.)

(No Model.)

6 Sheets—Sheet 6.

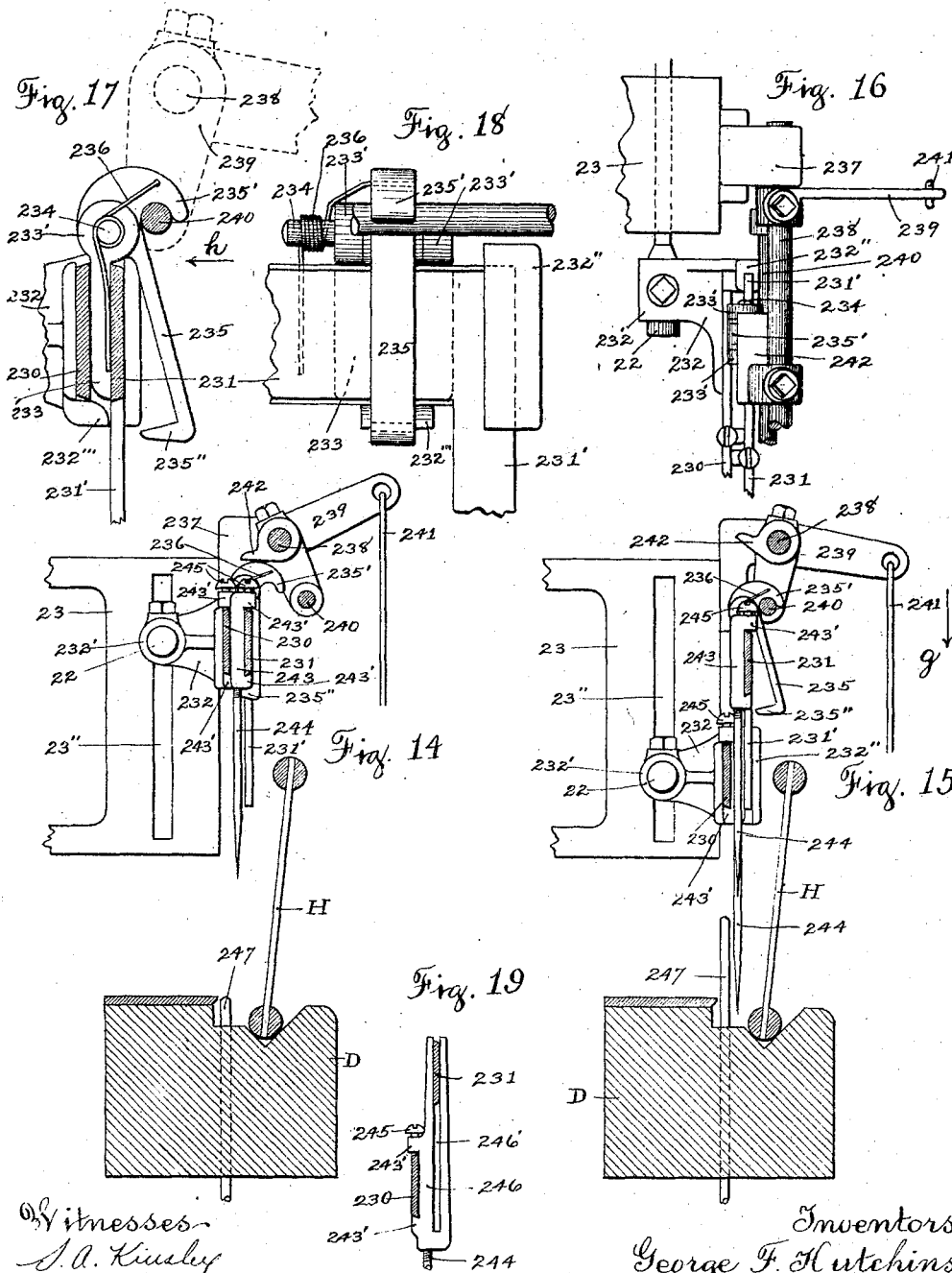

Witnesses  
J. A. Kinley  
M. Heas

Inventors  
George F. Hutchins  
Eppa H. Ryon

By

John C. Dewey Atty

# UNITED STATES PATENT OFFICE.

GEORGE F. HUTCHINS AND EPPA H. RYON, OF WORCESTER, MASSACHUSETTS, ASSIGNORS TO CROMPTON & KNOWLES LOOM WORKS, OF WORCESTER, MASSACHUSETTS, A CORPORATION OF MASSACHUSETTS.

## LOOM.

Application forming part of Letters Patent No. 714,909, dated December 2, 1902.

Application filed January 16, 1902. Serial No. 89,990. (No model.)

*To all whom it may concern:*

Be it known that we, GEORGE F. HUTCHINS and EPPA H. RYON, citizens of the United States, residing at Worcester, in the county of Worcester and State of Massachusetts, have jointly invented certain new and useful Improvements in Looms, of which the following is a specification.

Our invention relates to power-loom, and more particularly to automatic cross-weave mechanism for power-loom; and the object of our invention is to provide automatic cross-weave mechanism for power-loom by means of which certain novel effects in weaving can be produced on power-loom which have heretofore been produced on hand-loom.

In our automatic cross-weave mechanism certain warp-threads are taken while the shed is forming by needles which extend directly in front of the reed and have forked or two-pronged ends and carried across in groups simultaneously over adjacent groups of warp-threads and then carried down between the warp-threads to form the bottom of the shed, while the remaining warp-threads are raised to form the top of the shed. In certain patterns all the warp-threads would be used, some in crossing over and forming the bottom shed and the others in making the top of the shed; but this is not necessary. We can use a limited number of warp-threads in the cross-weave, and the rest of the warp-threads can be used in weaving the fabric in the ordinary way.

Our invention consists in certain novel features of construction of our improvements, as will be hereinafter fully described.

Referring to the drawings, Figure 1 is a sectional front view of a loom embodying our improvements, the section being taken through the frame at a point indicated by line 1 1, Fig. 2, looking in the direction of arrow *a*, same figure. Fig. 2 is a sectional plan view of the parts shown in Fig. 1, the section being taken at a point indicated by line 2 2, Fig. 1, looking in the direction of arrow *b*, same figure. Fig. 3 is an end view of the parts shown in Fig. 1 looking in the direction of arrow *c*, same figure. Fig. 4 shows

on an enlarged scale some of the parts which are shown at the right in Fig. 1. Fig. 5 corresponds to Fig. 4, but shows the parts in another position. Fig. 6 is a plan view of the parts shown in Fig. 5 looking in the direction of arrow *d*, same figure. Fig. 6<sup>a</sup> shows certain parts shown in Fig. 6 detached. Fig. 7 shows on an enlarged scale some of the parts detached which are shown at the left in Fig. 1. Fig. 8 is a side view of the parts shown in Fig. 7 looking in the direction of arrow *e*, same figure. Fig. 9 corresponds to Fig. 8, but shows the parts in a different position. Fig. 10 shows on an enlarged scale some of the parts detached shown at the right in Fig. 3. Fig. 11 shows an end view of some of the parts shown in Fig. 10 looking in the direction of arrow *f*, same figure. Some additional parts are shown in this figure. Fig. 12 shows on an enlarged scale a modified construction of the dobbie mechanism shown at the left in Fig. 1. Fig. 13 corresponds to Fig. 12, but shows the parts in a different position. Fig. 14 shows a sectional view of the lay and of a modified construction of the needle-bar. Fig. 15 corresponds to Fig. 14, but shows some of the parts in a different position. Fig. 16 is a plan view of the parts shown in Fig. 15 looking in the direction of arrow *g*, same figure. Fig. 17 shows on an enlarged scale some of the parts shown in Fig. 15 detached. Fig. 18 is a side view of the parts shown in Fig. 17 looking in the direction of arrow *h*, same figure; and Fig. 19 is a sectional view through the needle-bars, showing a modified construction of the needle-holder.

In the accompanying drawings, A represents the loom sides or frames; B, the arches; C, the breast-beam; D, the lay, mounted on the lay-swords D'; E, the picker-sticks; F, the movable shuttle-boxes—in this instance two on each end of the loom, mounted on the box-lifters G; H, the reed, and I I' the harnesses.

We will now describe our improvements applied to the parts of the loom above described, and first the needle mechanism.

A needle-bar 20 carries in this instance a series of downwardly-extending needles 21, 10

which may be adjustably attached at their upper ends to the lower part of the needle-bar 20 by screws 21' or otherwise, and the lower engaging ends of the needles are made  
 5 forked or with two prongs, (see Fig. 4)—that is, with open eyes for the free entrance of the warp-threads which are to be transferred instead of with closed eyes through which the  
 10 warp-threads are threaded, as is customary in lappet and other similar looms. The needle-bar 20 has in this instance at each end a bracket 20'' thereon and a set-screw 20''', by means of which the needle-bar 20 is secured  
 15 at each end to the end of the two horizontal sliding bars 22; which pass through and are guided in vertical slots 23' in the guides 23, fast to the upper ends of the lay-swords D' at each end of the loom, as shown in Figs. 8 and 9. The bars 22 extend through a slot in  
 20 one end of an arm 24 and have a vertical motion with said arm, which is attached by a set-screw 24' on a vertically-moving rod 25, which passes through a hub 24'' on said arm 24. On the outer end of one of the bars 22—in this  
 25 instance on the right-hand end of the loom, (shown in Fig. 1)—is fast an angle-iron 26, carrying a stud 26', on which is mounted a roll 27. The roll 27 bears on a cam-surface, (see Fig. 6,) which controls the transverse  
 30 motion given to the needle-bar 20, carrying the needles 21, which needles engage the warp-threads and carry them across the adjacent warp-threads.

We will now describe the mechanism for  
 35 producing the transverse motion of the needle-bar and needles, as desired.

A jack 28 (see Fig. 1) has one end of a connector 29 attached thereto and the other end of said connector attached to one arm of the  
 40 bell-crank lever 30, pivoted at 30' on the loom-arches B. The other arm of the bell-crank lever 30 is attached to one end of a connector 31, which passes under a roll 32, mounted on a stud 33 on a stand 34, secured to the loom  
 45 side. The other end of said connector 31 is attached to the outer end of a horizontal lever 35, loosely mounted on a shaft 36. (See Figs. 2 and 4.) To an extension 35' on the  
 50 inner end of the lever 35 is fast one end of a spiral-spring 37. The other end of said spring 37 is fast to the loom side. The lever 35 has thereon a stud 38, on which is pivoted a pawl 39 for actuating the ratchet 40 and held in  
 55 engagement therewith by a spring 39', attached to the pawl 39 and to the lever 35. (See Fig. 2.) The ratchet 40 is fast on the vertical shaft 36. Extending under the ratchet 40 and also fast on the shaft 36 is a cam 41 and a second cam 42. (See Figs. 4, 5, and 6.)  
 60 The shaft 36 has its bearing in a hub 43' on the stand 43.

It will be seen that when the jack 28 is raised the ratchet 40 will be turned one tooth by the pawl 39 through intermediate connections,  
 65 by the pawl 39 through intermediate connections, and the cams 41 and 42, both fast on the shaft 36, will be rotated similarly—in this instance one-eighth of a revolution. The pe-

riphery of one cam 41 (see Figs. 4, 5, and 6) bears on the rounded extension 44' on the lever 44, pivoted at 44'' on the stand 43. (See  
 70 Fig. 6.) The lever 44 has the slot 44''' in its free end, in which is supported to extend downwardly, as shown in Figs. 4 and 5, a stud 45, which bears on a flange or disk 46, fast on a rod 47. The inner end of the rod 47 is se-  
 75 cured to a guide-plate 48, and the other end of the rod 47 extends through an arm of the stand 43 and has a collar 49' fast on its end, between which and the stand 43 extends an  
 80 expansion-spring 50, mounted on the rod 47, which spring acts to hold the flange or disk 46 in contact with the stud 45 and the rounded extension 44' in contact with the periphery of the cam 41. The guide-plate 48 has secured thereto near each end the inner ends of two  
 85 guide-rods 51, which pass through the arms on the stand 43. Said rods 51 hold and guide the plate 48 as it is moved toward the lay through the cam 41, lever 44, and roll 45, engaging the flange or disk 46 on the rod 47, se-  
 90 cured to said plate 48 and moved away from the lay by the spring 50. The periphery of the cam 42, which extends below the cam 41 and is fast on the shaft 36, bears against the rounded extension 52' on the lever 52, pivotally  
 95 mounted on the stud 44'' in the stand 43. The lever 52 has a slot 52' (see Fig. 6<sup>a</sup>) for adjustment of the engaging bar 53, secured to the lever 52 by a bolt 53'. The bar 53 has a rounded extension 53'', which bears against  
 100 the flange or disk 54, fast on the rod 55, which rod has attached to its inner end the cam-plate 56. The rod 55 has bearings in a bracket 57, secured to the stand 43, and has an expansion-spring 58 thereon, confined between  
 105 the collar 55' and the bracket 57. (See Fig. 4.) The cam-plate 56 has extensions 56' at each end with ribs or fins 56'' thereon, which extend into and move in grooves in extensions on the guide-plate 48. (See Fig. 6.) The  
 110 guide-plate 48 and the cam-plate 56 have independent horizontal motions governed by the shape of their respective actuating-cams 41 and 42.

The operation of the mechanism above de-  
 115 scribed is as follows: When the lay begins to move forward, the roll 27 travels on the edge or bearing-surface of the guide-plate 48 (see Fig. 4) until it reaches the position shown in Fig. 2. Then the lay begins the return stroke,  
 120 and the shed opens. The vertically-moving rods 25, controlling the vertical movement of the needle-bar 20 and the needles 21 through intermediate mechanism to be hereinafter described, will have a downward movement.  
 125 The roll 27 is also carried downward, so that on the backward stroke of the lay said roll 27 will engage and travel on the inclined surface 56''' on the cam 56, thereby causing the  
 130 needle-bar 20 and the needles 21 to move transversely to the left in Fig. 1 against the action of spring 57, secured at one end to the needle-bar 20 and at its other end to the guide 23. This transverse motion of the needle-



bar 20 will be repeated whenever an indication is made to lower the needles into the warp. When it is desired to change the position of the needle-bar 20 previous to entering the warp for the purpose of causing the needles 21 to engage a different set of warp-threads, the cam 41 through jack 28 and intermediate mechanism is given a partial revolution, and the guide-plate 48 assumes a new position through the operation of parts above described. When an indication is next made for carrying the needles downward into the warp, the crossover motion will operate as before, but with the needles engaging a different series of warp-threads. The cam 42, rotating on the same shaft and at the same time as cam 41, controls the position of the cam 56 relative to the guide-plate 48, and therefore determines the amount of travel of the needle-bar 20 transversely to the warp-threads. By virtue of the slot 44" in the lever 44 and the slot 52" in the lever 52, pivoted on stud 44", (see Fig. 6,) adjustment is afforded between the guide-plate 48 and the cam 56. Certain warp-threads, as many as may be required for the pattern to be woven, have been engaged by each of the needles 21 between their respective forked ends, and these warp-threads, held up by the harnesses in the well-known way, are carried out of their normal position by the transverse motion of the needle-bar and across and beyond the corresponding group of adjacent warp-threads. Immediately the needles have gone their distance transversely they are carried downward by mechanism to be hereinafter described, and the warp-threads carried by the needles form the whole or a part of the bottom of the shed. At the same time the adjacent groups of warp-threads not carried down are raised, in the manner to be hereinafter described, to form the whole or part of the upper shed, according to the number of needles and the nature of the pattern.

We will now describe the mechanism for carrying the needle-bar 20 and needles 21 downward into the warp after they have been moved transversely, as above described.

One end of a connector 60 is attached to a jack 28 and passes over the rolls 61 and 62, mounted between the loom-arches. The other end of said connector 60 is attached to one end of a centrally-pivoted lever 63. (See Figs. 3, 7, 8, and 9.) The lever 63 is pivoted on a stud 64 on a stand 65, fast on a cross-girth 66. On the opposite end of the lever 63 is fast a pin 63', which extends into a slot 67' in the lower end of an upright rod 67, where it is held in the position shown in Fig. 9 by a tension-spring 68, connected at one end to the lever 63 and at its other end to the floor, as shown in Fig. 9. A rock-shaft 69 is mounted in bearings 70, secured to the lay-swords, and has fast thereon the rocker-arm 71, in the outer forked end of which extend the ends of the pin 72, free to move in a horizontal slot in the lower end of the collar 73 on the lower

end of the vertically-moving rod 25, which extends through and has bearings 23' in the guides 23. (See Fig. 7.) The supporting-arms 24 of the needle-rod bars 22 are fast on the rods 25. In its normal position the needle-bar 20 is held up by the action of the spring 68. When it is desired to lower the needle-bar 20 and needles 21, the jack 28, to which the connector 60 is attached, is raised to rock the lever 63, and the pin 63' will have a downward movement in the slot 67' in the bar 67. In the upper end of the bar 67 is secured the lower end of the upright bar 75, and the upper end of said bar 75 has the end 75' thereon pivotally attached by the pin 75" to the arm 76, fast on the rock-shaft 69. When the pin 63' moves downward in the slot 67' in the bar 67, as above stated, the needle-bar 20 and needles 21 by force of gravity, assisted by the spring 78, fast to the lever 63 and to the end 75' on the rod 75, are brought downward until the roll 79 on the stud 79' in the slotted end 80' of the arm 80, fast on the rock-shaft 69, comes in contact with the cam-plate 81, secured to the inner side of the loom side. On the forward stroke of the lay the roll 79 travels on cam-plate 81, as shown in Fig. 8, and raises the needle-bar 20 and the needles 21, and on the backward stroke of the lay the roll 79, traveling on the cam-plate 81, determines the amount of downward movement of the needle-bar 20 and needles 21. When the jack 28, to which the connector 60 is attached, is dropped, the spring 68 acts to move the lever 63 and through pin 63' raise the bar 67 and rod 75 and through arm 76 rock the shaft 69 and raise the needle-bar 20 and needles 21.

We will now describe the harness-motion forming part of our improvements.

In cross-weaving the crossing over of the warp-threads cannot begin until the shed has opened sufficiently for the needles to engage their respective groups of threads. The adjacent groups which are to form the top of the shed must stay down until the crossing over has taken place and must then be brought up behind the needles which have just crossed over above them. This operation requires time, and it will be seen that certain harness-frames which are engaged at one time in raising certain warp-threads in the ordinary formation and at another time are required to wait the crossing-over process, above described, must have two independent actuating mechanisms.

At the left in Fig. 1 is shown the dobbie-frame and portions of the dobbie mechanism, of ordinary construction, with which our improvements are combined.

In addition to the ordinary knife-bars 90 and 91, which operate the hook-levers 92, pivotally mounted on opposite ends of the lever 92', centrally pivoted on an extension on the jack in the ordinary way, is a third knife-bar 93, having a motion backward and forward (independent of the motion of the knife-bars

90 and 91) in the slot 94 of the dobbie-frame. (See Fig. 1.) The knife-bar 93, which is independently driven by a crank (not shown) on a revolving shaft of the loom, is carried out and back in its slot 94 while the knife-bars 90 and 91 are making their travel in one direction—that is, the knife-bar 93 makes two complete movements out and in while the knife-bars 90 and 91 are making one complete movement. A hook-lever 95, pivoted on the end of a lever 95', pivotally mounted on an extension on a jack, will when raised, as shown in Fig. 1, engage the knife-bar 93 and through the intermediate connections raise a harness-jack in the ordinary and well-known way, except that the raising of the jack is delayed and takes place in half the time ordinarily required.

The harness-frame I, Fig. 1, is one of the frames requiring two independent motions. Connectors 97 are attached at one end to a jack 98, connected with the dobbie mechanism, and pass over rolls 99 and are connected at their other ends to the upper part of the harness-frame I to raise said frame in the ordinary way. One end of another connector 100 is attached at one end to another jack and at its other end to an offset spoke 101 on the pulley or sheave 102. To the periphery of the sheave 102 and on opposite sides of the same are fast the ends of the connectors 103, which are guided by flanges on the sheave 102 and pass over grooved pulleys 104, mounted in brackets 104', and thence to the harness-frame I, to which they are secured. Springs 103' are attached to the connectors 103 intermediate the harness-frame I and the pulleys 104, as shown in Fig. 1.

It will be seen that when the harness I is called by the jack 98 in the ordinary way the connectors 103 between the pulleys 104 and the harness-frame I will hang slack, the slack being taken up by the springs 103'. After the crossing-over process above described an indication is made for the raising of the harness I through the movement of the knife-bar 93 and intermediate connections to the harness, during which time the connectors 97 will hang slack. Thus the two independent motions of the harness I required by the nature of the weave are provided for.

It is necessary that the crossover-threads have a slackening or easing motion during the crossover process. We will now describe our easing mechanism, which is shown in Figs. 3, 10, and 11 of the drawings. On the bottom shaft 109, Fig. 3, is fast a cam 110, having a groove 110' in one side thereof, into which extends and travels a roll or pin 111 on a lever 112, pivoted at 113 to a stand 114, secured to the cross-girth 66. The opposite end of the lever 112 has pivotally attached thereto the lower end 115 of a vertically-moving rod 116, which is guided at its upper end in a bracket 117 and has fast thereon a collar 118, carrying a plate 118'. (See Fig. 10.) The cam 110 through the intermediate con-

nections gives an up-and-down motion to the plate 118' at every pick of the loom. Supported in suitable bearings attached to the stands 119 at the rear of the loom are two rock-shafts 120 and 121, having thereon sleeves 122 and 123. Fast to the shaft 120 is the lever 124, having at its free end a notched extension 124', extending under the plate 118'. (See Fig. 10.) A lever 125, centrally pivoted on the end of the lever 124, is notched at each end, as shown at 125' and 125''. A spring 126, attached at one end to the upper part of the lever 125 and at its other end to the lever 124, acts to hold the lever 125 in the position shown in Fig. 3, which is in its normal position when the easing motion is not in use. A connector 127 is attached at one end to the lower part of the lever 125 and passes over a grooved roller 128 on the lever 124 and is connected at its end to one arm of an angle-lever 129, pivoted at 130 in a stand 131. The other arm of said angle-lever 130 is connected through the connector 132 with one arm of an angle-lever 133, (see Fig. 3,) and the other arm of said angle-lever 133 is connected by a connector (not shown) with a jack (not shown) of the dobbie mechanism. It will be seen that the movement of the dobbie-jack through intermediate connections will move the lever 125 against the action of the spring 126 to cause its upper notched end 125' to extend over the plate 118', as shown in Fig. 10, and the raising of the rod 116 and the plate 118' thereon will raise the lever 124 and cause the shaft 120 to rock to ease the warp, as will be hereinafter described. Fast on the shaft 120 is the hub 134' of an arm 134, to which is adjustably attached one end of a plate 134'', the other end of which, of hub shape, is fast to the end of the easing-rod 135. (See Fig. 11.) The warp-threads 136, Fig. 3, pass from one of the two beams 136', mounted to turn in suitable bearings 136'' around the fixed rod 137, supported in stands 137', and over the easing-rod 135 and through the harnesses (not shown) to the fell of the fabric in the usual way. The rocking of the shaft 120, above described, by the raising of the lever 124 causes the easing-rod 135, connected with said shaft, to be carried toward the front of the loom, as shown in Fig. 10, thus producing the desired slack in the warp-threads. The operation of the easing-rod 135' at the lower end of the arm 138, fast on the rod 121, which has a lever 139 fast thereon and a lever to correspond with the lever 125, mounted on the end of said lever 139, is the same as the operation of the easing-rod 135, above described. On each rod 120 and 121 is a sleeve 122 and 123, respectively, with levers corresponding to the levers 124 and 139 and arms corresponding to the arms 134 and 138, as shown in Figs. 3 and 11. The sleeves 122 and 123 are free to rotate on the rods 120 and 121. There are four sets of intermediate connections between the four levers of the easing mechanism and four jacks of the dobbie mech-

anism. The plate 118' on the rod 116, which rises and falls at every pick, rises free unless one of the four levers 125 is called through intermediate connections by its dobbie-jack. 5 On the return or downward motion of the plate 118' the four levers corresponding to lever 125 will be brought down by the engagement of the plate 118' with the notched extremity 124' of the levers corresponding to 10 lever 124, and the lower notches 125' on the levers corresponding to levers 125 will engage the bracket 117, as shown in Fig. 3, to prevent the operation of the easing motion due to the strain on the warp-threads. The stop-rod 141 limits the downward movement of 15 the levers.

We will now describe the modified construction of the dobbie and harness jack mechanism, which modified construction is shown 20 in Figs. 12 and 13 of the drawings. In these figures we have shown the pattern-surface and intermediate connections between the pattern-surface and the hooked levers for operating the same to cause them to be engaged 25 with or disengaged from the knife-bars 90 and 91, which are operated in the usual way. The pattern-barrel 202 carries the pattern-chain 203, made up of links and bars carrying pegs or pins. Extending over the pattern-chain is a 30 series of weighted levers 204, pivoted at 205 and which have the forked branches 204' and 204''. The branch 204' engages the lower hooked lever 95 and the branch 204'' engages the lower end of the upright wire 206, whose upper end 35 engages the upper hooked lever 95. The stand 209 is fast to the dobbie-stand and has bearings thereon for the transverse shaft 210. Loosely mounted on said shaft 210 are the centrally-pivoted levers or supplemental 40 jacks 211, to the lower end of each of which is pivotally attached the inner end of the lever 212. The outer end of said lever 212 is slotted or grooved to ride on the outer end and upper edge of the upper hooked lever 95. 45 The extreme end of the lever 212 is notched to be engaged by the knife-bar 93. A stop-bar 213, forming upper part of comb, prevents the lever 212 from being thrown up out of engagement with the hook-lever 95. A coil- 50 spring 214, attached at one end to the lever 211 below its pivotal support and at its other end to a stationary part of the frame, operates to hold the lever 211 and the lever 212 in the position shown in Fig. 12. The upper 55 end of each lever 211 passes through an elongated slot in a loop 216, which has a pin or stud 217, which engages the upper end of the harness-jack 218, as shown in Fig. 12. To the opposite end of the loop 216 is attached 60 the end of a connector (not shown) to a harness-frame in the ordinary way. When the jack 218 is moved to the left, Fig. 12, the loop 216 is moved to the left, as shown by dotted lines, Fig. 12, without moving the lever 211, the grooved end of said lever preventing the 65 loop from falling off of the lever 211. When the lever 211 is moved by engagement of the

knife-bar 93 with the lever 212, as shown in Fig. 13, the loop 216 is also moved by engagement of the lever 211 with pin 217' in loop 216 70 without moving the jack 218, and through a connector (not shown) the harness-frame connected with said loop is moved. The pattern-chain, as shown in Figs. 12 and 13, operates to hold the hooked levers 95 and the lever 212 75 in three different positions. When there is no indicator-pin under the lever 204, the hooked lever 95 and the lever 212 will occupy the position shown in Fig. 12, with the lever 212 in position to be engaged by the knife-bar 93. 80 When a short indicator-pin 220 comes under the lever 204 to raise it, it will lower through intermediate connections the two hooked levers 95 and the lever 212 to an intermediate or an inoperative position, so that the knife- 85 bars 90 and 92 and the knife-bar 93 will move in and out without engaging either of said hooks 95 or the lever 212. When a long indicator-pin 221 comes under the lever 204, it 90 will raise it to its highest position and through intermediate connections lower the hooked levers 95 sufficiently to permit of engagement with the knife-bars 90 and 91 and also lower the 95 lever 212 to a position out of engagement with its knife-bar 93. The knife-bar 93 is operated when desired, as shown in Figs. 12 and 13, to raise the harness attached to the loop 216 at a higher speed than is obtained with the jack 218, while the beginning of the movement to 100 raise said harness is delayed for the purpose heretofore described with reference to the harness motion shown in Fig. 1.

In Figs. 14 to 19, inclusive, we have shown a modified construction of the needle-bar 20. (Shown in Fig. 1.) In the modified construction 105 instead of having a single needle-bar we have two parallel needle-bars 230 and 231. One needle-bar, as 230, is fast to an angle-iron 232, the same as in Figs. 1, 4, 5, and 6, above described. The angle-iron 232 has a hub-like 110 extension 232', in which is fast a sliding rod or bar 22, corresponding to the bar 22 in Figs. 4, 5, and 6 and extending through and guided in a vertical slot 23'' in a guide-plate 23, Figs. 14 and 15. The angle-iron 232 has the extension 115 232'', Figs. 16 and 18, with an open end slot, in which is free to move up and down the end 231' of the needle-bar 231, which is similarly held and guided in the opposite end of the loom. (Not shown.) A plate 233, Figs. 120 16 and 17, with hub-like extensions 233', is fast to the needle-bar 231. The rod 234 is fast in the hubs 233', and a hub 235' on a latch 235 is loosely mounted on said rod 234. The latch 235 has the two hooked ends 235' and 235'' and is held in its normal position (shown 125 in Fig. 14) by the action of the spring 236, one end of which is secured to the upper end of the latch 235 and the other end bears against the needle-bar 231. (See Fig. 17.) 130 The lower hooked end 235'' of the latch 235 extends under and engages the under side of the offset 232''' on the angle-iron 232, as shown in Fig. 14, so that normally the two needle-

bars 230 and 231 will be carried up and down as one bar, as previously described in connection with the needle-bar 20 in the previous figures. Secured to the guide-plate 23 is a stand 237, having a bearing for the rod 238. Fast on the rod 238 is an angle-lever 239, carrying the rod 240 in one arm and having a connector 241 attached to the other arm, which connector is connected through intermediate connections (not shown) with a dobby-jack. (Not shown.) The raising of the jack when desired acts through intermediate connections and the connector 241 to draw down the arm of the angle-lever 239, to which it is attached, and cause the rod 240 to extend under the hook 235' on the latch 235. (See Fig. 15.) As the two needle-bars 230 and 231 start to move down, operated in the same manner as above described in connection with the needle-bar 20, the engagement of the rod 240 with the hook end 235' of the latch 235, as above described, moves the latch 235 on its pivotal support against the action of the spring 236 and disengages the lower end 235'' from the offset 232''' on the angle-iron 232, leaving the needle-bar 230 free to be lowered, while the needle-bar 231 remains in its raised position, held up by the engagement of the hook 235' of the latch 235 with the rod 240, as shown in Fig. 15. It will be understood that the rods 238 and 240 extend transversely across the loom, and there is a corresponding latch 235 at the opposite end of the loom. (Not shown.) On the return movement of the needle-bar 230 to its highest position the upper side of the extension 232''', Fig. 17, on the plate 232 strikes against the lower edge of the plate 233 and raises said plate 233 and the needle-bar 231 and allows the spring 236 to move the latch 235 to the position shown in Fig. 14. Meanwhile a spring (not shown) operates to move the angle-lever 239 and carry the rod 240 out of engagement with the hook 235' of the latch 235, as shown in Fig. 14. A stop 242 on the rod 238 engages the upper surface of the latch 235, as shown in Fig. 14, and prevents the needle-bar 231 from being carried up above a desired point. Each needle-bar 230 and 231 carries a series of separate needles 244, each of which in this instance is secured in a separate holder 243, which is supported on the needle-bars by means of extensions 243', between which the needle-bar extends. (See Fig. 15.) A set-screw 245 through the upper extension 243' engages the upper edge of the needle-bar and holds each needle in its desired adjusted position on the needle-bar.

In Fig. 19 is shown a modified construction of the needle-holder. In this figure the needle-holder 246 has a slotted extension 246' of sufficient length to act as a guide for the needle-bar 231. One or more of the needle-holders 246 will be placed near the center of the needle-bars to steady and keep the two sets of needles in proper alinement.

A series of pins 247 extend vertically

through the lay, Figs. 14 and 15, and are automatically raised at every pick to serve as a guide for the flying shuttle and as a protection to the forked needles 21 in the usual way.

It will be understood that the details of construction of our improvements may be varied, if desired, and we do not limit our invention to the particular mechanism shown in the drawings and described herein.

We are not aware that prior to our invention needles extending directly in front of the reed and having forked or two-pronged ends have ever been used in automatic cross-weave looms to engage certain of the warp-threads which are free of the needles until engaged and then by the movement of the needles carry said warp-threads over adjacent warp-threads or groups of warp-threads in the cross-weave operation.

Having thus described our invention, what we claim as new, and desire to secure by Letters Patent, is—

1. In automatic cross-weave mechanism for looms, a needle-bar carrying needles having forked or two-pronged ends to engage certain of the warp-threads, means for communicating a horizontal motion to the needle-bar and needles to carry the warp-threads engaged by the needles simultaneously past adjacent warp-threads, or groups of warp-threads, means for communicating a vertical motion to the needle-bar and needles to carry the warp-threads engaged by the needles vertically between the other warp-threads, to form one part of the shed, and means for moving the remaining warp-threads to form the other part of the shed, substantially as shown and described.

2. In automatic cross-weave mechanism for looms, a needle-bar carrying needles having two-pronged or forked lower ends to engage certain of the warp-threads, means for communicating a horizontal motion to the needle-bar and needles to carry the warp-threads engaged by the needles simultaneously over adjacent warp-threads, or groups of warp-threads, means for communicating a downward motion to the needle-bar and needles to carry the warp-threads engaged by the needles down between the other warp-threads, to form the bottom of the shed, the remaining warp-threads being raised to form the top of the shed, and means to return the needles to their normal position, substantially as shown and described.

3. In automatic cross-weave mechanism for looms, the combination with a needle-bar carrying needles with their lower ends forked or two-pronged to engage certain of the warp-threads, of means for communicating a horizontal motion to the needle-bar and needles to carry the warp-threads engaged by the needles simultaneously over adjacent warp-threads, or groups of warp-threads, and means for communicating a downward motion to the needle-bar and needles to carry the warp-

threads engaged by the needles down between the other warp-threads to form the bottom of the shed, the remaining warp-threads being raised to form the top of the shed, substantially as shown and described.

4. In automatic cross-weave mechanism for looms, the combination with a needle-bar carrying needles with forked ends to engage certain of the warp-threads, of means for communicating a horizontal motion to the needle-bar to carry the warp-threads engaged by the needles over adjacent warp-threads, or groups of warp-threads, said means consisting of a cam-surface, a sliding bar attached to the needle-bar and having a roll or surface engaging said cam-surface, and mechanism, intermediate the cam-surface and a jack of the dobbie or head motion, to communicate motion to the cam-surface toward and away from the needle-bar, by the raising of said jack, and control the horizontal movement of the needle-bar, substantially as shown and described.

5. In automatic cross-weave mechanism for looms, the combination with a needle-bar carrying needles with forked ends to engage certain of the warp-threads, of means for communicating a horizontal motion to the needle-bar to carry the warp-threads engaged by the needles over adjacent warp-threads, or groups of warp-threads, said means consisting of a cam-surface, a sliding bar attached to the needle-bar and having a roll or surface engaging said cam-surface, and mechanism intermediate the cam-surface and a jack of the dobbie or head motion, to communicate motion to the cam-surface toward and away from the needle-bar by the raising of said jack, to control the horizontal movement of the needle-bar, said mechanism consisting of a disk fast on a rod attached to the cam-surface, a bar or lever engaging said disk, a rotary cam engaging said lever and fast on a shaft, and said shaft, a ratchet fast thereon, a lever loose on said shaft and carrying a pawl engaging said ratchet, and connections from said lever to the jack, substantially as shown and described.

6. In automatic cross-weave mechanism for looms, the combination with a needle-bar carrying needles with forked ends to engage certain warp-threads, of means for communicating a downward motion to the needle-bar after a horizontal motion has been communicated thereto, to carry the warp-threads down between the other warp-threads to form the bottom of the shed, said means consisting of vertical rods, moving in guides and connected with the needle-bar, and the lower ends of said rods connected with a rock-shaft, and said rock-shaft, and connections therefrom to a centrally-pivoted lever, and said lever, and a spring attached thereto to maintain the lever in its normal position, and through intermediate connections the needle-bar in its raised position, connections from said lever to a jack, the raising of which acts to move said lever and allow the needle-bar to drop

by gravity, substantially as shown and described.

7. In automatic cross-weave mechanism for looms, the combination with a needle-bar carrying needles with forked ends to engage certain warp-threads, of means for communicating a downward motion to the needle-bar, after a horizontal motion has been communicated thereto, to carry the warp-threads down between the other warp-threads to form the bottom of the shed, said means consisting of vertical rods, moving in guides and connected with the needle-bar, and the lower ends of said rods connected with a rock-shaft, and said rock-shaft, and connections therefrom to a centrally-pivoted lever, and said lever, and a spring attached thereto to maintain the lever in its normal position, and through intermediate connections the needle in its raised position, connections from said lever to a jack, the raising of which acts to move said lever and allow the needle-bar to drop by gravity on the backward stroke of the lay, and to be positively raised on the forward stroke of the lay through the engagement of a roll or pin on an arm fast on said rock-shaft with a stationary cam-surface, and the engagement of said roll with said cam-surface limiting or determining the downward movement of the needle-bar and needles on the backward stroke of the lay, substantially as shown and described.

8. In a loom having automatic cross-weave mechanism, the combination with certain harness-frames which are engaged at one time in raising certain warp-threads, in the ordinary formation of the shed, and at another time are required to wait the crossing over of certain warp-threads carried by the needles, of two independent pattern-controlled mechanisms for separately actuating said harnesses, substantially as shown and described.

9. In the dobbie mechanism of a loom, the combination with the two knife-bars which operate the hook-levers, and through intermediate connections the harness-jacks, of a third knife-bar having a horizontal reciprocating motion independent of the motion of the first-mentioned knife-bars, and making one complete movement for a half-movement of the other knife-bars, and a hook-lever adapted to be engaged by said third knife-bar, and through intermediate connections operate or raise a harness-jack, the raising of said jack being delayed and occupying half the time of the raising of the other jacks, substantially as shown and described.

10. In the dobbie mechanism of a loom having automatic cross-weave mechanism, the combination with the two knife-bars which operate the hook-levers, and through intermediate connections the harness-jacks, of a third knife-bar having a horizontal reciprocating motion independent of the motion of the first-mentioned knife-bars, and making one complete movement for a half-movement

of the other knife-bars, and a hook-lever adapted to be engaged by said third knife-bar, and through intermediate connections operate or raise a harness-jack, the raising of said jack being delayed and occupying half the time of the raising of the other jacks, and mechanism, intermediate the jack and harness, controlled by the movement of said third knife-bar, said mechanism comprising a connector attached at one end to the jack, and at its other end to an offset or spoke on a pulley or sheave, and said sheave, and connectors attached at one end thereto and passing over pulleys, and secured at their other ends to the harness-frames, and springs intermediate said pulleys and harness-frame and connected with said connectors, substantially as shown and described.

11. In a loom having automatic cross-weave mechanism, a harness-frame having two sets of connectors, and two independent pattern-controlled mechanisms operating in different times to vary the time of raising said harness-frame, substantially as shown and described.

12. In the warp-easing mechanism of a loom, the combination with a vertically-moving rod carrying an engaging plate, and means for moving said rod and plate, of a rocking lever, connections intermediate said lever and a roll over which the warp-threads pass, said rocking lever having an extension thereon, and a pivoted lever at its free end, for the purpose stated, and connections intermediate said pivoted lever and a jack, the movement of said jack controlling the movement of said pivoted lever, and the easing of the warp-threads, substantially as shown and described.

13. In the warp-easing mechanism of a loom, a rocking lever, a roll or rod over which the warp-threads pass, connections intermediate said lever and roll or rod, so that they will move together, a pivoted lever on the free end of the rocking lever, means for holding it in its normal position, and means for moving it into operative position, said means controlled by the pattern mechanism, and means for engaging and moving said pivoted lever, to ease the warp, substantially as shown and described.

14. In the dobby mechanism of a loom, the combination with two reciprocating knife-bars, hooked levers to engage the knife-bars, the pattern-surface, and connections intermediate the pattern-surface and said hooked levers, of a third reciprocating knife-bar, a lever supported on the upper hooked lever, to engage said knife-bar at its free end, and pivoted at its other end to a rocking lever, and said lever or supplemental jack, a spring connected thereto, and connections from said lever to a harness-frame to move said frame, substantially as shown and described.

15. The combination with a needle-bar, carrying needles, and adapted to have a horizontal and a vertical movement, of a second needle-bar carrying needles, connected and adapted to move with the first-mentioned

needle-bar, and also adapted to be disconnected therefrom, to remain stationary during the movement of the first-mentioned needle-bar, substantially as shown and described.

16. The combination with a needle-bar carrying needles and adapted to have a horizontal and a vertical movement, of a second needle-bar carrying needles, connected to and adapted to move with the first-mentioned needle-bar, and also adapted to be disconnected therefrom, to remain stationary during the movement of the first-mentioned needle-bar, and connections intermediate the second needle-bar, and a jack which controls the movement of the second needle-bar, substantially as shown and described.

17. The combination with a needle-bar, of a needle-holder having a slotted extension, to act as a guide for a second needle-bar carrying needles, substantially as shown and described.

18. A needle for cross-weaving, having a forked or two-pronged end to engage a warp-thread in the space between the forks or prongs on movement of the needle toward the same.

19. In a cross-weave loom, the combination with a needle-bar, of needles attached thereto to move therewith, said needles having forked or two-pronged ends to engage the warp-threads between the forks or prongs on movement of the needles toward the same, substantially as shown and described.

20. In automatic cross-weave mechanism for looms, the combination with a needle-bar carrying needles with forked or two-pronged ends to engage and move certain of the warp-threads on movement of the needles in a direction toward said threads and cross them over certain adjacent warp-threads, of means for controlling the lateral motion of said needles and their engaged warp-threads, substantially as shown and described.

21. In automatic cross-weave mechanism for looms, the combination with a needle-bar carrying needles with forked or two-pronged ends to engage certain of the warp-threads and cross them over certain adjacent warp-threads, of means for controlling the lateral motion of said needles and their engaged warp-threads, said means consisting of a cam-plate moved by a revolving cam controlled by the pattern mechanism, substantially as shown and described.

22. In automatic cross-weave mechanism for looms, the combination with a needle-bar carrying needles with forked or two-pronged ends to engage certain of the warp-threads, of means for moving the said needles horizontally to engage a predetermined warp-thread, or set of warp-threads, substantially as shown and described.

23. In automatic cross-weave mechanism for looms, the combination with a needle-bar carrying needles with forked or two-pronged ends to engage certain of the warp-threads,

of means for moving the said needles horizontally to engage a predetermined warp-thread, or set of warp-threads, said means consisting of a guide-plate moved by a revolving cam controlled by the harness mechanism, substantially as shown and described.

24. In automatic cross-weave mechanism for looms, a needle-bar carrying needles with their lower ends forked or two-pronged to engage certain of the warp-threads, means for communicating horizontal motion to the selected warp-threads by said needles, to thereby cross the said selected warp-threads over a thread, or set of adjacent threads, substantially as shown and described.

25. In automatic cross-weave mechanism for looms, the combination with a series of needles extending directly in front of the reed and having forked or two-pronged ends, of means for moving said needles in a horizontal plane, and in a vertical plane, and then returning them to their normal position, substantially as shown and described.

26. In automatic cross-weave mechanism for looms, the combination with a series of needles extending directly in front of the reed and having forked or two-pronged ends, of means for moving said needles in a horizontal plane to engage a portion of the warps, and then to move them in a vertical plane, and also the warp-threads engaged by said needles, the other warp-threads being moved in a vertical plane in an opposite direction to form the shed, while the reed is in its backward position, substantially as shown and described.

27. In automatic cross-weave mechanism for looms, the combination with a series of needles which extend directly in front of the reed, and have forked or two-pronged ends, of means for moving said needles in a horizontal plane to cause them to engage a portion of the warp-threads, and then move them in a vertical plane, and the warp-threads with them, the other warp-threads being moved in a vertical plane in an opposite direction, to form the shed for the insertion of a filling in the shed thus formed, while the reed is in its backward position, substantially as shown and described.

28. In automatic cross-weave mechanism for looms, the combination with a series of needles which extend directly in front of the reed, and have forked or two-pronged ends, of means to move said needles in a horizontal plane to engage a portion of the upper shed of the warp, and then move said needles in a vertical plane to carry the warp-threads so engaged into the plane of the lower shed and across a portion of the warps of said lower shed, said warps being moved into the upper plane of the shed, so that a filling-thread may

be inserted into the open shed thus formed, while the reed is in its backward position, and means to return said needles to their normal position, substantially as shown and described.

29. In automatic cross-weave mechanism for looms, a series of warp engagers or needles, having forked or two-pronged ends extending in front of the reed, and coating means to move said warp engagers or needles, to place the forked or two-pronged ends between the warp-threads of one of the planes of the shed, and cause them to move portions of said warp-threads, both crosswise and to the other plane of the shed, and means to move the portion of the warp-threads of said other plane of the shed to their opposite plane, to form a new shed for the insertion of a filling-thread, and means to return said warp engagers or needles to their normal position, all during one back-and-forth movement of the reed, substantially as shown and described.

30. In a loom having automatic cross-weave mechanism, the combination of harness-frames and means to operate them in the formation of a shed, and an auxiliary pattern-controlled mechanism independent of said means and adapted to act on some of said harness-frames in addition to said means.

31. In a loom having automatic cross-weave mechanism, the combination of a roll over which the warp-threads pass, a rod for moving said roll to ease the warp-threads, and pattern-controlled means for operatively connecting and disconnecting the rod and roll.

32. In a warp-easing mechanism for looms, a rocking lever, a roll or rod over which the warp-threads pass controlled by said lever, a pivoted lever carried by the free end of the rocking lever, a reciprocating rod for moving the rocking lever by engagement with the said pivoted lever, and pattern-controlled means to determine the engagement of the rod and pivoted lever.

33. In an automatic cross-weave mechanism for looms, the combination with a needle-bar carrying needles having forked or two-pronged ends, and means for communicating a horizontal motion to the needle-bar, said means comprising a cam-surface, a sliding bar connected to the needle-bar and carrying a surface or roll to engage said cam-surface, and pattern-controlled mechanism to communicate motion to the cam-surface to determine the position of the cam-surface and horizontal movement of the needle-bar.

GEORGE F. HUTCHINS.  
EPPA H. RYON.

Witnesses:

J. C. DEWEY,  
M. HAAS.