

HOW TO BUILD A LOOM

Edward F. Worst

The following cuts show the working drawings for both the Danish and Swedish looms. Both are counterbalance with swinging beaters. If light work only is desired the Danish loom is the one to construct.

If space is available the Swedish loom is preferable. On this loom very fine articles may be woven as well as the Colonial rugs. On the Danish loom only the lighter work can be successfully woven.

The fly shuttle arrangement is especially practical in the weaving of materials that require but one shuttle. The batten or beater of any loom may be made into that of a fly shuttle.

Working drawings for accessories are also included.

New addition to the 1973 printing - How to add and tie up a contramarche (also called countermarch or double tie-up) and how to make the loom into a jack type loom. Page 17-19.

Originally printed in 1918
Reprinted in 1971 and 1973

Select Books

POST OFFICE BOX 626
PACIFIC GROVE, CALIFORNIA 93950

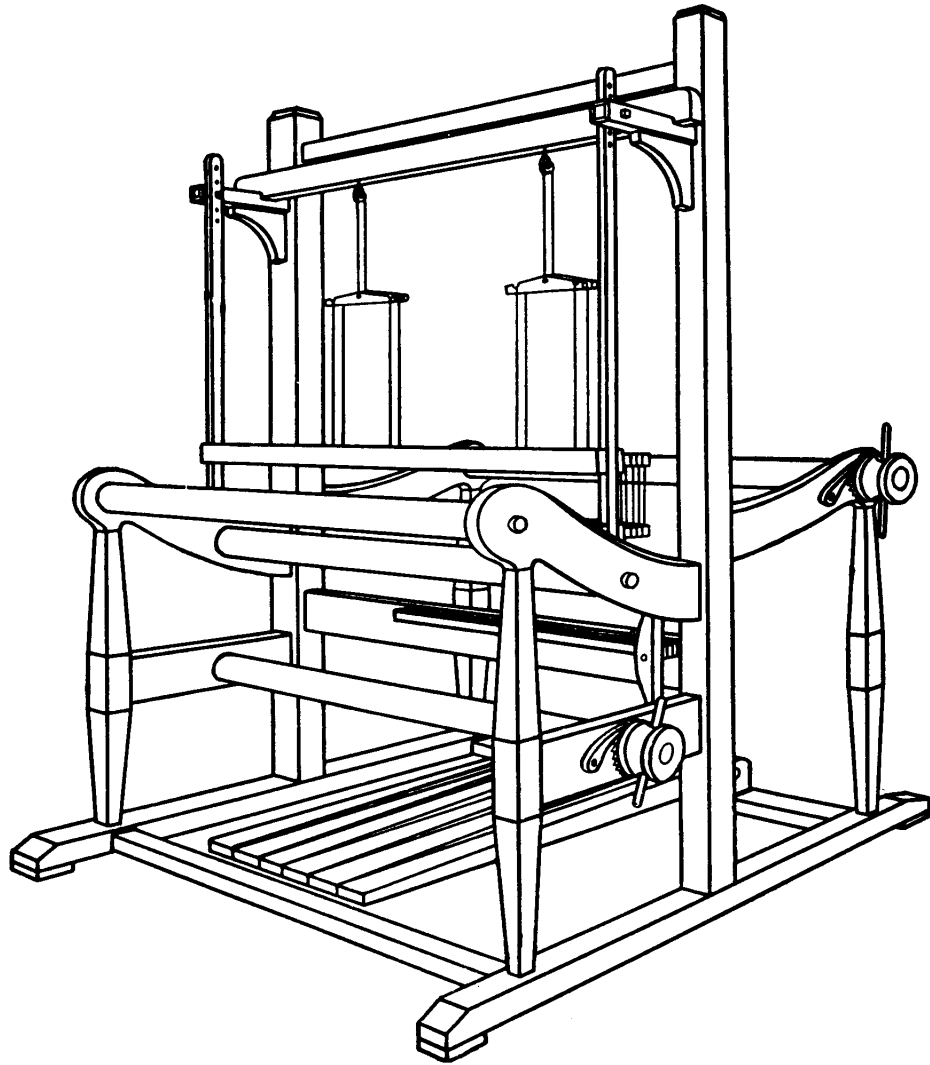

Sketch of Danish Loom

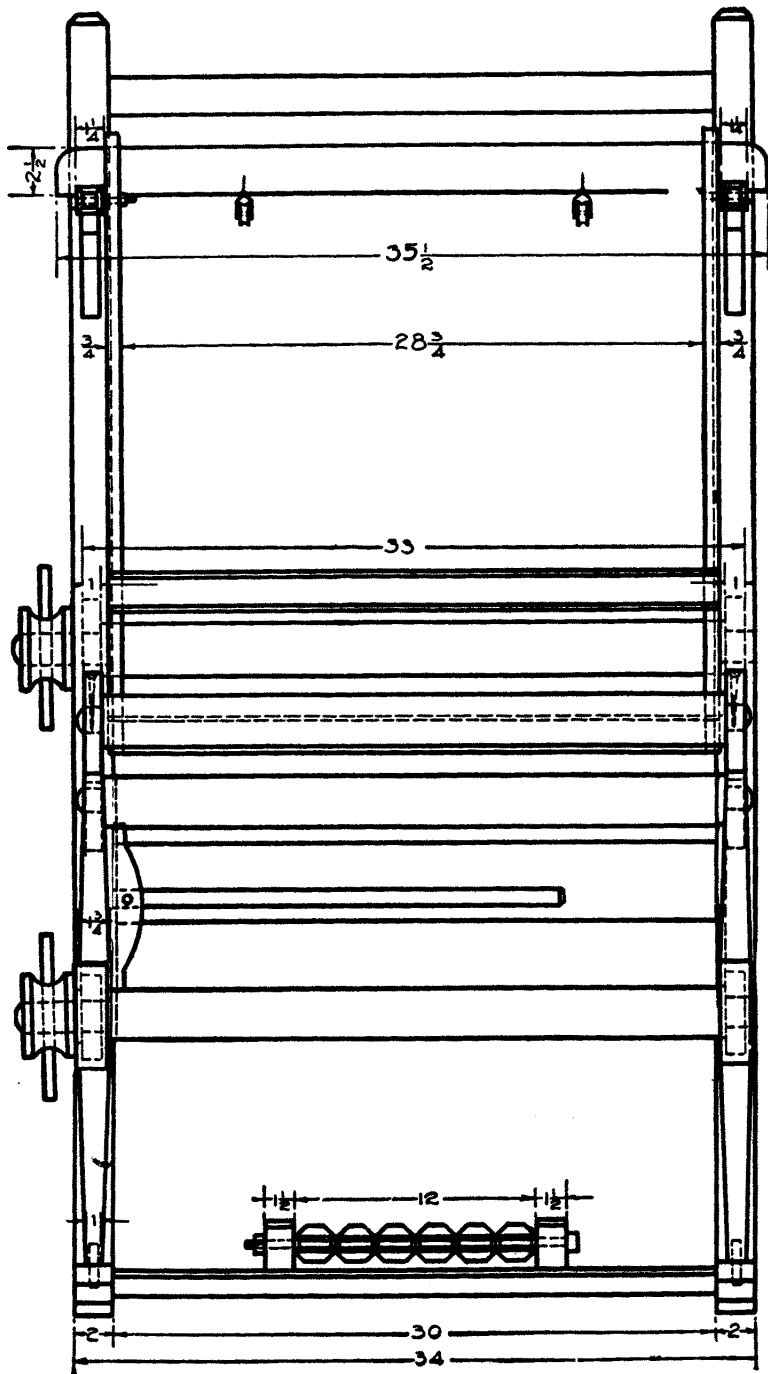

Working Drawing of Loom

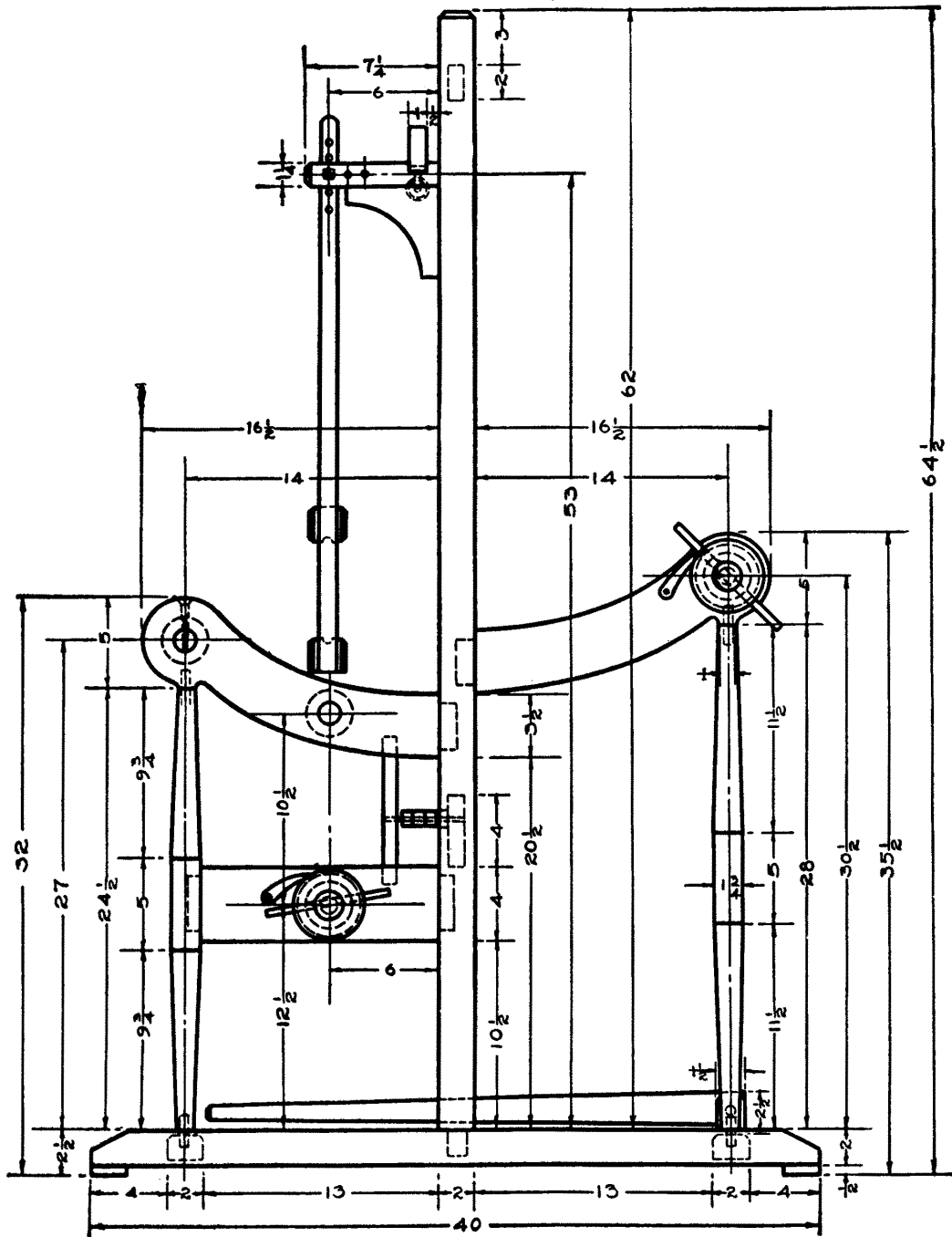

Working Drawing of Loom—Side View

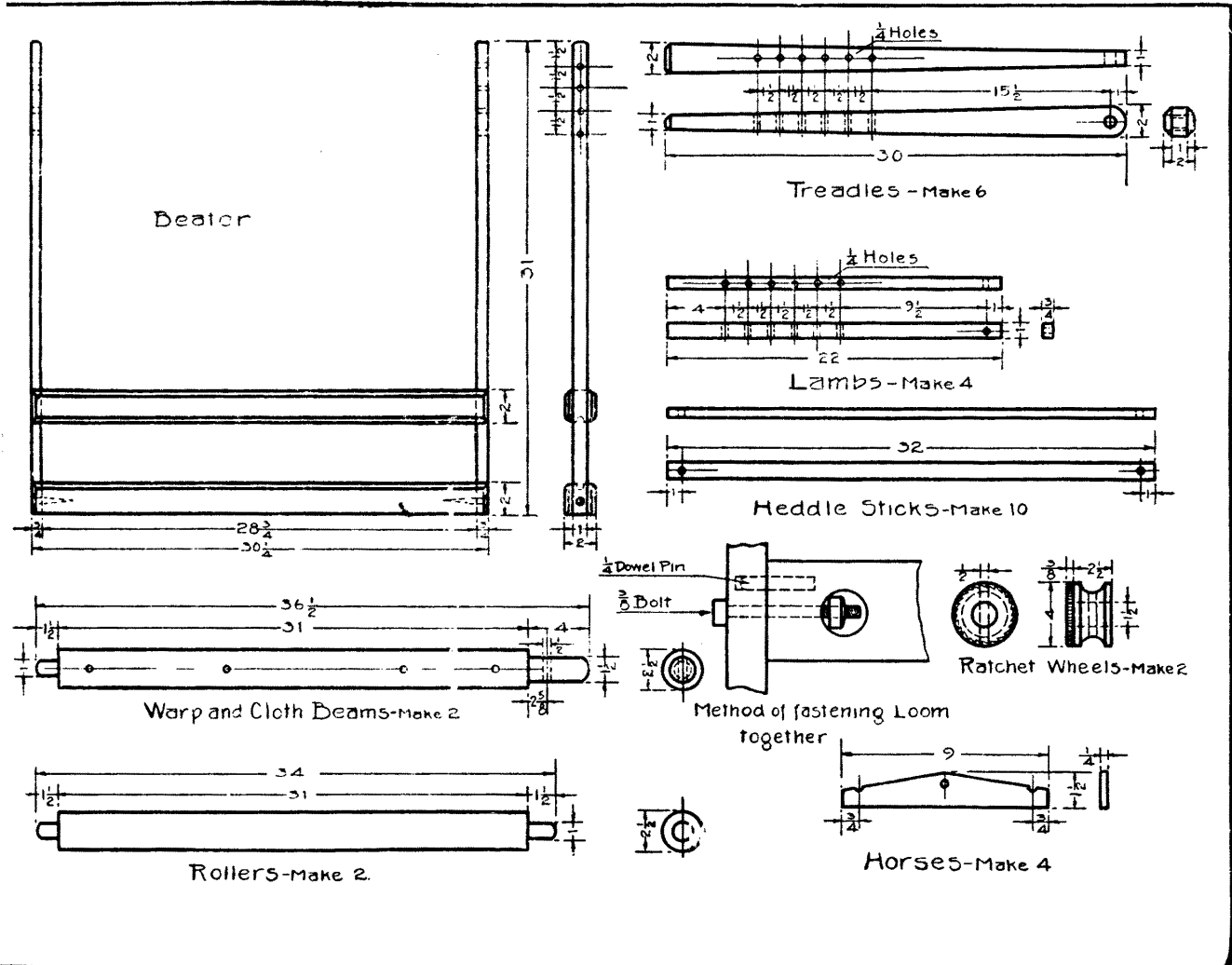

Working Drawing of Loom—Details

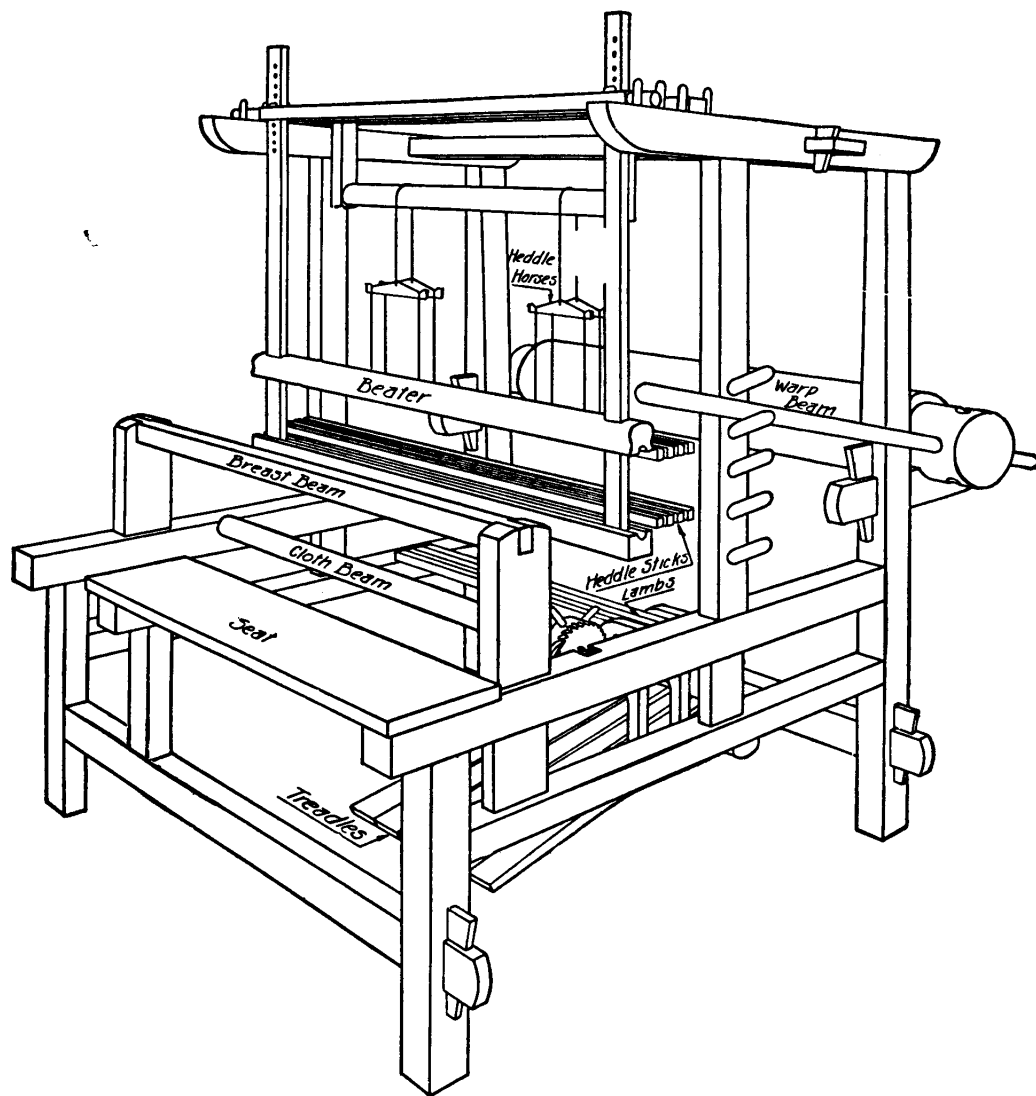

Finished Loom—Swedish

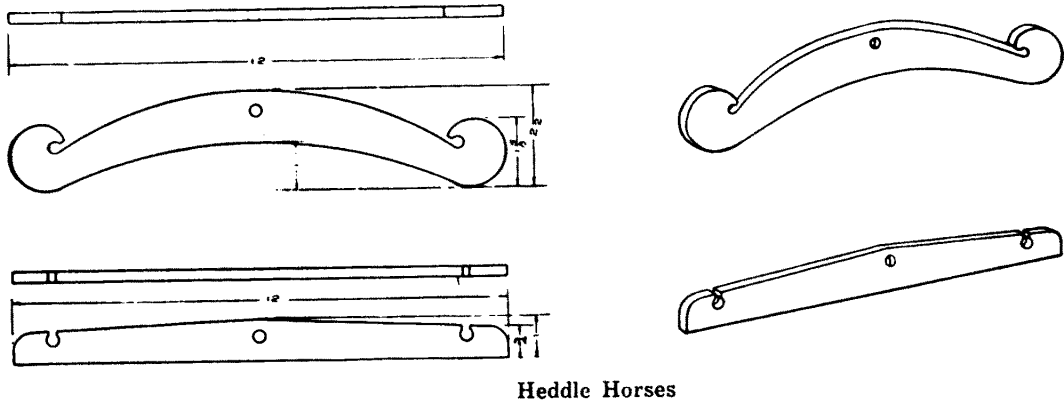

Heddle Horses

KNOTTING THE HEDDLES

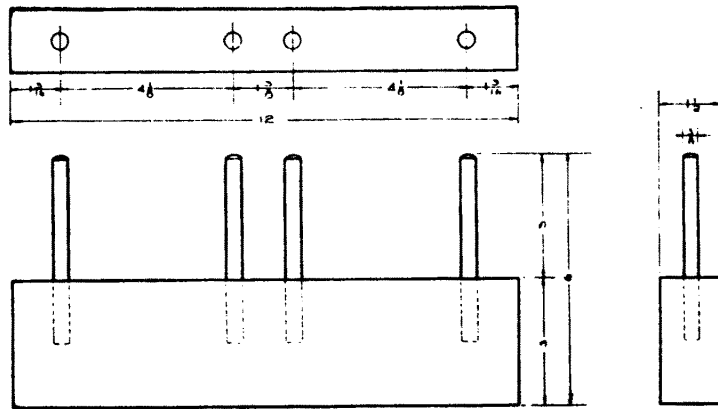
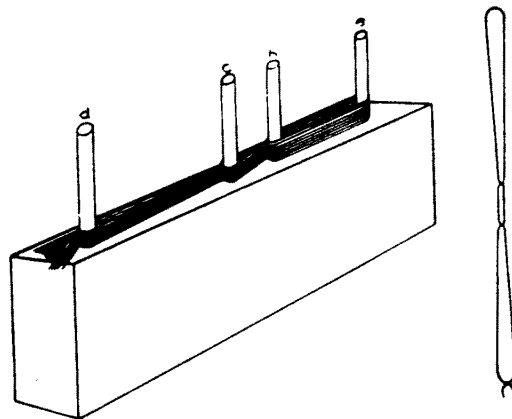
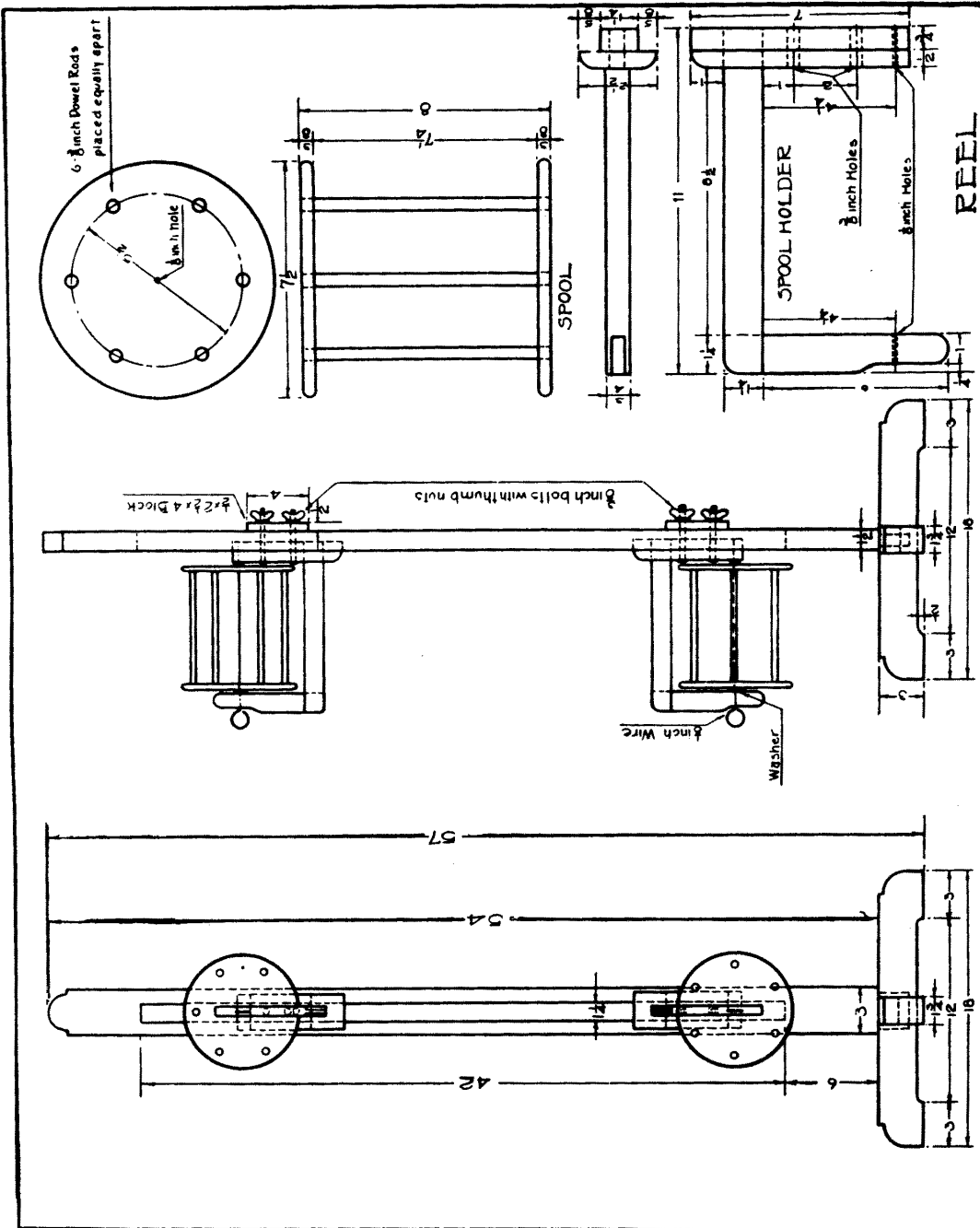

Fig. 29—Working Drawing of Heddle Frame



Method of Tying Heddles



Working Drawing of Floor Swift

THE WARP SPREADER

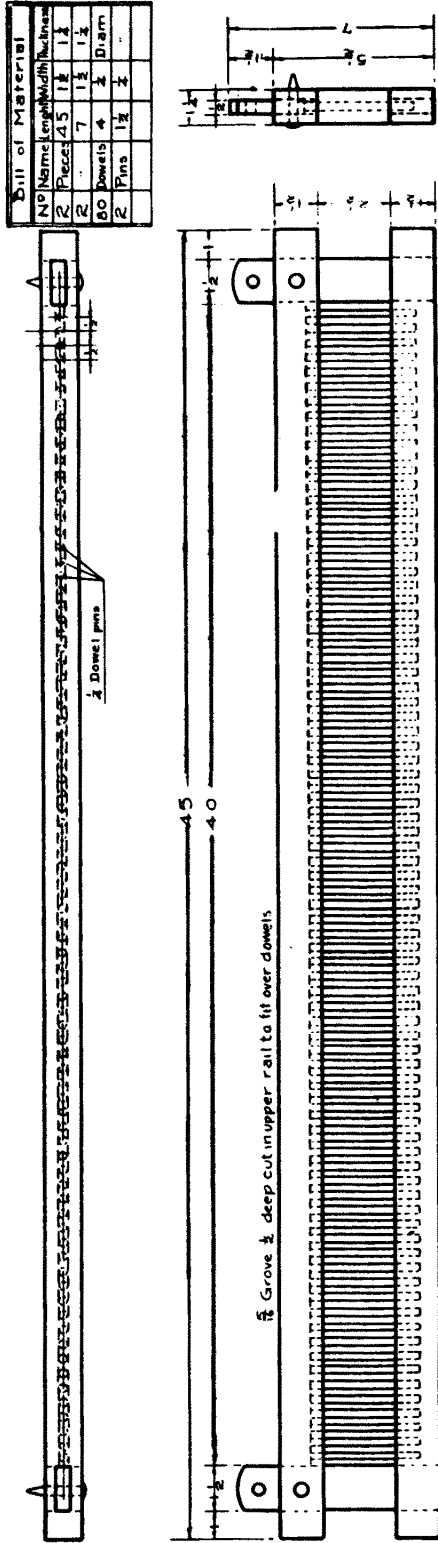

Working Drawing of Warp Spreader or Raddle

The spreader is most simply described as a comb, with a movable cap to cover the ends of the teeth. The frame is made of wood. The teeth may be made of dowel rods or hard wire. Nails have sometimes been used. The cap is deeply grooved above the teeth and has holes near the ends. Through these holes the sides of the frame pass in order to fix it on.

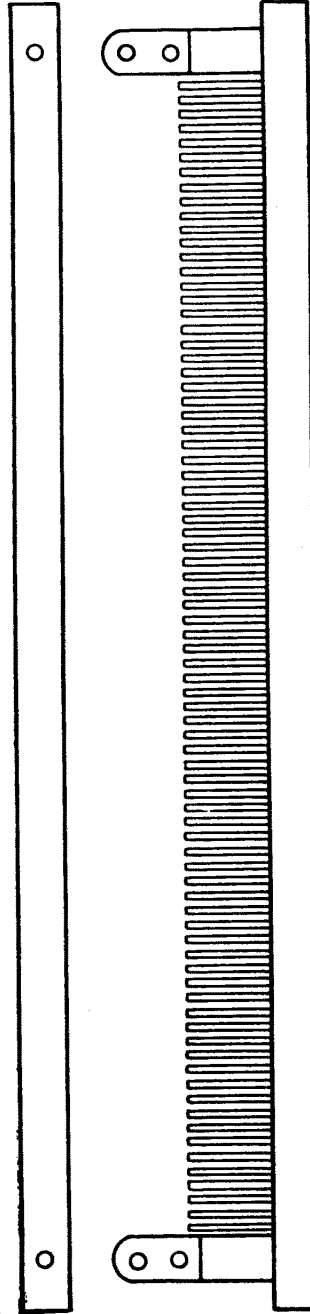

Warp Spreader with Cap Removed

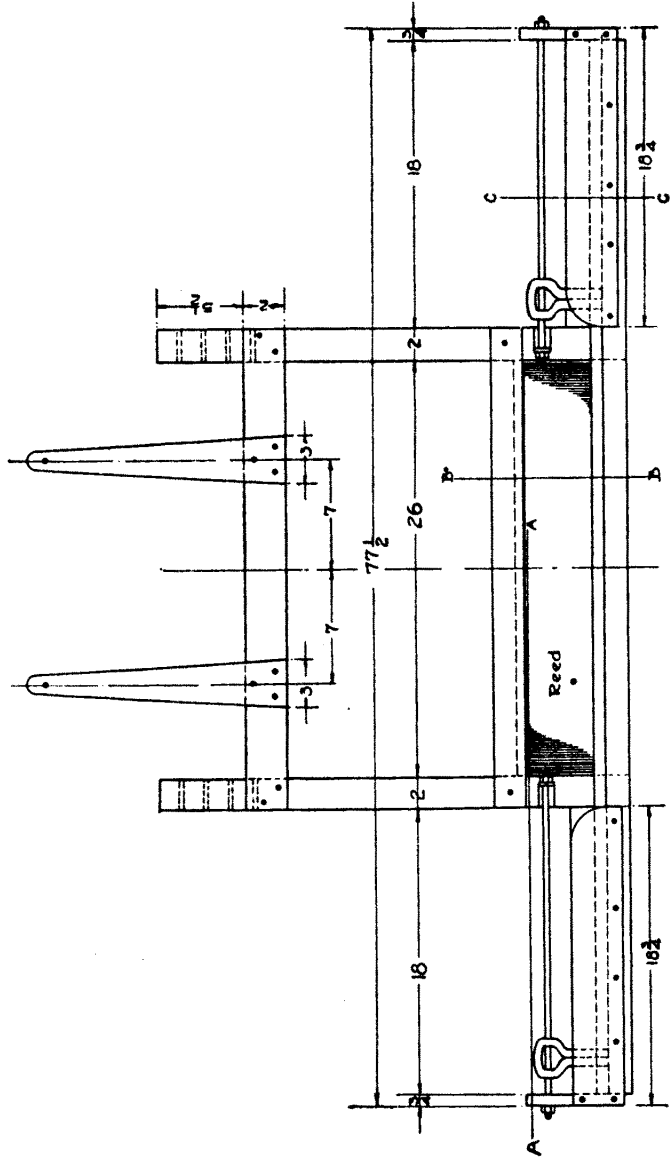
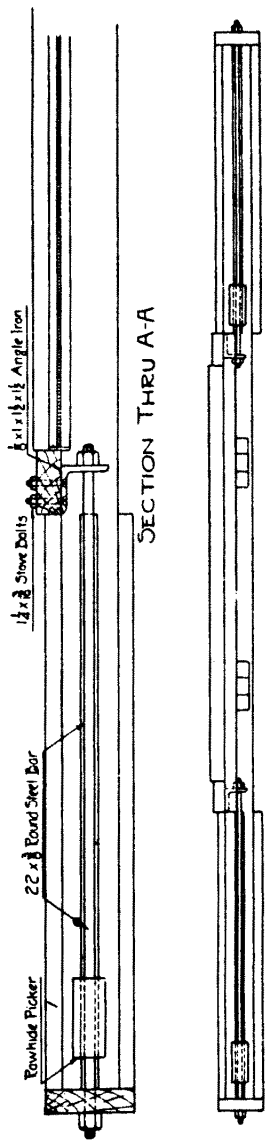
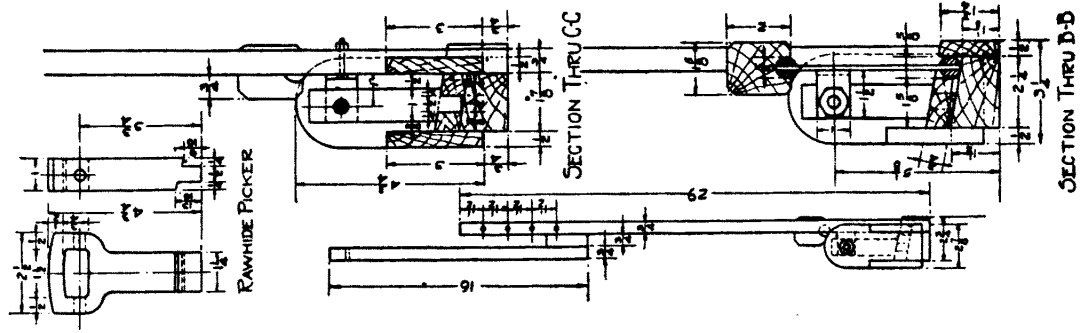

FLY SHUTTLE BEATER

Fly Shuttle

Another Way of "Tie-Up"

Figure 262 shows a way of "tie-up" that requires two sets of lams. The second set of lams may be held in place by an iron rod pushed through the same brackets which hold the upper lams, only lower down. This is shown in the construction of the loom. The loom should be about four inches higher in order to give sufficient space for the two sets of lams. This may be brought about by adding a four-inch piece to each leg of the loom. For all ordinary purposes the original working drawing of the loom answers all conditions. By using this method the heddle horses are done away with, and each harness is tied so it must pull either up or down when pressure is applied to the treadle. The roller over which the heddle horses are hung is removed and replaced by the apparatus shown at A and B, Fig. 262. A detailed section is shown at Fig. 263. If an eight-harness loom is desired, sixteen pieces are constructed as shown in Fig. 263. Eight of these are placed to the right upper half of the loom and the other eight to the left upper half. The various sections are held in place by a half-inch dowel rod as shown at 1 and 2, Fig. 262. The rods are supported by two pieces of $\frac{7}{8}$ " maple constructed as shown in Fig. 264. This sort of frame work replaces the roller as shown in the finished loom in Fig. 265.

The "Tie-Up"

Returning to Fig. 262, loops of No. 12 blocking cord are tied and hung from each outer end of the levers as shown at C and D in Fig. 262. Two ends of the cord are

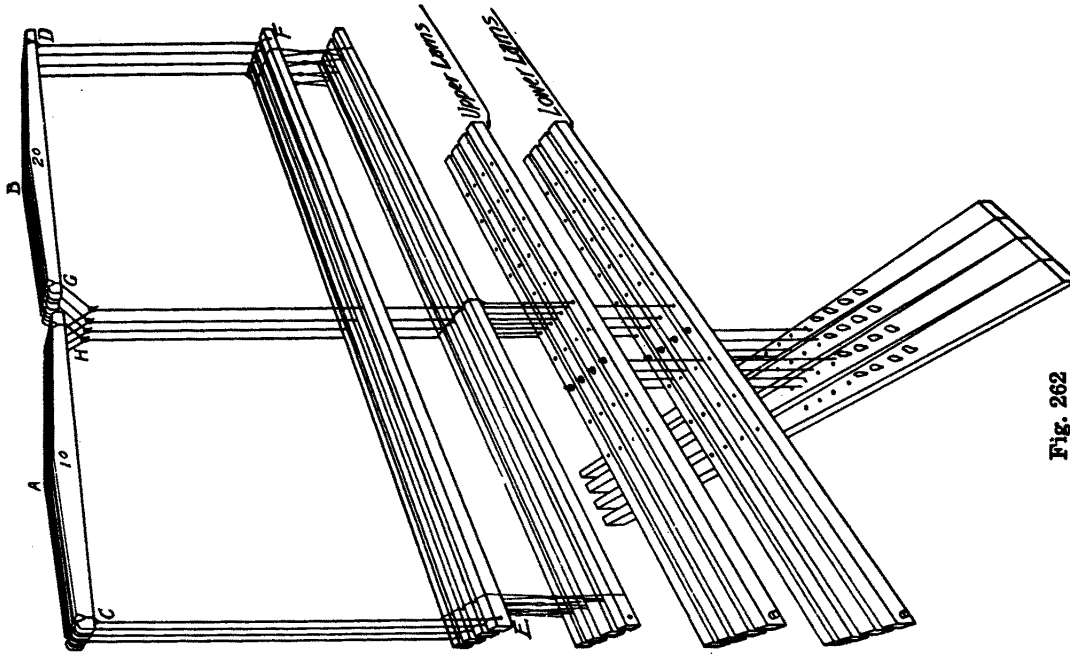

Fig. 262

fastened to each end of the upper heddle sticks, as shown at E and F. The loops and ends are tied just the same as the treadles are tied to the lams. From the inner ends of the levers H and G, a piece of blocking cord is tied, one end to one, and the other end to the other as shown. From each loop a piece of blocking cord extends to the lower set of lams by passing between the harness and ties the same

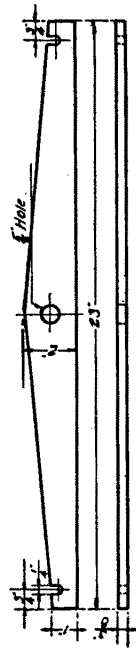

Fig. 263

as all other connections have been made. Each lower heddle stick ties to an upper lam the same as in the two and four-harness looms. Loops of blocking cord are now drawn through the holes of the treadles, one in each. The upper lams are tied to the treadles the same as in every

other "tie-up," the cord passing between the lower lams. The lower lams are also tied to the treadles by using the loops not used in tying the upper lams.

By tying a loom in this way all harnesses making the pattern are drawn down while the other harnesses are drawn up. No part remains stationary. The weights previously mentioned for drawing the harnesses back in place are no longer necessary. Fig. 262 shows only a four-treadle loom. This is done to avoid complication in the explanation. Any number may be used. This method of tie-up is especially desirable when an odd number of heddle sticks (harnesses) are used. It does away with pulleys and heddle horses, as shown by Fig. 265. The fact that each part of the harness must either pull up or down makes a most perfect shed, thus avoiding the skipping of threads, so common in weaving when the shed is not perfect.

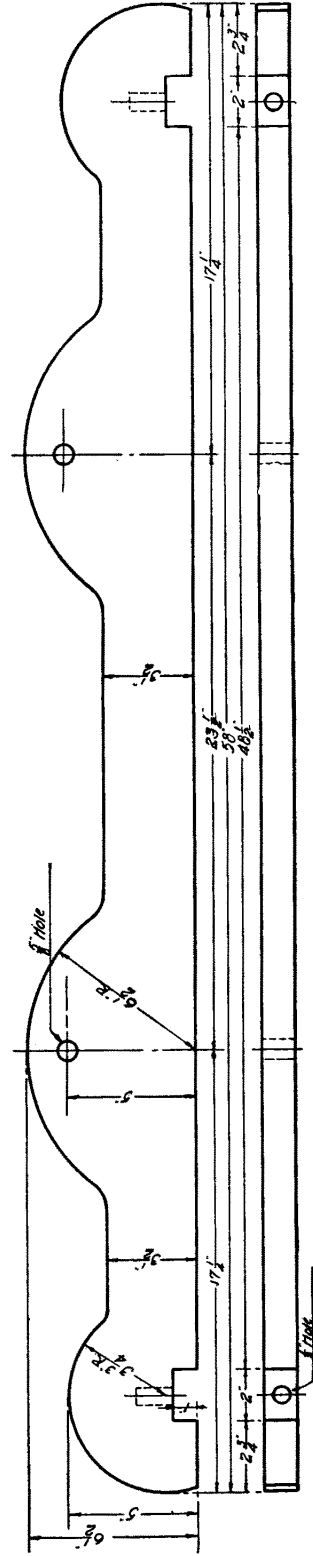

Fig. 264

SWEDISH LOOM

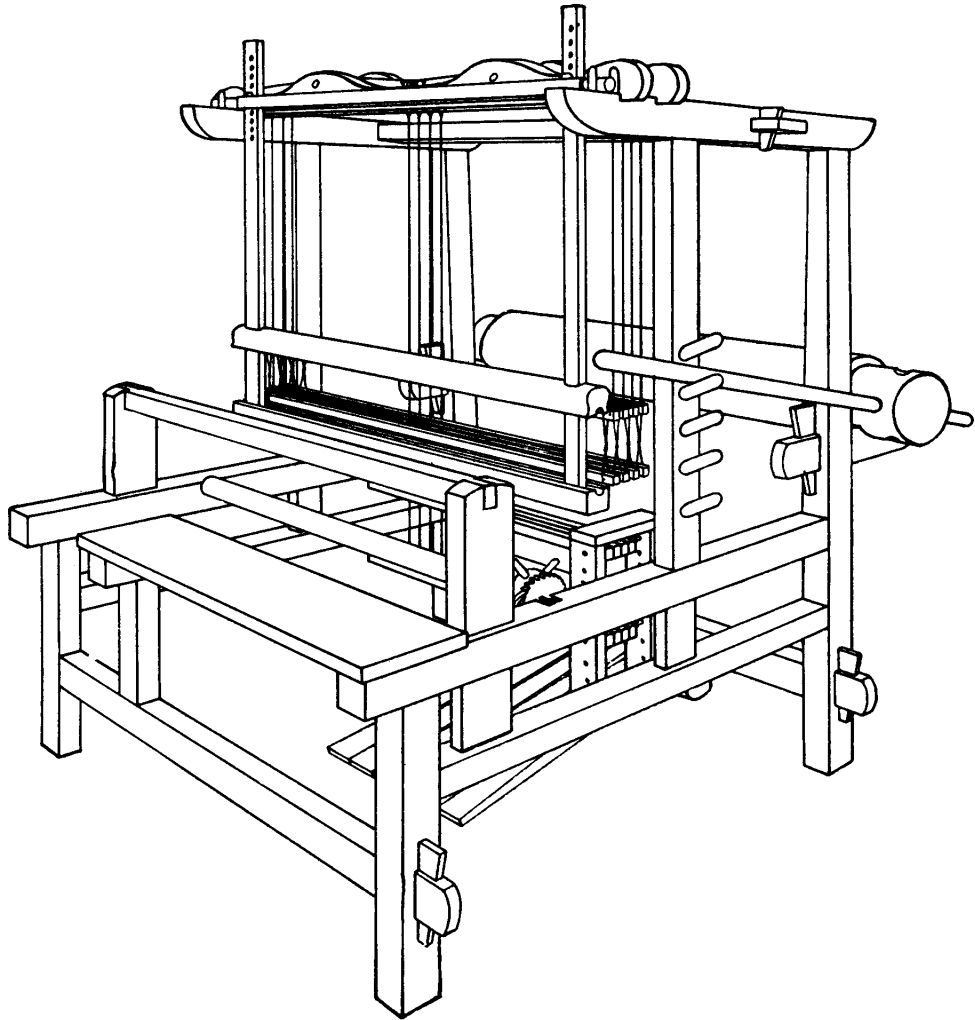

Fig. 265