

# WOOL MIXING

## INTRODUCTION

**1. Importance of Proper Mixing.**—Although the importance of proper methods of *mixing* stock before subjecting it to the carding process is often underrated, it may be stated with truth that the character of the yarn ultimately produced depends, to a great extent, on the manipulation of the stock at this point. **Mixing** is the blending, or amalgamation, of different colors or qualities of wool, or of wool and cotton, wool and shoddy, or similar materials, and is resorted to for various purposes. Sometimes the mixture is simply one of colors; for instance, it may be desired to produce a gray mix; this result will be obtained by blending wool that has been dyed black with pure white stock in proportion to the shade of gray desired in the mixed yarn. Again it may be found that a certain grade of goods is costing too much. In such a case, if the cost of production is already reduced to a minimum, the only recourse is to reduce the cost of the material entering into the goods. If a high grade of goods is being made, the cost of the material may be reduced by blending a cheaper grade of wool with the finer stock previously used. If a medium grade of goods is being manufactured, a little shoddy or cotton may be mixed with the stock; while if the lowest grades of goods possible are being made, various kinds of fibers may be blended together, material possessing any spinning qualities at all being of value.

**2.** At first thought it would seem a comparatively simple matter to mix two or more materials together and spin a yarn from the blended stock, but when it is considered that the materials to be mixed are often radically different in physical

*For notice of copyright, see page immediately following the title page*

structure and that they should be so blended as to be indistinguishable one from the other, the difficulty will be recognized. The yarn spun from the mixed stock should also be as even and level as though only one material were used and, if the mixture is one of color, the blend should be so perfect that the colors of the original ingredients cannot be distinguished except on close inspection.

It matters little how perfect are the color and the design of a fabric, or how carefully the other processes of manufacture are accomplished, if the mixing of the raw stock has been carelessly or imperfectly performed, the finished cloth will show more or less imperfections. Sometimes the cloth will be covered with specks, usually of the lighter-colored stock used in the mix; such cloth must either be sold for seconds or piece-dyed. A thread composed of poorly mixed materials when examined under a microscope reveals, instead of the perfect amalgamation of the individual fibers of different materials, a mass of the fibers of one material in one part and a mass of the other in another part of the thread. The evenness of the thread itself is liable to imperfections, since it is impossible to spin an even thread from unevenly mixed stock. Especially is this true in a case where the mix is composed of materials of different spinning properties and of different lengths of staple. In cases like this the roving will not draw well in spinning and the yarn will be liable to contain *twits*. If the spinner cannot make a first-class yarn out of poorly mixed materials, neither can the weaver make a perfect piece of cloth from an inferior yarn, nor the dyer and finisher produce superior results.

**3.** Mixing is resorted to, not only for combining colors or qualities of stock, but is also occasionally used in the best mills in lots of one color and quality, since any mistakes in sorting, scouring, dyeing, etc. are by this process equally distributed through the entire batch. The more that wool is mixed and worked over, without injury to its natural qualities, length of staple, and physical structure, the evener will be the yarn and cloth made from it.

### METHOD OF LAYING OUT MIXES

4. Whatever may be the materials to be mixed, the same general method is followed in mixing; for though the process of mixing has been in use for many years no improvement has been found on the old method, which consists of spreading the materials to be mixed in thin alternate layers on the floor of the picker room. For a simple example, suppose that a gray mix composed of 50 per cent. black and 50 per cent. white wool is required; the method of procedure will be as follows: Equal quantities of black and white wool will be weighed out first and then, on a clean floor space in the picker room, a layer of black wool will be spread about 10 or 12 feet square, depending on the number of pounds of stock to be mixed, and 7 or 8 inches in depth, care being taken to have it spread evenly and of uniform depth. Then a similar layer of white wool will be spread over the first layer of black, care being taken to have approximately the same quantity of stock in the layer of white as in the layer of black wool. Then another layer of black, then white, and so on until the lot is completed.

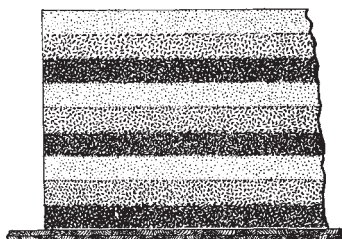

FIG. 1

The mix is now ready to be put through a mixing picker. In taking the stock from the pile on the floor, great care should be taken to break it down from the side or end and not from the top; otherwise, the benefit of laying out the stock in successive layers is lost. If the stock, however, is taken carefully from the end, a portion of each layer will go into the self-feed of the mixing picker in every armful. It is customary to oil the stock as each layer is spread during the mixing, but this process will be described later. In many

instances, a mix contains more than two materials; in some cases three, four, or even more components enter into the mixture.

Fig. 1 represents the mixing of three colors of the same material, or three materials. In the illustration, the dark-shaded divisions represent material or color No. 1; the medium-shaded divisions, material or color No. 2; and the light-shaded divisions, material or color No. 3.

**5.** In making fancy mixes, sometimes with a little study advantageous methods of laying out the mix may be devised; for instance, suppose that a fancy mix composed of 50 per cent. black wool, 25 per cent. white, and 25 per cent. olive is required. If the layers were laid out on the floor in the order and percentages given, to make the individual piles of different-colored wools come out even, or be used up at the same time, it would be necessary to make the layers of black wool twice as thick as those of either the white or olive wool. This would not distribute the different ingredients so well as when the layers of stock were made of the same thickness and distributed in the following order: black, white, black, olive; this process would be repeated until the wool were all used up, and if the layers were of the same thickness they would come out even. This method, of course, would be impossible if there were only two ingredients in the mix.

**6.** In laying out a mix containing different percentages of materials, where it is not possible to divide the stock so that each layer shall be of the same thickness, care should be taken to make the layers of each material vary in thickness as near as possible according to the percentage of that material in the total blend; otherwise, the ingredient of which there is the smallest amount will soon be exhausted and the rest will have to go on top, thus destroying the evenness of distribution and the uniformity of the blend.

In dealing with mixes of great diversity of quantity as well as color and quality of components, it is often customary to prepare a temporary mix with the small quantity and a part of the larger quantity of material and then finally blend

this temporary mix with the rest of the stock. In this manner the small quantity of one ingredient is more evenly distributed through the large amount of the other. For instance, suppose that a mix composed of 90 per cent. black and 10 per cent. white is required. If these are mixed directly there is such a small amount of white present that it will be difficult to distribute it evenly, so that if the amount of mix required is 500 pounds, a temporary mix of 50 pounds of white and 100 pounds of black making a mix of 150 pounds will be prepared. The temporary 150-pound mix will then be mixed with 350 pounds of black, making 500 pounds of the final mix, which will contain only 50 pounds, or 10 per cent., of white wool.

7. In mixes where several colors are used, it is sometimes the custom to mix the smaller proportioned colors together first and run them through the mixing picker, and afterwards mix this temporary mix with the color that occurs in the greatest proportion. For instance, if a mix were being made of 40 per cent. black, 20 per cent. brown, 20 per cent. olive, and 20 per cent. slate, the custom would be to first mix the brown, olive, and slate and afterwards blend this temporary mix with the black. This would insure the colors being more evenly distributed.

In making a mix where there is an extremely small amount of one ingredient, such as an Oxford mix containing 97 per cent. of black and 3 per cent. of white, it is customary to card that stock which enters into the blend only in a small percentage before it is mixed, in order to make it more lofty and enable it to be more uniformly distributed. This is usually accomplished by having an extra breaker card and allowing the stock to drop on the floor from the doffer comb. Or, if this is not convenient, it may be run through the mixing picker several times before mixing. These machines will be fully explained further on.

8. Care must be taken in making fine mixes to have all the materials of approximately the same length of fiber if the best results are to be obtained. If short fibers are

mixed with long ones, that is, extremely long in comparison, they do not strengthen the yarn to a great extent, although they make the yarn more bulky. There is also a tendency for the short fibers to bunch up during the carding and the drafting of the roving in spinning and produce twits in the yarn.

In regard to the number of times that a mix is passed through the mixing picker, little can be said, as it all depends on the condition in which the stock is received from the preceding processes and the materials and colors that are being blended. If the stock is well opened and lofty and the mix is carefully made, it will probably not be run through more than twice. Some materials are more difficult to blend thoroughly than others and some colors also have a tendency to show up more than others if not thoroughly amalgamated, even if the stock is the same. The only way to tell whether the stock needs to be passed through the mixing picker again is to examine the mix and see if the fibers are well and evenly blended; if not, and they occur in separate patches, it is well to run the mix through the picker again. Some mills make a practice of running mixes through the picker three times, while others consider twice sufficient. Definite rules, however, should never be allowed to regulate the handling of all mixes.

**9. Mixing Wool and Shoddy.**—In view of the competition that is now prevalent, many manufacturers deem it wise to mix varying percentages of cheaper material into their goods in order to gain the market against a competitor by underselling him. One of the materials mixed with the wool to cheapen the cost of the raw stock is **shoddy**. This material is, literally, the worked up waste of old, soft, woolen fabrics, such as stockings, knitted fabrics, flannels, and other woolen goods that have not been milled or felted; but in the mill the card waste, strippings, etc. are sometimes considered as shoddy and after being dusted are worked up with the new wool. Usually, however, soft waste is worked up as far as possible with the batch in which it was

made, but hard waste is run through a Garnett machine or rag picker and made into shoddy.

In order to make a good mix with shoddy, a short, fine wool will be found to give the best results in the majority of cases. The reason for this is that the shoddy fibers are always of extremely short length and it is difficult to mix a long fiber with a short one and get good results. In selecting shoddy to mix with wool, the length of the shoddy fiber is one of the main points to be observed; the longer the fiber, the more valuable is the shoddy. Where a mill is buying shoddy, care should be taken that it is not adulterated as, the fiber being naturally short, it is easy to adulterate it with extremely short and inferior material that can hardly be detected. Shoddy is not often worked alone, as the resulting yarn would be tender and almost impossible to spin, but in mixtures with pure wool the shoddy has its purpose in *feeding* the yarn, or making it more bulky.

**10.** The percentage of shoddy used depends on the class of goods that a mill is running on. If a good grade of goods is being made, it is not wise to cheapen the stock too much and, even if shoddy is used, care should be taken to use a good grade; on the other hand, if the goods are cheap, often the larger part of the fabric is shoddy with only enough new wool fibers to hold the yarn together. In blending wool and shoddy, it is a good practice first to run the materials through the picker separately and then to make a mix on the floor by spreading the materials over each other in successive layers. The thinner the layers of the different materials and the more of such layers, the better is the mix.

In running a blend through the mixing picker, it must always be remembered that the success of the mixing depends largely on the manner in which the stock is taken from the pile spread out on the floor. The stock must always be removed from this pile by taking an armful vertically down from the side or end, and not from the top; this insures the complete amalgamation of the several layers. While a little shoddy may be used advantageously in connection with

wool, care must be taken not to make the percentage of the cheapening element in the mix large enough to make the spinning of the yarn so difficult as to involve much extra expense; otherwise, the adulterated yarn will be found to cost almost as much as a pure woolen yarn, owing to the extra cost of manufacture due to lessened production and excessive waste.

**11. Mungo**, which is the worked-up waste of hard woolen goods such as overcoatings, beavers, meltons, and other hard-felted and milled goods, is mixed with new wool, as is also **extract**, or the recovered wool fibers of union goods composed of wool and cotton or other vegetable fibers. **Flocks**, or the short, fluffy woolen fibers occurring as the waste from nappers and shearing machines, are also used in connection with raw stock for producing mixtures, although they are more often added to the cloth during the finishing.

**12. Mixing Wool and Noils.**—These two materials are often blended. **Noils** are the short fibers removed from medium- or long-stapled wools by the combing process in the production of worsted yarns; they are pure wool and are sometimes used alone for the production of low-grade fabrics, but they do not possess the elasticity nor the natural wavy and lustrous nature of the original wool, although they make one of the best materials for mixing with wool. Noils should be carbonized before mixing, as they are removed by the comb in connection with burrs, chaff, straws, seeds, and other vegetable matter, the action of the comb being to remove all the impurities in a worsted card sliver as well as the short fibers. Noils and pure raw stock are mixed in the usual manner by being spread in alternate layers and then passed through the mixing picker.

**13. Mixing Wool and Cotton.**—The addition of cotton to wool in the manufacture of union fabrics is a common practice. Although the adulteration of woolen goods with cotton is not looked on with favor by many people, indeed is greatly deplored, there can be no doubt but that it is beneficial when used in suitable proportion in connection with



low classes of goods manufactured from inferior wool, since the cotton imparts to the fabric strength and wearing qualities that would otherwise be lacking. When cotton is introduced into a fabric it may either be in the form of separate threads of pure cotton or the materials may be mixed in the raw stock.

When cotton is mixed with wool it should first be run through the burr picker in order that it may be opened out and made fluffy, so that it will amalgamate well with the wool fiber and not form into individual bunches. It must be remembered that shoddy, mungo, extract, flocks, and noils are in reality pure wool, although more or less injured by the operations to which they have been subjected; but cotton is different in structure and requires different manipulation.

As has been said, the cotton must be picked and rendered open and lofty before being mixed with the wool, and it is all the better for being passed through a single carding process if a fine mix is to be made. The wool must be oiled and also picked before the mix is made; in no case should any oil be applied to the cotton. After the wool is well oiled and picked, the mix can be made. The stock should be laid out in successive layers of cotton and wool and afterwards run through the mixing picker a sufficient number of times to insure perfect amalgamation.

The process of making the so-called *vigogne yarn* is as follows: This yarn is sometimes composed of cotton and wool in about equal proportions, although often only from 3 to 10 per cent. of wool is used. The wool should be of quite fine fiber in order to blend well with the cotton and should also be well scoured, dried, burr-picked, and oiled. The cotton should be of good length of staple and should be run through the burr picker and a single carding process, which is performed on a woolen card. The wool may also be subjected to a single carding process if it is desired to make the best mix possible. The stock is then mixed, in the usual manner, by making a pile of the materials in alternate layers, taking it down vertically from the end, and subjecting it to two or three picking operations. It is, of course, only for fine work that so much trouble is taken as to card the stock. The ordinary method,

which gives excellent results, is to oil the wool and pick it, run the cotton through a burr picker, and then blend the wool and cotton in the right proportions and run the mixture through the mixing picker several times.

Cotton is used in connection with wool for low classes of worsteds, cassimeres, tweeds, flannels, etc. The cotton fiber should be as long as possible and the wool as fine as the grade of goods will allow, with a medium length of staple, and should also be sound, strong, and full of life and elasticity. As it is desired to have the goods resemble wool as nearly as possible, care should be taken to regulate the percentage of cotton according to the class of goods to be made, always using as little as possible to get goods out at the proper cost. On dress goods, flannels, and boys' suitings, from 50 to 75 per cent. cotton can be used. The cheapest possible lots of cotton are often selected, but it is better to have some consideration for the character of the wool. Where the wool is not very fine, a coarse, wiry cotton, as rough Peruvian or Brazilian, may be used with good results if the goods are dyed dark shades. American cotton, however, is generally used in American mills and is well suited for blending with wool. For mixing with fine wool, sea-island cotton, which has a long staple, is often used.

**14.** If a large percentage of white cotton is to be used and the yarn or cloth sold is white, the cotton should have a blue stain put on it in order to kill the chalky white appearance, which is never seen in pure woolen goods. In making a cotton-and-wool mix composed of 50 per cent. white and 50 per cent. black, one material should not be of one color, but preferably half of the wool should be dyed black and the other half left white; the same should be done with cotton and the results will be better than if the mix were made with black wool and white cotton, or vice versa. When using black cotton in wool mixes, the cotton should be dyed a blue black in order to overcome the rusty look of ordinary black cotton, which makes the goods look cheap.

In fancy mixes have the dyed cotton as fast as possible, especially if there is any white or light-colored ingredient in the mix. The reason for this is that unless the cotton dye is perfectly fast, it will *bleed*, or run, in finishing, staining the light-colored material in the mix. The cotton should for the same reason be fast-dyed in goods that have white or light-colored yarns in the pattern. In particular mixes, the stock is laid out in layers the second time, after being run once through the picker. In mixing only small proportions of cotton with wool it is not necessary to observe so many details; still the wool should be oiled separately, care being taken not to let the mix stand too long and thus allow the cotton to absorb the oil from the wool, and the materials should always be first picked separately.

If the mix is well made, the resulting fabric will be free from specks and the care put into the mixing will be well repaid. The cards must be in good condition for working cotton-and-wool mixtures, and the wool used must have good fulling properties, owing to the total absence of this characteristic in the cotton. If a large percentage of cotton is used, the cloth will have to be set finer in the loom in order to obtain the desired finished texture; as the more cotton used, the less the cloth will be shrunk in finishing. When cotton and wool are mixed and spun together, the cotton, if of long staple, has a tendency to go to the core of the thread and be entirely covered by the wool, which stays on the outside of the yarn.

**15. Mixing Wool and Silk.**—It is sometimes desirable to mix wool and silk waste in the production of fancy mixes. This is attended with some little difficulty, as the silk is extremely hard to card owing to its fluffy nature and its liability to become charged with static electricity if dry and subjected to friction.

When silk is blended with wool, it is desirable to have the silk the color of the largest ingredient in the mixture; if, for instance, the mixture is composed of 80 per cent. black and 20 per cent. white, the silk waste should be dyed black in

order to make the blend look even. The silk waste should first be carded before any attempt is made to introduce it into a mix.

It is important that both ingredients should be free from grease and gum. In oiling wool-and-silk mixes, the oil used should be of good quality and free from any acid, the wool being oiled separately as with cotton-and-wool blends. No oil should be applied to the silk. If there is quite a large percentage of silk in the mix and trouble from electricity or from an excessive amount of flyings is experienced in the carding, it may be necessary to dampen the silk with water before mixing. This can be done by spreading the silk in quite thin layers on the floor and covering it with wet bagging. If the bagging is wet enough and allowed to remain on the silk over night the stock will become sufficiently damp. If water is applied directly to the silk, the fibers are liable to mat.

---

#### SUMMARY

**16.** In general, when making a mix, the material should be spread quite thinly over a large area. As many layers as convenient should be made, and if one material enters into the combination only in a very small proportion, care should be taken to make first a temporary mix with this ingredient and a part of the one that forms the ground, or bulk, of the mix. Always break down the pile vertically from the end and run the stock through the mixing picker a sufficient number of times to insure a perfect blend.

If making a cotton-and-wool or wool-and-silk mix, oil the wool separately; otherwise, the cotton and silk will be difficult to mix and card. It is not wise to depend on the materials becoming mixed in the cards. They should be mixed first, so as not to make a mixing picker of the first breaker card. As great care should be taken with all-wool mixes as with wool and cotton in order to insure evenness and perfection throughout the operations following.

### FINDING THE COST OF MIXES

**17.** In mixing materials that vary in cost, it is often necessary to ascertain the cost of the blend per pound in order that the value of the resultant yarn or fabric may be estimated. Again, it may be necessary to obtain the percentage of a cheaper material required in a blend in order that the mix may be produced at a given value. Many other conditions also arise in connection with blending raw stock that require accurate figuring in order that the cost of the finished goods or their character may not be altered.

**18.** To find the cost per pound of a mix composed of two or more materials of different costs either in equal or unequal proportions:

**Rule.**—*Multiply the number of pounds of each material by its cost per pound, and divide the sum of the products thus obtained by the total number of pounds in the mix.*

**EXAMPLE.**—What is the cost per pound of a mix composed of 45 pounds of wool at 28 cents per pound, 25 pounds of shoddy at 14 cents per pound, and 10 pounds of cotton at 9 cents per pound?

**SOLUTION.**— 45 lb. of wool at 28 ct. per lb. will cost \$12.60; 25 lb. of shoddy at 14 ct. per lb. will cost \$3.50; 10 lb. of cotton at 9 ct. per lb. will cost \$.90. The total cost of the mix will be \$12.60 + \$3.50 + \$.90 = \$17. Since the total weight of the mix is 45 lb. + 25 lb. + 10 lb. or 80 lb., the cost per pound of the mix will be  $\$17 \div 80 = \$.2125$ , or  $21\frac{1}{4}$  ct. Ans.

**19.** To find the proportion of each ingredient in a mix composed of materials of different costs, in order that the resulting blend may have a definite cost per pound:

**Rule.**—*Arrange the respective values of each material in a column and place the desired cost of the mix at the left. Link these values together in pairs so that one element of each pair is greater and one less in value than the average cost. Find the difference between the average price and each element of a link*

and write it opposite the other element of the same link. Each of these differences has the same relation to their sum as the quantity of each material has to the mix.

**EXAMPLE 1.**—It is desired to mix enough cotton costing 10 cents per pound with wool costing 22 cents per pound so that the resultant mix will have a value of 18 cents per pound; what is the proportion of each ingredient necessary?

**SOLUTION.**—The difference between 18 and 22 is 4, which is placed opposite the 10, to which the 22 is linked, while the difference between 18 and 10 is 8, which is placed opposite the 22, to which the 10 is linked. From this it will be seen that each 12 lb. of mix should contain 4 lb. of cotton and 8 lb. of wool. Ans.

**PROOF.**—This example can be proved, by applying the rule in Art. 18, as follows: 8 pounds of wool at 22 cents per pound will cost \$1.76; 4 pounds of cotton at 10 cents per pound will cost \$.40. The total cost of the mix will be \$1.76 + \$.40 = \$2.16. The cost per pound of the mix will be \$2.16 ÷ 12 = \$.18, or 18 cents.

The rule in Art. 19 can be applied in case more than two ingredients enter into the mix, but care must always be taken to link together a higher and a lower value than the desired average.

**EXAMPLE 2.**—Suppose that four materials, A at 6 cents per pound, B at 10 cents per pound, C at 16 cents per pound, and D at 20 cents per pound are to be blended; what proportion of each will be necessary so that the resulting mix will have a value of 14 cents per pound?

**SOLUTION 1.**—The difference between 20 and 14 is 6, which is placed opposite 10, to which 20 is linked; the difference between 16 and 14 is 2, which is placed opposite 6, to which 16 is linked; the difference between 10 and 14 is 4, which is placed opposite 20, to which 10 is linked; the difference between 6 and 14 is 8, which is placed opposite 16, to which 6 is linked. From this it will be seen that each 20 lb. of the mix should contain 2 lb. of A, 6 lb. of B, 8 lb. of C, and 4 lb. of D. Ans.

**PROOF.**—This example can be proved, by applying the rule in Art. 18, as follows: 2 pounds of A at 6 cents per pound will cost 12 cents; 6 pounds of B at 10 cents per pound

will cost 60 cents; 8 pounds of C at 16 cents per pound will cost 128 cents; and 4 pounds of D at 20 cents per pound will cost 80 cents. The total cost of the mix will be  $12 + 60 + 128 + 80 = 280$  cents. The cost per pound of the mix will be  $280 \div 20 = 14$  cents.

In a case like this it should be noted that by linking different quantities together, taking care to link a higher and a lower value than the required average, the proportions of the different ingredients may be varied and at the same time the correct average cost obtained. To illustrate, take the same example again.

SOLUTION 2.—The difference between 20 and 14 is 6, which is placed opposite 6, to which 20 is linked; the difference between 16 and 14 is 2, which is placed opposite 10, to which 16 is linked; the difference between 10 and 14 is 4, which is placed after 16, to which 10 is linked; the difference between 6 and 14 is 8, which is placed after 20, to which 6 is linked. From this it will be seen that each 20 lb. of the mix should contain 6 lb. of A, 2 lb. of B, 4 lb. of C, and 8 lb. of D. Ans.

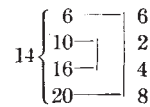

PROOF.—This example can be proved by applying the rule in Art. 18. 6 pounds of A at 6 cents per pound will cost 36 cents; 2 pounds of B at 10 cents per pound will cost 20 cents; 4 pounds of C at 16 cents per pound will cost 64 cents; 8 pounds of D at 20 cents per pound will cost 160 cents. The total cost of the mix will be  $36 + 20 + 64 + 160 = 280$  cents. The cost per pound of the mix will be  $280 \div 20 = 14$  cents.

In the examples given two of the materials cost more and two less than the required cost of the blend; sometimes, however, only one of the materials may be more or less than the average cost. In a case like this all the other values are linked to this one and the differences added together.

EXAMPLE 3.—Four materials, A at 8 cents per pound, B at 10 cents per pound, C at 15 cents per pound, and D at 22 cents per pound are to be mixed; in what proportion must each enter into the blend in order that the average cost shall be 17 cents?

SOLUTION.—The sum of the differences between the values of A, B, and C and 17 gives the proportion of D that enters into the mix, or 18 lb. in every 33 lb. of the mix, while the difference between 22 and 17, or 5, gives the proportion of each of the other materials.

$$17 \left\{ \begin{array}{l} 8 \\ 10 \\ 15 \\ 22 \end{array} \right. \begin{array}{l} 5 \\ 5 \\ 5 \\ 9 + 7 + 2 = 18 \end{array}$$

After having found, by the preceding rules, the amounts in which each material enters into the blend, it is a comparatively simple matter to find by proportion the amount of each required in any given number of pounds of a mix.

### MIXING PICKERS

20. After the materials composing a mix have been carefully spread in layers on the floor of the picker room, the next operation is to pass the stock through a machine designed to blend and intermingle the various components in such a manner that a homogeneous mix is obtained. In America, the machine most commonly used for this purpose is the **mixing picker**; while in Europe, and to a small extent in America, the same results are obtained with a *Fearnaught*, a machine totally different in principle from the mixing picker. Another object of the mixing picker is to open out the wool so that it will be in suitable condition for feeding to the cards.

The principle on which the mixing picker operates is that of opening the wool and intermingling the fibers by means of a rapidly rotating cylinder armed with strong teeth curved forwards in the direction in which the cylinder rotates.

### DAVIS & FURBER MIXING PICKER

21. **Construction.**—The main, or picking, cylinder of this machine, as shown in Fig. 2, consists of six wrought-iron lags  $l_1$  mounted on three or four spiders  $l$ , according to the width of the machine. The lags are firmly bolted to the inside spiders and, being fitted into slots in the two outside



ones, are firmly secured by means of heavy wrought-iron hoops that are shrunk over their ends. The teeth  $l_4$  for

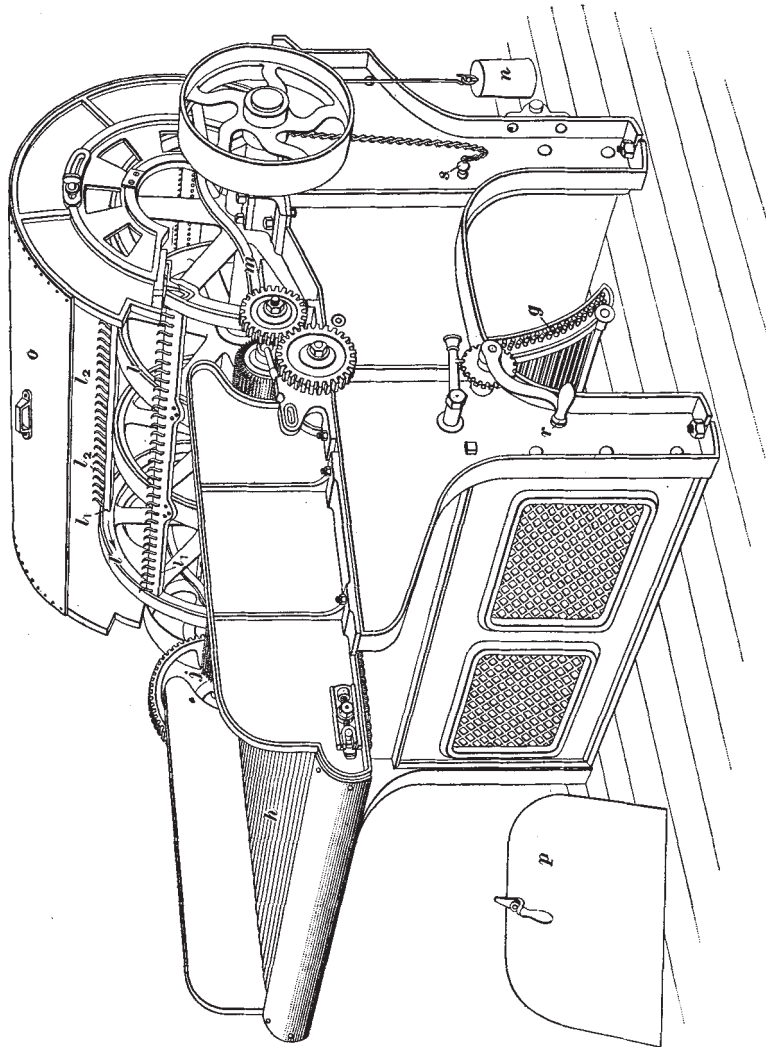

FIG. 2

opening the stock are of cast steel firmly screwed into the lags of the cylinder and fastened by means of setscrews, so

as to preserve the alinement of the points of the teeth by preventing them from turning, as they would be liable to do in course of time if simply screwed in. Teeth fastened in this manner can readily be removed if broken and new teeth substituted. The shape of the teeth is such that they will engage with and open the stock without injuring or breaking the staple.

The picking cylinder works in connection with the grate *g*, Figs. 2 and 6, in a manner similar to that employed in burr pickers and dusters, and a considerable amount of dirt and other foreign matter that has escaped the previous operations is allowed to drop through this grate into the space underneath that is provided for its reception. The grate in this machine is constructed of iron bars in such a manner as to expose the least amount of surface possible for the accumulation of grease or gummy deposits, which, of course, are undesirable, as they tend to clog the grate. The grate is hinged at one end and may be lowered or raised by means of the crank *r*, Fig. 2, conveniently located at one side of the machine. This crank operates a pinion gear *g*<sub>1</sub>, Fig. 6, which by means of a rack *g*<sub>2</sub> imparts movement to the grate. This arrangement greatly facilitates the operation of cleaning the grate. When raised, the grate is locked in place by means of two pins *s*, Fig. 2, on which it rests, one on each side of the machine. The grate is shown lowered from the picking cylinder in Fig. 2. The refuse is removed from underneath the machine at either side, for which purpose removable panels *p* are provided, the one shown in Fig. 2 being removed from the machine.

The feeding arrangement on this machine differs from those on other machines. The stock is not fed by a pair of feed-rolls but by a single roll *j* working in conjunction with a concave dish, or shell, *k*, the arrangement being sometimes known as the shell-and-pin feed. (See Fig. 6.) The curve of the dish is the same as that of the circumference of the feed-roll. The stock is taken by the feed-roll and, being held against it by the dish, is delivered to the cylinder, which revolves close to the edge of the dish. While this

method of feeding is sometimes advocated for the reason that the stock is better opened in being taken by the cylinder from the edge of the dish, it is not so good as a pair of cockspur feed-rolls, because the single roll is liable to choke up while in operation. In order to remedy this, however, the pins are set into the roll at a slight angle, so that the action of the picker cylinder will tend to strip the feed-roll. This machine is made with a pair of cockspur feed-rolls if so desired.

Allowance is made for a vertical motion of the feed-roll, which is controlled by two levers *m*, Fig. 2, one on each side of the machine. These levers have heavy weights *n* suspended from their extremities and are so arranged as to bear on the journals of the feed-roll. This allows any bunches in the stock or inequalities of feeding to raise the feed-roll and prevent the machine from being strained or broken. The feed-apron *h* is of the usual type, composed of wooden slats fixed on endless traveling belts, a means being provided for taking up the slack as the apron stretches from wear. Sometimes, however, the slats of the feed-apron are made of iron, the object being to make the machine fireproof as far as possible, since a machine of this description will become very greasy and there is danger of the swiftly rotating cylinder striking fire and starting a conflagration.

**22. Operation.**—In operation, the wool or other stock is fed either by hand or by a self-feed, as shown in Fig. 6, on a traveling feed-apron *h*, which delivers it to the straight-toothed feed-roll *j*. The stock is held against this roll by the stationary concave dish and the roll in rotating carries the wool to the main cylinder, which is armed with strong curved teeth about  $2\frac{1}{2}$  or 3 inches long, which comb out the wool as it is held on the edge of the dish by the feed-roll. The cylinder revolves down past the feed-roll and makes from 700 to 1,000 revolutions per minute, according to the width of the machine.

As the wool is taken from the feed-roll by the cylinder it is swept down over the grate *g* and a great deal of the

foreign matter remaining in the stock beaten out and allowed to fall through the grate, while the picked stock is carried by the current of air generated by the rapidly rotating cylinder through the outlet  $m_1$  to the gauze room.

**23.** The machine described is made in sizes from 24 inches to 48 inches wide and requires from 3 to 8 horsepower for driving. The larger sizes, which require more power, are made with a pulley on each side allowing two belts to be used for driving. This, of course, requires a countershaft. The diameters of the pulleys are from 10 inches to 14 inches, according to the width of the machine. The capacity of the largest machine is from 2,000 to 2,400 pounds per hour, the narrower machines producing less in proportion to their width.

---

#### ATLAS MIXING PICKER

**24. Construction.**—The mixing picker shown in Fig. 3, although similar in general principle, is somewhat different in a few points from the machine just described. The object is the same as that of all other mixing pickers; namely, to open the stock for the cards and also to mix thoroughly and blend any mixtures of colors, qualities, or materials that may be passed through. The only wood used in the construction of the picker is for the feed-apron slats, and the machine is therefore practically fireproof and especially adapted for the use of oiled stock.

The feed-rolls of this machine are one of its distinctive features and instead of a single roll or a single pair of rolls there are two pairs  $j_1, j_2$ , the second pair running one-third faster than the other pair; this makes what is known as a *draft* between the two sets of rolls. In textile machinery when fibers are drawn between two or more pairs of rotating rolls and one pair of the rolls rotates faster than the other, a draft is said to be produced. The amount of draft where the two pairs of rolls have the same diameter is found by dividing the speed of the quicker rolls by the speed of the slower

ones. Thus, if one pair of rolls makes 14 revolutions per minute, and another pair 21 revolutions per minute, both being the same diameter, the draft is  $\frac{21}{14} = 1.5$ .

**25. Driving.**—The driving of the feed-rolls is as follows: A pulley on the picker-cylinder shaft on the left side of the machine drives a pulley on the first auxiliary shaft, which is located at the rear of the machine. This drive is not shown in Fig. 3, being on the opposite side of the machine. A pulley on this first auxiliary shaft drives a pulley *t* on the second auxiliary shaft located under the feed-

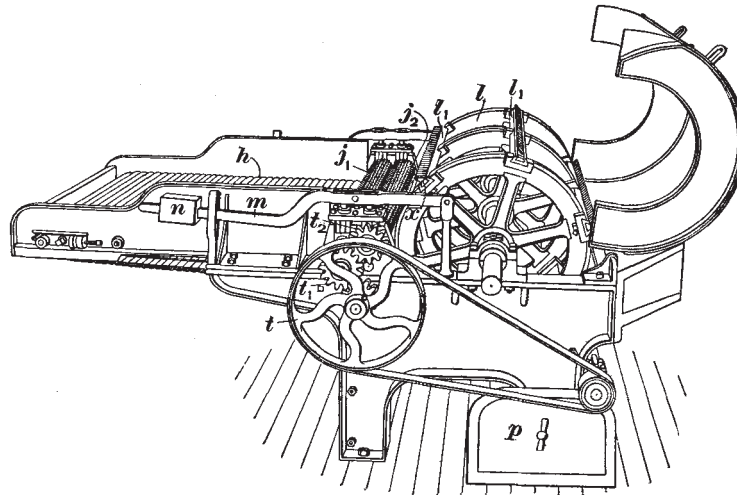

FIG. 3

rolls. On the right-hand side of the machine, a gear on the second auxiliary shaft drives a gear *t*<sub>1</sub> on the first bottom feed-roll shaft, which in turn drives a gear *t*<sub>2</sub> on the rear top feed-roll shaft. On the left-hand side, but not shown in Fig. 3, a gear on the end of the second auxiliary shaft drives a gear on the rear bottom feed-roll shaft, which in turn drives a gear on the first top feed-roll shaft.

The feed-apron *h* is driven by means of a gear on the bottom feed-roll shaft on the opposite side of the machine, from that shown in Fig. 3 which drives a gear on the

apron-roll shaft through a small intermediate gear on a stud. There is about  $\frac{1}{2}$  inch space between the apron and the feed-roll, which allows heavy foreign materials to drop to the floor so as not to enter the picker. Both the front and the rear top feed-rolls are controlled by levers  $m$ , one on each side of the machine, on which weights  $n$  are fastened; these give the rolls a little play, or up-and-down motion, to allow for bunches in the stock and for irregular feeding.

The picker cylinder of this machine is composed of three iron spiders  $l$  fastened on the main shaft, to which are dovetailed six steel lags  $l_1$ . Flat steel teeth are dovetailed with the lags, doing away with setscrews for fastening them. The main shaft is equipped with tight and loose pulleys, or with a tight pulley on each side for double driving, which is advisable with the wider machines.

The grate under the picker cylinder may be drawn out on a slide for cleaning. The space under the grate is cleaned from either side by the removal of panels  $p$ .

**26. Operation.**—In operation, the stock is fed on the slatted apron  $h$  either by hand or by an automatic feed and is delivered to the first pair of feed-rolls  $j_1$ , which holds the wool while the second set  $j_2$ , running one-third faster, combs and opens it out.

The advantage of a double set of feed-rolls with a draft between them is that the stock is more thoroughly opened, straightened, and mixed than by the ordinary picker with a single pair of rolls; and it is also impossible for bunches of stock to pass directly to the cylinder and the fibers to become broken by being opened too quickly, as the first pair of rolls holds the stock while the second pair, running faster, gradually opens it out and pulls it apart. This insures a thorough opening and mixing of the stock with very little liability of injury to the fiber. The stock is next delivered to the picker cylinder, which revolves downwards and beats the wool over the grate, finally delivering it through a trunk to the gauze room.

**POINTS IN MANAGEMENT**

**27.** Pickers require frequent cleaning and should never be allowed to become clogged with gummy grease, as will happen if they are not cleaned between different lots of stock operated on. The cylinder of the picker should be examined frequently for loose or broken teeth, which should be tightened or replaced at once since they reduce the efficiency of the machine; the picker-cylinder bearings should be oiled at least twice a day, as they are very apt to heat, owing to the high speed and the weight of the cylinder. A 36-inch picker may be run at 1,000 revolutions per minute, but the wider machines, as for instance, the 48-inch, should not make more than 800 revolutions per minute. These speeds may be regarded as maximum speeds, and it will be found that a picker will give longer and more satisfactory service if driven somewhat slower. For the best results it will be found advantageous to feed the picker somewhat light rather than to have bunches of stock to open out on the card.

The heavy cylinder of a picker armed with strong, sharp teeth and rotating with great velocity is a source of great danger, and many accidents occur owing to carelessness and neglect of even ordinary precaution. A good rule to follow is never to remove the bonnet or to take out the grate while the cylinder is in motion. When cleaning the cylinder or the grate underneath, the bonnet may be lifted and a stout stick or an iron bar thrust through the cylinder to prevent any one from unwittingly starting the machine while it is being cleaned.

---

**FEARNAUGHT**

**28.** While this machine is used for the same purposes as a mixing picker, it is entirely different, both in principle and construction. The principle of the Fearnought may be considered as that of opening the wool by means of a large rotating cylinder filled with cockspur teeth, which work in conjunction with similar teeth placed in smaller rolls arranged over the large cylinder. The combined action of the

cylinder and smaller rolls, which are known as workers, is to separate all bunches of wool and to intermix the fibers thoroughly.

**29. Construction.**—While wood enters to a larger extent in the construction of a Fearnought than of a mixing picker, this is not objectionable, since the slower speeds of the parts of this machine render them less liable to cause fire than the rapidly rotating cylinder of a mixing picker. As shown in Fig. 4, the feed-apron *h* is of the usual construction; the iron feed-rolls *j* are filled with intersecting cockspur teeth and are self-cleaning. The main cylinder *l* and

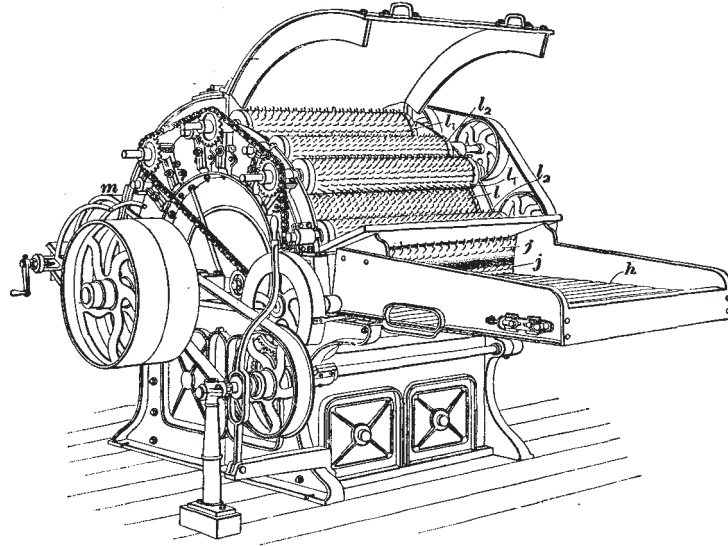

FIG. 4

workers *l*<sub>1</sub> are of wood and are filled with cockspur teeth forged from square steel rods and firmly driven into the wood. The machine is usually constructed with four workers. In order to keep the workers clear of wool, a stripping roll, or stripper, *l*<sub>2</sub> works in conjunction with each worker. The strippers are filled with teeth similar to those in the main cylinder and workers except that they are straight. Owing to the strain of opening the wool, the



workers must be driven with a chain, but the strippers, as they are subjected to but little strain, may be driven with a belt. There is a beater, or fan doffer, *m* (similar in construction to the beater shown at *f*, Fig. 6) at the rear of the machine. This takes the stock from the main cylinder and throws it out of the machine.

**30. Operation.**—In operation the stock is spread evenly on the traveling feed-apron and is taken by the cockspur feed-rolls, which hold it as it is combed out by the main cylinder. The cylinder then brings the stock under the action of the workers, and the passing of the teeth on these rolls between those on the cylinder results in the wool being thoroughly opened and combed out. The strippers take the stock from the workers and pass it back to the main cylinder, which besides opening out the wool in conjunction with each of the workers acts as a carrier, conveying the stock from the feed-rolls to the fan doffer. The doffer takes the stock from the main cylinder and by virtue of the current of air that it generates, delivers it through a trunk to the gauze room.

**31.** The Fearnought is an excellent machine for opening and mixing wool, doing its work with no perceptible injury to the fiber. Its gentle action is due to the principle of its construction and the comparatively slow speeds of its moving parts.

A Fearnought with a cylinder 36 inches in diameter should make about 225 revolutions per minute; one having a cylinder 48 inches in diameter should make 175 revolutions per minute; while a cylinder 55 inches in diameter should not have a speed of more than 100 revolutions per minute. Its capacity varies, according to its size, from 800 to 1,500 pounds of wool per hour. The machine is built in three widths—36-inch, 40-inch, and 48-inch—having cylinders 36 inches, 48 inches, and 55 inches in diameter, respectively. The 48-inch machine is used for carpet wools and long worsted stock.

### THE BRAMWELL AUTOMATIC PICKER FEED

32. The object of automatic, or self-feeding, devices is to deliver the stock to other machines evenly and uniformly and at the same time to allow the operator to care for a maximum number of machines with a minimum amount of

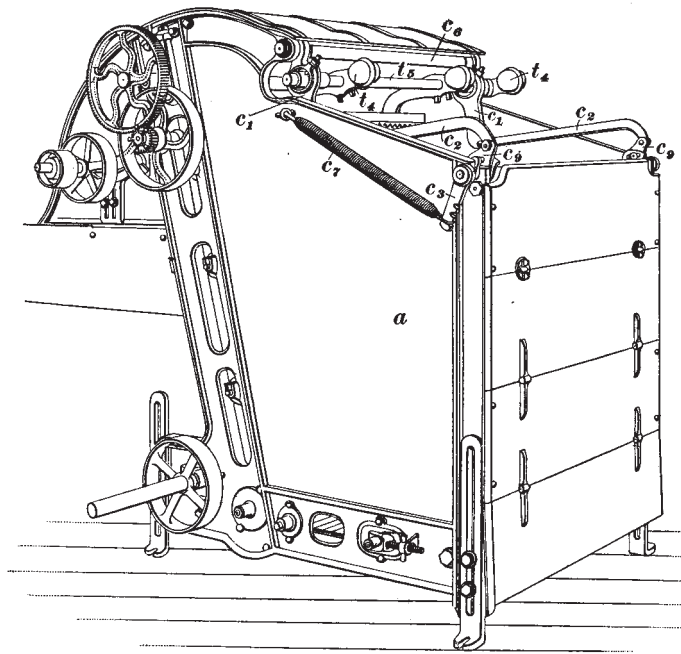

FIG. 5

labor. The general features of the Bramwell self-feed as adapted for feeding mixing pickers, burr pickers, dusters, and similar machines are shown in Figs. 5 and 6, the latter being a sectional view and showing the machine as connected with a mixing picker.

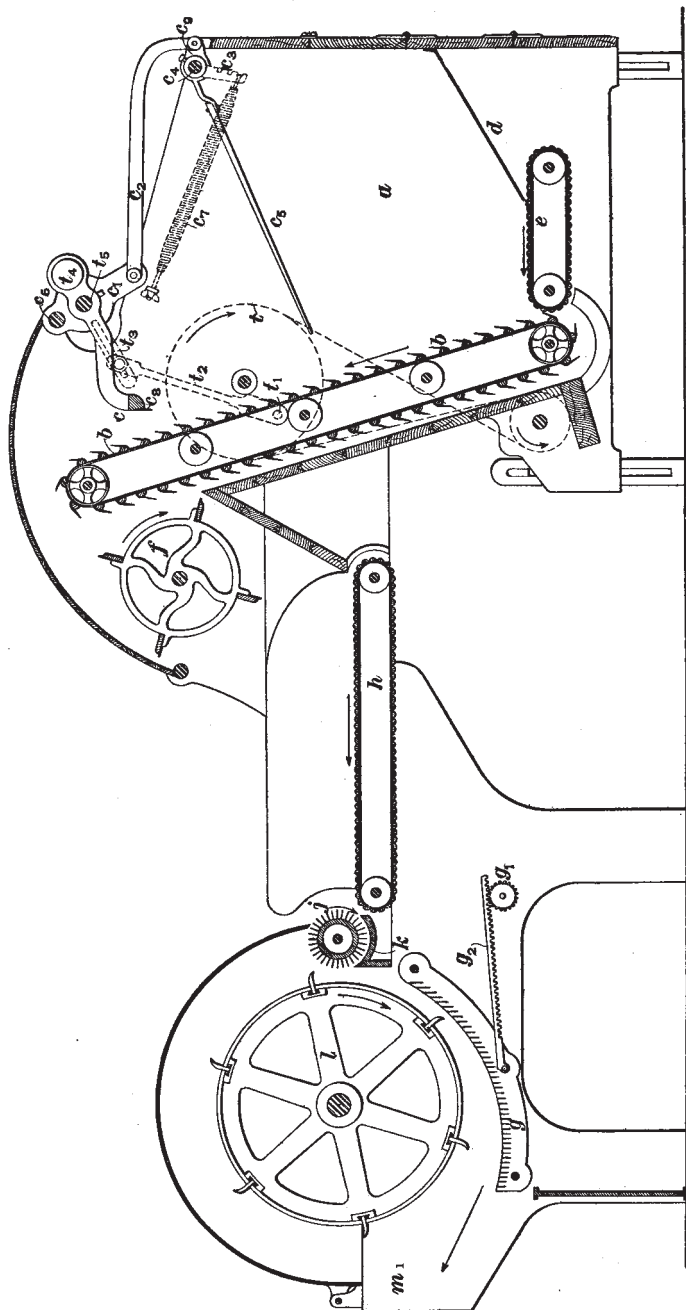

FIG. 6

**33. Construction.**—As shown at Fig. 6, the machine consists primarily of a large feed-box, or hopper *a*, which the operator keeps supplied with stock. At the rear of the hopper is an endless apron *b*, called a lifting, or elevating, apron. This apron, which travels in the direction indicated by the arrow, is provided with a series of slats fitted with sharp spikes about an inch in length and inclined forwards in the direction in which the apron is traveling. The apron extracts the stock from the hopper and carries it to a beater *f*. This beater strikes the wool from the apron and deposits it evenly on the feed-apron of the machine to which the feeding machine is attached. The amount of stock carried by the lifting apron is regulated by an oscillating comb *c* that strikes off all large bunches of wool that the apron extracts from the hopper, thus rendering the apron more evenly loaded and the feed more regular. The greater part of the machine is of iron, but the rear end of the hopper is boarded up, provision being made by means of hinges and iron buttons for removing the boards, so that the hopper may be brushed out when the machine is cleaned. At the bottom of the hopper there is a traveling apron *e* for the purpose of keeping the stock in the hopper in contact with the lifting apron at all times. Both this apron and the lifting apron are constructed of hardwood, half-round slats riveted to leather belts. There are adjustments on the wooden rolls on which these aprons run by means of which the aprons may be tightened in case they grow slack from wear or stretching. In the lower part of the hopper there is also a tin slide *d*, placed at an angle of about 30° with the bottom of the hopper and sloping downwards toward the lifting apron. This slide causes the wool to move forwards to the traveling apron, so that when the machine is allowed to run empty no stock will remain in the hopper. The beater is constructed with four blades having strips of leather attached; these sweep the stock from the spikes in the elevating apron without in any way injuring the wool. There are adjustments on the bearings of the beater by means of which it may be set nearer to or farther from the lifting apron as occasion demands.

The self-feed is usually driven from the main shaft of the mixing picker, when connected to that machine, with a cross-belt and is provided with tight and loose pulleys on the shaft at the bottom of the machine. The driven pulleys are not shown in Fig. 5. There is a belt shipper so arranged that the feed may be stopped from either side of the machine. The beater is driven by a cross-belt from the lower, or main, shaft of the feeder. The lifting apron is driven from a pulley on the main shaft, which drives a pulley on a stud with a crossed belt. Fastened to this pulley is a small gear, which is the change gear for the speed of the aprons, an increase of its size giving a greater speed to the lifting and traveling aprons and a heavier feed to the mixing picker. The change gear, as shown at Fig. 5, drives a large gear on the shaft of the top lifting-apron roll, which carries the apron. On the opposite side of the machine the traveling apron is driven from the shaft of the bottom lifting-apron roll by means of a short train of gears connecting with the front roll of the traveling apron.

The oscillating comb  $c$ , Fig. 6, is driven from a pulley on the main shaft of the machine, which drives the pulley  $l$  on a stud; on this pulley there is a crankpin  $l_1$  to which a connecting rod  $l_2$  is attached; the latter is also connected with an arm  $l_3$  attached to the comb shaft  $l_4$ . There is a slot in this arm, which admits of changing the position of the connecting-rod, thus varying the throw of the comb. Weights  $l_4$  are attached to the comb in order to balance it, so that its motion may be more regular. The comb is provided with triangular teeth  $c_s$ , which comb off the excess of stock that is extracted from the hopper by the lifting apron.

**34. Comb Regulating Device.**—There is a device for regulating the proximity of the comb to the lifting apron by means of which, if the wool is nearly exhausted from the hopper, the comb is moved from the apron and less wool struck from the lifting apron. This makes the feed uniform whether the hopper is full or nearly empty. If such an arrangement were not provided, a large amount of the wool

would be passed forwards when the hopper was full and a small amount when nearly empty.

The principal parts involved in this device are suspended from a fixed shaft  $c_6$ , Fig. 6, by means of arms  $c_1$ , one on each side of the machine. These arms, with the shaft  $t_5$ , can be pushed nearer to the lifting apron, thus reducing the distance between the comb and the apron, or drawn farther away, thus increasing the distance, by means of the horizontal curved arms  $c_2$ , of which there are two (one on each side of the machine) attached to the lower ends of the arms  $c_1$ .

The comb arms  $c$  are attached to the central shaft  $t_5$ , to which is also attached the arm  $t_3$  on the outside of the machine, which receives an oscillating movement from the pulley and crank arrangement shown by the dotted lines. This oscillating motion of the comb, however, has nothing to do with regulating its distance from the lifting apron, which is governed by means of a comb regulator, or finger rack,  $c_3$ . The normal position of the rack is very nearly at right angles with the lifting apron when the hopper is empty, it being held in that position by means of two springs attached to short arms  $c_5$  fastened to its shaft  $c_4$ , one on each side of the machine, the spring shown being marked  $c_7$ . The tension of these springs may be regulated by means of thumbscrews. When the hopper is filled, the wool is thrown on the top of the rack, pressing it downwards until it is forced against the back of the hopper into an almost vertical position. The rack is attached to the shaft  $c_4$  and, by means of short arms  $c_6$ , is pinned to the curved ends of the rods  $c_2$  that operate the ends of arms  $c_1$ .

As the lifting apron extracts the stock, the amount remaining in the hopper will be diminished and, consequently, the pull of the springs  $c_7$  will raise the finger rack as fast as the weight of the stock in the hopper is decreased. The motion thus imparted to the shaft  $c_4$  will move the levers  $c_6$  backwards and, by means of the connecting-rods  $c_2$ , the levers  $c_1$  will be drawn in the same direction. Since the comb is supported by arms attached to the shaft  $t_5$ , which is carried by the levers  $c_1$  fulcrumed on the fixed shaft  $c_6$ ,

the upward motion of the finger rack will draw the comb from the lifting apron, which will result in less wool being struck from the apron. When the hopper is refilled, the rack will be pressed down again by the weight of the stock, thus moving the comb nearer to the lifting apron so that there will be no increase in the amount of stock passed forwards to the picker in consequence of the hopper being full. By this means the feed is kept uniform without regard to the amount of stock in the hopper. The comb should not be set too close to the lifting apron and the latter should be allowed to carry a fairly heavy feed, except on fine stock.

**35. Operation.**—The self-feed and mixing picker shown in Fig. 6 operate as follows: The hopper *a* of the self-feed being supplied with wool, the spikes on the lifting apron *b* extract an amount of stock in excess of what is required. This excess of stock being struck off and the feed kept uniform as explained, the apron conveys the wool to the beater *f*, which sweeps off the stock and drops it on the feed-apron *h* of the picker. The stock is then delivered to the feed-roll *j*, which, working in conjunction with the concave dish *k*, passes the wool to the picker cylinder *l*, the stock being finally passed in an open and lofty condition to the gauze room through the trunk at *m*.

The feed requires very little extra power, possibly 2 horsepower for the largest machine when feeding heavy. With smaller machines and lighter feeds, the horsepower required will be correspondingly reduced.

# WOOL MIXING

## EXAMINATION QUESTIONS

- (1) What is mixing and for what purpose is it resorted to?
- (2) State, fully, the method of laying out a mix.
- (3) Make a sketch of a mix containing three materials or colors, the proportion of the ingredients being 50, 25, and 25 per cent.
- (4) What precaution must be observed in taking the blended stock from the pile to pass it through the mixing picker? Why?
- (5) If a mix containing only 10 per cent. of one color is to be made, what precaution should be taken in order to insure the uniform distribution of this color throughout the batch?
- (6) In white cotton-and-wool mixes that contain a large percentage of cotton, what remedy is there for the chalky white appearance of the resulting yarn?
- (7) If an Oxford mix containing only 3 per cent. of white stock is to be made, what precaution should be taken in regard to the white stock in order to insure its uniform distribution?
- (8) What is the effect of imperfect mixing?
- (9) What is the cost per pound of a mix composed of 70 pounds of wool at 26 cents per pound, 18 pounds of shoddy at 11 cents per pound, and 12 pounds of cotton at  $8\frac{1}{2}$  cents per pound? Ans.  $21\frac{1}{5}$  ct.



(10) If a mix is to be made containing 50 per cent. of black and 50 per cent. of white stock and it is to be composed of wool and cotton in equal proportions, should all black cotton or all black wool be used?

(11) (a) How many pounds of each of the following materials will be required to make a mix of 440 pounds, costing 15 cents per pound: A at 23 cents, B at 19 cents, C at 11 cents, and D at 9 cents per pound? (b) Vary the proportions of the materials, still keeping the average cost at 15 cents per pound, and state how many pounds of each will then be required to make the mix.

$$\text{Ans. (a)} \begin{cases} A, 80 \text{ lb.} \\ B, 120 \text{ lb.} \\ C, 160 \text{ lb.} \\ D, 80 \text{ lb.} \end{cases} \quad (b) \begin{cases} A, 120 \text{ lb.} \\ B, 80 \text{ lb.} \\ C, 80 \text{ lb.} \\ D, 160 \text{ lb.} \end{cases}$$

(12) Describe the operation of a mixing picker.

(13) What peculiar arrangement is there for feeding the stock to the main cylinder on the Davis & Furber picker?

(14) What is the object of allowing a slight vertical motion to the top feed-rolls of mixing pickers?

(15) Explain the drafting action of the feed-rolls on the Atlas picker.

(16) Describe the Fearnought and state how its action compares with that of the mixing picker.

(17) Three materials are to be mixed: A costing 28 cents, B 18 cents, and C 13 cents per pound; how many pounds of each will be required to make a mix of 500 pounds costing 20 cents per pound?

$$\text{Ans.} \begin{cases} A, 180 \text{ lb.} \\ B, 160 \text{ lb.} \\ C, 160 \text{ lb.} \end{cases}$$

(18) A mill has 520 pounds of wool on hand worth 20 cents per pound; how much cotton at 8 cents per pound must be purchased to mix with this wool in such a proportion that the mixture will be worth 16 cents per pound?

$$\text{Ans. } 260 \text{ lb.}$$

(19) What are the best methods to employ in making cotton and wool mixes?

(20) Describe the comb mechanism that is used on the Bramwell picker feed to render the feeding of the stock uniform.