

# PLAIN LOOMS

Serial 491

Edition 1

## INTRODUCTION

**1. Evolution of the Loom.**—The name **loom** is generally applied to any machine that produces a woven fabric as distinct from a knitted fabric. Weaving is one of the oldest of the textile arts, and for the production of ordinary fabrics is a comparatively simple process. It was practiced wholly by hand until about the end of the 18th century, when an entire change took place. From the combined efforts of inventors there was then evolved a loom of such construction that almost the whole operation of weaving could be performed by power. In all essential details this machine was constructed on the same principles as the looms that have been in use throughout the 19th century.

During this period countless efforts have been made to improve the loom, and many of these have resulted in changes. Each attempt at betterment, however, has usually been confined to some one motion or part of the loom, effecting improvements merely in the details of construction and operation; until 10 years ago very few great improvements had been made in the plain power loom, and at that time a new plain loom did not differ very much in general appearance and construction from a loom built a generation previous. During the last decade, however, there has been a strong tendency toward improving the plain loom by making it more automatic, and undoubtedly the next 10 years will see still greater changes, and weaving a decade hence will be a very different art from what it was 10 years ago.

*For notice of copyright, see page immediately following the title page*

The English loom differs considerably from the American loom, as in Europe the same attention has not been given to the development of weaving machinery as has been done in America; consequently, in many respects (though not all) the American loom is superior to its English forerunner, especially with regard to labor-saving devices.

The object of the loom is to interlace yarns in such a way as to form a cloth or fabric. Instead of threads, filaments or strips may be used, and the fabric may be of all kinds, from the finest muslin to the heaviest bagging.

**2. Principle of Construction.**—The principle on which the loom is constructed is that of manipulating two series of yarns—the warp and the filling—so that the warp will be slowly drawn through the loom, the warp threads being separated frequently, and the filling, which is contained in a **shuttle**, thrown through the spaces formed; the warp threads are crossed after each pick of filling is inserted, so as to bind the latter in place.

In order to interlace the yarns, it is customary to prepare them in two forms known, respectively, as *warp* and *filling*. By the **warp** is meant that system of threads which is placed on what is called a **loom beam**, and which consists of a sheet of ends wound repeatedly around a roll and stretched from back to front of the loom.

The name **filling** is applied to a series of threads that run across the fabric and are interlaced with the warp when the warp ends are raised or depressed. In other words, the warp is stretched from back to front of the loom and, when the cloth is woven, forms the threads that run lengthwise, while the filling is passed from side to side of the loom and forms the yarn in the fabric that runs crosswise.

**3. Operation of the Loom.**—It will be seen that, in order to make cloth, some of the warp threads must be raised and others lowered to produce the space through which the filling can be passed. This space is called a **shed**, and through it the filling is thrown from side to side.

The throwing across of the filling is known as **picking**.

The shuttle, in being thrown from one side of the loom to the other, leaves the filling some distance from the edge, or fell, of the cloth. It is therefore necessary to push it forwards to the cloth, that is, to the picks that have previously been put in and that help to form the fabric. This process is known as **beating up** and completes the round of operations necessary to produce cloth.

The common loom, as used today, in addition to performing the operations of shedding, picking, and beating up, has many parts that must perform certain other operations in order to render it automatic. For example, **take-up motions** are applied to draw the interwoven warp and filling forwards after it has become cloth; **let-off motions** are used to release the warp at the desired rate of speed; **automatic stop-motions** are provided to cause the loom to cease operating when the filling breaks, and in some cases when a single end of the warp breaks; **temples** are provided to extend the cloth sidewise; all of these attachments are found on what is called a *plain loom*.

The fact must not be forgotten that, notwithstanding the use of these necessary attachments, the actual operation of weaving is simply a continuous repetition of shedding, picking, and beating up, though these three motions may be obtained in different ways, and auxiliary motions for producing other effects may be added. In order that the elementary principles of weaving shall be thoroughly understood, the essential parts of a plain loom will be pointed out briefly, and afterwards the object and operation of each part will be fully described.

---

#### PARTS OF A PLAIN LOOM

4. Fig. 1 is a front view of a **plain loom**, while Fig. 2 gives a view of the back of the same loom. In pointing out the different parts of this loom, the American terms most commonly used will be given. The reference letters used in Figs. 1 and 2 correspond, so that references to one figure apply equally to the other.

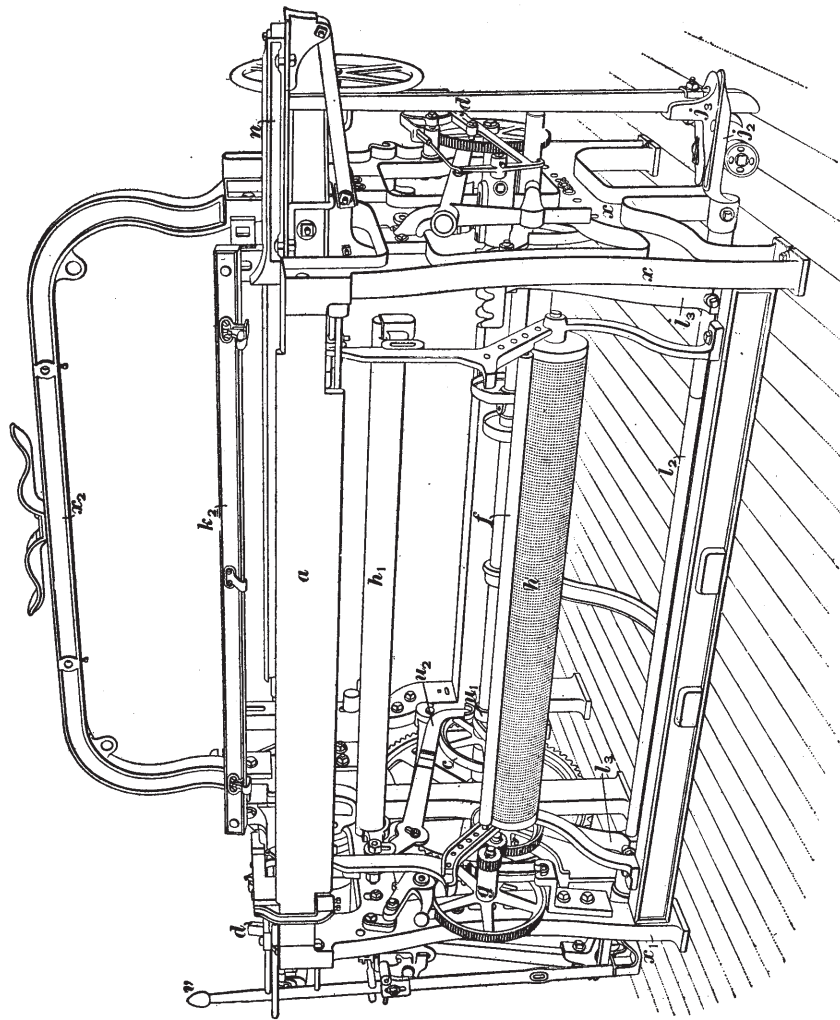

FIG. 1



**5. Setting Up the Parts.**—The first parts of a loom to be set up are the sides marked  $x$  and  $x_1$ . These sides are connected by girts and by an arch marked  $x_2$ ; also, by other parts, all tending to form a strong and suitable support for the different mechanisms of the loom.

Extending from one side of the loom to the other is the crank-shaft  $l_1$ . The tight-and-loose pulleys  $w, w_1$  are fastened on one end of this shaft. These pulleys are driven by a belt, which, in turn, is driven by a pulley on either a line or countershaft. This belt runs through a belt fork, and may be shipped from one pulley to the other by means of the shipper handle  $v$ .

On this same end of the crank-shaft is also fastened a gear  $l_4$ , which engages with and drives another gear  $l_5$ , of exactly double the number of teeth of the gear on the crank-shaft. The gear  $l_5$  is fastened to a shaft  $l$ , which is known as the cam-shaft. Thus, the cam-shaft will be driven one-half as fast as the crank-shaft; or, in other words, it will make one revolution while the crank-shaft is making two.

On this cam-shaft are fastened two cams  $s, s_1$  that actuate two treadles  $p, p_1$ , to which are attached the harnesses, which are omitted in these views. These treadles have their fulcrum on a bracket  $p_2$ , which is fastened to the back girt of the loom. On each end of the cam-shaft there is a cam  $c$ , known as the **picking cam**, which, through suitable mechanism, actuates the picker stick  $d$  on the same side of the loom. At the bottom of the picker stick will be seen what is known as the **parallel motion**, which is shown more fully in Fig. 11. The picker stick is fastened to the rocker  $j$ , by means of a bolt, the rocker resting on a shoe  $j_2$ .

The upper end of the picker stick projects through the shuttle box  $n$  on the end of the loom lay. It will be noticed that there is a picker stick and also a shuttle box  $n$  at each end of the loom, and that all the parts are duplicated; but, since on plain looms both picker sticks work in exactly the same manner, only one is considered. The lay is supported by the lay swords  $l_3$ , which are fastened to the rocker-shaft  $l$ . Fastened to the top of the lay is a thin strip of

either hardwood or iron, known as the **race plate**, on which the shuttle runs in being thrown from one box to the other. The lay is connected to the crank-shaft by means of the crank-arms, and is thus given the motion required by this part of the loom.

One more cam on the cam-shaft that needs to be mentioned is the filling-fork cam  $u_1$ , shown in Figs. 1 and 2. This cam actuates the lever  $u_2$ , which in turn actuates the filling fork in such a manner as to stop the loom at any time the filling may be absent.

**6.** The loom beam on which is wound the warp, rests in the supports  $x_3, x_4$ . The yarn passes from the beam over the whip roll  $y$ , through lease rods, through harnesses that are connected by means of straps at the top to rolls and at the bottom to the treadles, and finally through a reed that is supported by the lay and held in place by means of the reed cap or lay cap  $k_2$ .

Referring to Fig. 1,  $a$  is the breast beam of the loom, over which the cloth passes. It then passes behind the roller  $h_1$ , around the sand roll  $h$ , and is finally wound upon the iron rod (cloth roll)  $f$ . The sand roll takes up the cloth and is driven by means of the take-up motion  $g$ .

## PRINCIPAL MOTIONS OF A LOOM

### SHEDDING

#### SHEDDING BY CAMS

7. Fig. 3 shows, in detail, the shedding mechanism of a plain loom;  $t$  is the cam-shaft;  $s, s_1$  the cams; and  $p, p_1$  the treadles to which the harnesses  $q, q_1$  are attached by straps. Above is the harness-roll shaft  $q_2$ , with the harness rolls  $q_3$ . The cams  $s, s_1$  act on the round bowls  $p_2, p_3$ , which revolve on studs set in the treadles;  $q, q_1$  are the harnesses required to be lifted to form the shed;  $q_4$  are the strap and jack-connections, which join the bottoms of the harnesses to their respective levers. These straps are capable of being lengthened or shortened as may be required;  $q_5$  shows the strap connections for the top of the harnesses. These straps are fixed to the rolls  $q_3$ , which are of different diameters. The rolls are setscrewed on a shaft  $q_2$ . The difference in the diameters of the rolls is required in order to compensate for the extra rise that must be given to the back harnesses so that the yarn drawn through it will rise to the same height as the yarn in the front harness. This would be more noticeable if several harnesses were employed. For the same reason the cam that actuates the back harness should always be larger than the one that actuates the front.

The manner in which the cams  $s, s_1$ , Fig. 3, cause the rise and fall of the harnesses  $q, q_1$  should be considered. Each cam moves the harness, which it actuates, in one direction only, straps and roller connections being necessary to bring the harness back to its original position. Thus, when the cam-shaft  $t$ , Fig. 3, revolves so that the cam  $s_1$  is in the position shown in this figure, the harness  $q$  will be lowered



by the direct action of this cam, forcing down the treadle  $p$ . When, however, the shaft  $t$  has revolved so that the cam  $s_1$  has assumed the position shown by the cam  $s$ , some other mechanism must be employed to lift the harness  $q$ , since the cam  $s_1$  not being connected in any manner to the bowl  $p_2$ , but simply coming in contact with it, will have no action on the harness  $q$  when it is rising.

The raising of the harness  $q$  is accomplished by means of the strap-and-roller connection shown in Fig. 3. As the cam  $s$  revolves, it forces down the treadle  $p_1$ , which in turn lowers the harness  $q_1$ . As this harness is lowered it turns the rollers  $q_5$ . The revolving of the rollers winds up the top strap connected to  $q$ , which raises that harness. Thus the downward motion of the harness  $q_1$  produces an upward motion of the

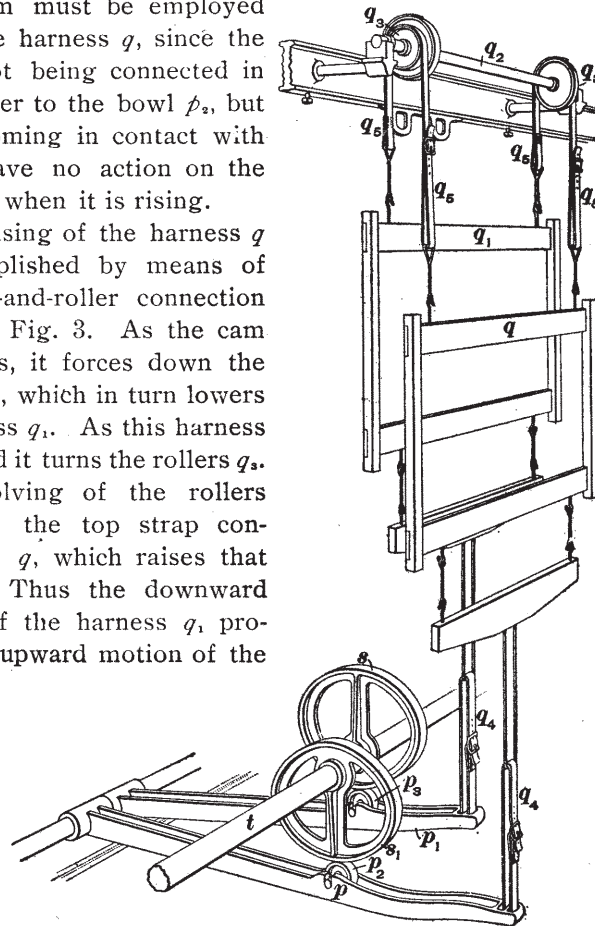

FIG. 3

harness  $q$ , and, consequently, as one harness is depressed to allow the yarn drawn through it to form the bottom of the shed, the other harness is raised in order to form the top of the shed.

Although inaccurate, the phrases *top shed* and *bottom shed* are frequently used in a mill. The word *shed* really indicates the entire space enclosed by the upper and lower lines of warp. The expressions *top shed* and *bottom shed*, as commonly used, are abbreviations for the expressions *top line of the shed* and *bottom line of the shed*, and as they have become popular, they will be used in this connection. The top and bottom lines of a shed are shown in Fig. 4, the arrows showing the direction of the simultaneous movement of each line so that the top line becomes the bottom, and vice versa, at the next pick.

Harnesses are placed at right angles to the warp ends, and must be so connected to the shedding motion that a vertical pull will be exerted upon them, for a side move-

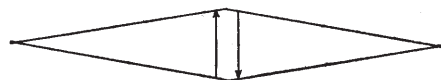

FIG. 4

ment, however slight, is detrimental to good weaving. They must also be moved at a

varying speed, in order that as little strain as possible will be brought on the yarn when the shed is open.

**8. Shape of a Cam.**—The ideal movement that can be given to a harness is to commence to lift or depress slowly, gradually increasing in speed to the center of the shed, when it again gradually becomes slower until the shed is formed. The strain on the warp ends rapidly increases as the warp approaches the upper and lower lines of the shed; therefore, it follows that when the shed is fully open, the warp yarns are at their greatest tension, and may be easily broken, especially if an abrupt movement is given to them. It is therefore necessary to give the easiest possible motion to the yarn when the shed is opened. As the shed closes, tension is gradually being reduced, and when in mid-position, there is little or no strain on the yarn; therefore, while passing the center of the shed, extra speed may be given to the yarn, in order to save time.

Harnesses actuated by cams are capable of approaching the nearest to this perfect form of shedding, since the

movement of the harnesses is positively controlled both in rising and falling. Consequently, if the cam is so shaped that it will give this movement, it will impart it to the harnesses. For this reason cams are always used to produce the shed on a plain loom.

**9. Construction of a Cam.**—When constructing a cam there are two points always to be considered. These are the *dwell of the cam* and the *size of the shed*.

By *dwell* is meant the length of time the harnesses are kept stationary in order to allow the shuttle to pass from one side of the loom to the other. This dwell is not always a constant quantity, since different makers adopt different methods. The dwell is obtained by having a portion of the cam constructed with its outer edge a true arc of a circle; thus, when the treadle is in contact with that part of the cam, there will be no motion of the harnesses.

In regard to the size of the shed formed by the cam, it can readily be understood that a

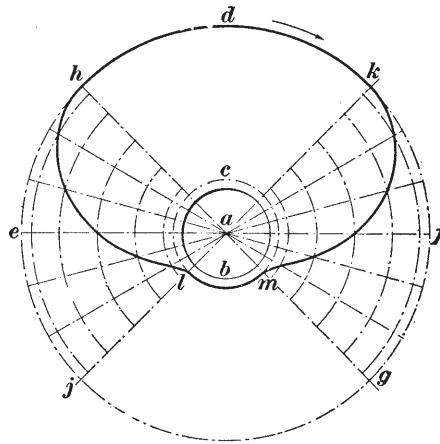

FIG. 5

cam constructed to give a certain size shed cannot be used in a loom where a much larger or much smaller shed is required. In illustrating the construction of a cam, one will be taken that is commonly used on plain work of ordinary counts.

Fig. 5 shows a cam with its construction lines. This figure illustrates a cam suitable for ordinary work, the change parts being drawn on lines that would give the harnesses a steady motion, while the dwell allows the shuttle a period equal to one-half a pick, in which to pass from one side of the loom to the other.

10. As has previously been shown, the cam-shaft makes one revolution while the crank-shaft is making two; consequently, one revolution of a cam on the cam-shaft will be equal to two picks of the loom.

With a center  $a$ , and a radius equal to one-half the diameter of the cam-shaft, describe the circle  $b$ . With the same center, and a radius equal to one-half the diameter of the cam-shaft plus the thickness of the cam-hub, describe the circle  $c$ . The circle  $c$  represents the inner throw of the cam. To the radius used in describing this circle add the full throw of the cam, and draw the circle  $d$ . The circle  $d$  represents the outer throw of the cam. The circles thus described give the essential parts of the cam from which to work.

Draw a line  $ef$ , dividing the circles into two equal parts. Next draw the lines  $gh$  and  $jk$ , having the lines cut the outer circle at points that will divide the circle into four equal parts  $hj, gj, gk, hk$ . Take the arc  $hk$  for the pause when the harness is at its lowest point, and the arc  $gj$ , on the opposite side, for the pause when the harness is at its highest point. Then the arc  $hj$  must be occupied in raising the harness from its lowest to its highest point, and the arc  $gk$  in moving from the highest to the lowest. The arc  $kh$  represents the dwell of the harness when lowered, and the arc  $gj$  the dwell when raised. Since each of these represents one-quarter of the circle  $d$ , the time occupied by the cam in moving through any one of these distances will be half a pick.

It is now necessary to draw curved lines from  $h$  to  $l$  and from  $k$  to  $m$ , of such form as to give to the harnesses the motion previously mentioned. In order to accomplish this, it is first necessary to divide the arcs  $hj$  and  $kg$  into any number of equal parts. Six parts are used in this illustration. Draw radial lines through these intersections.

Next divide the distance between the two circles  $c$  and  $d$  into the same number of unequal parts, commencing with a small division near the outer circle, increasing the size of the division as the center of the space is approached, and

then decreasing proportionately as the inner circle is approached.

With the common center  $a$  and radii equal to the distances from center  $a$  to the divisions made, describe arcs of circles cutting the radial lines previously drawn. From the point  $h$ , draw a curved line, having it pass through each of these intersections until it reaches the point  $l$ . From the point  $k$  draw a similar curved line until it strikes the point  $m$ . This will complete the necessary lines, and as a result the cam  $l h k m$  is obtained.

As this cam actuates one harness only, it is readily apparent that as many cams must be constructed as there are harnesses to be operated. These cams are so placed on the cam-shaft of the loom that they will not only give the desired lift to the harnesses, but also that each cam will actuate the harness which it governs, at the proper time.

It should also be noticed in this connection that the throw of the cam which actuates the back harness must be a little larger than that of the cam which actuates the front harness. Consequently, the hub of the back cam should be made a little smaller to allow the harness to be raised higher, and the outer circle made correspondingly larger to allow it to be depressed more.

**11. Treadles.**—The treadles of a loom may be considered as levers of the third class, since they have their fulcrum on a bracket bolted to the back girt of the loom, as previously explained, the weight being applied at the point where the harnesses are connected and the power exerted between these two. It will be seen, then, that the point of the treadle where the weight, or, in other words, the harness, is attached, in moving up and down, will describe an arc of a circle, and that the curvature of this arc will be inversely proportional to the length of the treadle; that is, the shorter the treadle, the greater will be the curvature. This will result in the harnesses being given a backward and a forward movement, which must be avoided, if possible; consequently, the length of the treadle

should as far as possible be such that this curvature will be reduced to a minimum.

Again, the bowl in the treadle should be so situated that its center, when the harness is in its central position, will be in a line perpendicular with the center of the cam-shaft, since if this is not done, the relative speed of the rise and fall of the treadle will be affected.

12. Another important point that should be noticed in connection with the cam is that at the central point of its

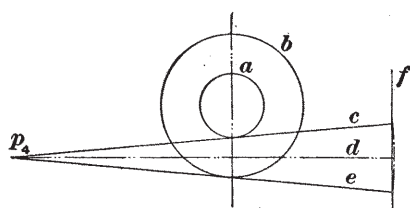

FIG. 6

lift the point of contact of the treadle with the cam should be level with the fulcrum of the treadle. This will insure the point at which the harness is attached moving the same distance above this central

position as it does below, thus lessening the tendency of the treadles to pull away from a straight line.

Figs. 6 and 7 illustrate this point. Dealing first with Fig. 6,  $p_4$  is the fulcrum of the treadle, or the point where it is attached to the loom. The circle  $a$  represents the inner throw of the cam, while the circle  $b$  shows its outer throw. From this it will be seen that the line  $c$  will be the line of the treadle when raised, and the line  $e$  will be the line of the treadle when lowered.

It will be noticed that these lines are equally distant from the central position of the treadle, which is represented by the line  $d$ ; consequently, the treadle will move away from the perpendicular line  $f$  the same distance in both its upper and lower positions, and it will also be noticed that this distance is the least possible with the conditions such as they are.

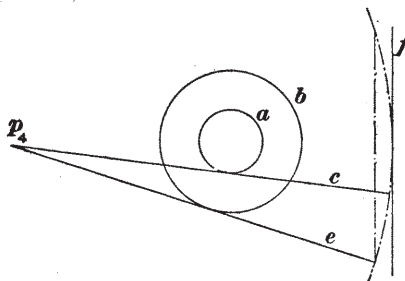

FIG. 7

In Fig. 7, the fulcrum  $p$ , of the treadle has been raised, and the result is readily seen. In this case, the end of the treadle, when at its upper position, is nearly in contact with the line  $f$ , but when lowered to the position represented by the line  $e$ , it will be noticed that it has been drawn some distance from the line  $f$ . Such a position of the treadles would result in the harnesses having a backward and a forward movement, which should be avoided as much as possible in weaving. This and other points raised in connection with the description of the construction of the loom and of loom fixing may appear trivial when considered in connection with one revolution of the cam-shaft, but when it is realized that a loom makes many picks per minute, sometimes as high as 200 or over, it will be seen that the neglect of such apparently small matters would result in much unnecessary vibration and damage to the loom and material.

**13. Throw of the Cam.**—As has already been stated, the **throw of the cam** is to be ascertained from the size of the shed required. If the length of the treadle and the length from stud or fulcrum to point of contact with the cam are known, the throw necessary to give this shed is easily obtained.

Since the length of the arc through which any point of a lever moves is directly proportional to its distance from the fulcrum, we have the following simple proportion: Size of the shed : throw of cam = whole length of treadle : length of treadle from fulcrum to point of contact. This gives the following rule:

**Rule.**—*To obtain the desired throw of cam, multiply the size of shed required by the length of the treadle from the stud or fulcrum to the point of contact, and divide this result by the whole length of the treadle.*

**EXAMPLE.**—The length of treadle is 30 inches, distance from stud to contact 18 inches, and the shed required 3 inches; what should be the throw of the cam?

**SOLUTION.**—According to the rule:  $18 \times 3 = 54$ . Dividing by the length of the treadle,  $54 \div 30 = 1.8$  in., the throw of the cam. Ans.

## PICKING

14. After the harnesses have been opened and a shed formed, the shuttle that contains the filling must be thrown from one side of the loom to the other, passing through this

opening and leaving a pick of filling. This action of the loom is known as **picking**. It is a motion entirely different from any other movement of the loom, and is one in which a considerable amount of force must be exerted at a given moment.

There are several styles of picking motions in general use on power looms at the present time. In America, the two principal ones are the *shoe*, or *bat-wing pick*, and the *cone pick*, but as the cone pick is the one in general use on plain cotton looms, that alone will

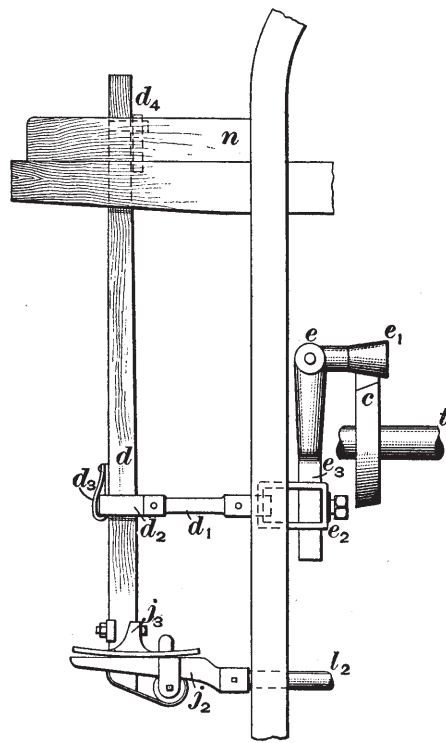

FIG. 8

be dealt with at present. The one here referred to is an **under-pick** motion.

Figs. 8 and 9 are views of the picking motion; *c* is the picking cam on the cam-shaft *t*; *e<sub>1</sub>* is the cone on which the cam acts; *e* is the picking shaft. Fastened to the end of the picking shaft is the picking-shaft arm *e<sub>3</sub>*, to which is fastened a collar *e<sub>2</sub>*. Fastened to *e<sub>2</sub>* is a short lug strap connected with the lug stick *d<sub>1</sub>*. Another lug strap *d<sub>2</sub>* connects the lug stick with the picker stick *d*. At the foot of the picker stick is the



parallel motion, which consists of the rocker  $j_s$ , shoe  $j_2$ , and other parts shown.

The action of the picking motion is as follows: As the projecting part, or nose, of the cam in revolving on the cam-shaft strikes the cone  $e_1$ , it forces it upwards. This, in turn, throws the bottom of the shaft arm  $e_3$  inwards, which movement draws the picker stick toward the loom by means of connections consisting of a lug stick and lug straps, as previously explained. The picker stick, by means of the force with which it is drawn in, delivers a blow to the shuttle sufficient to send it across the loom and into the opposite box. After the shuttle has entered the opposite box, a picking motion of exactly the same construction will then throw it back again across the loom.

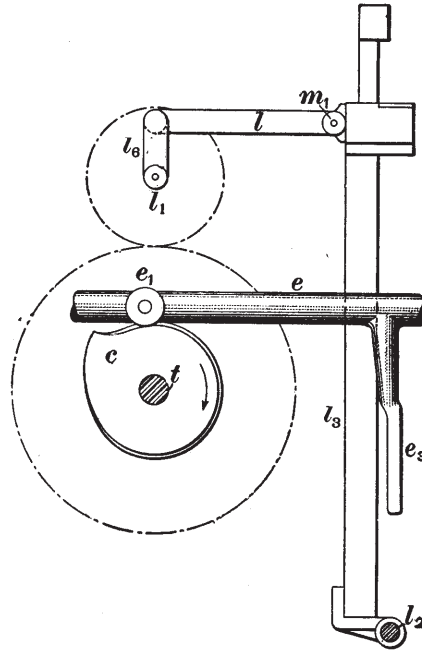

FIG. 9

It will readily be seen that the intensity of the force with which the picker stick  $d$  is thrown in toward the loom will depend on the intensity of the force that the cam  $c$  imparts to the cone  $e_1$ . This, of course, will depend to a great extent on the shape of the cam.

**15. Picking Cams.**—Although a picking cam differs very materially from the harness cam, yet in constructing a picking cam a principle must be adopted similar to that used in the construction of the shedding cams; that is, the first

portion of the rise must be gradual, so that it will commence to move the shuttle gradually and increase in velocity toward the end of the stroke. The construction of a picking cam will depend on the force that the cam is required to exert, and on the amount of time in which it is allowed to exert the required force.

Fig. 10 illustrates these two points;  $a c f g$  represents the outside line of a cam. When the cam revolves until the part  $c$  comes in contact with the cone, it will commence to move the picker stick. From  $c$  to  $a$  is occupied in delivering the pick. By extending the line  $c g$ , until it cuts the outer circumference, the arc  $a d$  is obtained, through which the point of the cam moves while delivering the blow. If the

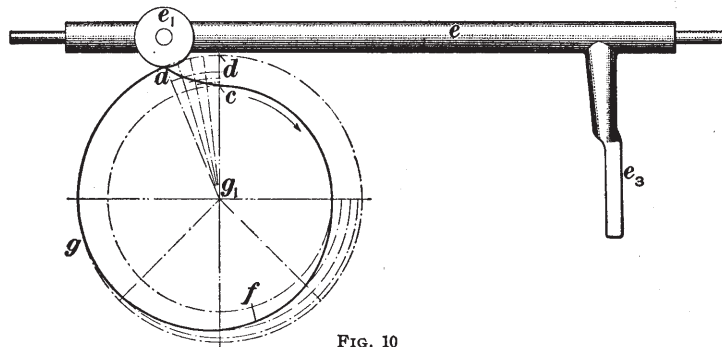

FIG. 10

distance from  $a$  to  $d$  is lessened, it can readily be seen that, with the cam revolving at the same rate of speed, more power will be exerted. But this would result in a harsh pick, which should be avoided as far as possible. If, on the other hand, the distance should be increased, less power will be exerted. This would result in a smoothly running pick, but could be carried to such an extent that the picker stick would not receive the required power to enable it to send the shuttle across the loom.

The size of cam and the curves required have been found very largely by experiment; for, while it is possible to figure the length of the arms on the picking shaft and the length of

the cam-point to move the picking stick a certain distance in the shuttle box, the amount of force sufficient to throw the shuttle has been very difficult to determine, since the amount of resistance with which the shuttle meets in passing through the shed varies to a great extent on different kinds of work.

**16.** If a perpendicular line should be drawn passing through the center of the cam-shaft, it would be found that the cone was set some distance back of this line. The object of placing the cone in such a position is that the force of the cam may be exerted while moving upwards. If the cone were set directly over the center of the cam-shaft, a good deal of the force would be exerted in a horizontal direction, and since the motion of the cone is vertical, or nearly so, it will be readily seen that a cone set in this position would result in a very harsh and undesirable pick.

It will be noticed by reference to Fig. 8, that the diameter of the cone  $c_1$  varies. The active surface of the picking cam is also beveled at varying angles to fit the surface of the cone, so that the face of the cam may be constantly in full contact with the cone.

**17. Parallel Motion.**—The parallel motion is one of the many parts of a loom necessary to the perfect working of the whole, but especially to the picking. Probably no part of the construction of a loom is subject to so much criticism as the picking motion, and by no means the least important part of the picking motion is the parallel motion. A picking cam could be of a perfect shape, and the cone in the exact position for its best working, yet, if the parallel motion were wanting in exactness, the result would be undesirable.

Fig. 11 is a view of the parallel motion showing also the picker stick and shuttle box, the picker stick being at its backward position;  $j_s$  is the rocker of the parallel motion to which the picker stick  $d$  is attached by means of a bolt, as shown in the illustration. This rocker rests on a shoe  $j_s$ , and is held in position simply by a projection  $j_s$ , which passes through a slot cut in the rocker, the rocker thus

being allowed a free movement as the picker stick moves backwards and forwards.

The strap  $j_4$ , one end of which is fastened to the picker stick, while the other end is fastened to a coil spring  $j_1$ , serves to bring the picker stick to its backward position after it has delivered the shuttle. It also keeps the rocker down on the shoe, preventing it from springing upwards while picking.

**18. Picker sticks** serve to transmit the power imparted by the picking cam. As considerable strain is brought to

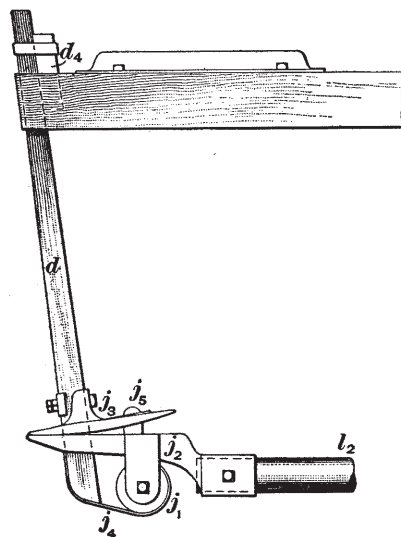

FIG. 11

such a shape as to receive the shuttle point.

**19. Object of the Parallel Motion.**—The object of the parallel motion is to move the picker in a direction as nearly as possible parallel to the race plate. It will be noticed that without some such arrangement, the picker in traveling from one end of the box to the other would describe an arc of a circle. This would give it a higher position at one part of its movement than at another, thereby resulting in a very unsatisfactory pick.

bear on them, the splitting of picker sticks is a common occurrence in the weave room.

Fastened to the upper end of the picker stick is the part  $d_4$  known as the picker. On plain looms the picker is generally made of leather and is fastened to the picker stick by means of a collar which passes around the upper end of the picker and is connected to the picker stick. In the front part of the picker, a hole is cut of

To remedy this the loom builder has adopted the parallel motion.

The shoe of the parallel motion is perfectly level, while the rocker to which the picker stick is fastened is curved. This curve of the rocker is such that it forms the arc of a circle that would be drawn by using the picker as a center, and a radius equal to the distance from the picker to the shoe of the parallel motion. Thus, it will be seen that as the picker stick moves backwards and forwards, its fulcrum being at the rocker, the upper end, or the picker, will be at the same level when at the back of the box as at any other point.

**20. Shuttle Box.**—The shuttle box is simply a continuation of the race plate, with the exception that sides are added in order to receive the shuttle.

Some looms have a **binder** placed on the back of the box, while on others it is at the front; these binders are made of wood or iron, and are of a suitable shape to project into the box. Its outer end works on a stud and is adjustable; the other end is held in position by a finger on the protector rod, this finger being kept pressed against the binder by means of a spring on the protector rod. The shuttle must overcome this spring when entering the box. Leather checkstraps are also placed around these fingers to further check the shuttle.

**21. Shuttles.**—The object of the shuttle is to deliver a pick of filling from the cop, or bobbin, that it holds. Shuttles are made of wood; they are hollowed out in the center for the reception of the cop, or bobbin. A metal tip is inserted at each end to protect the shuttle and to present a smooth point to the yarn when passing through the shed. In the shuttle, a metal tongue, or spindle, is inserted which is hinged at one end and extends almost the entire length of the hollow part of the shuttle. The tongues, or spindles, are of various shapes, but the aim of all is to hold the cop, or bobbin, firmly while the shuttle is in use. A small porcelain or iron eye is placed at one end of the shuttle through which the filling runs while being unwound.

## BEATING UP

22. As the shuttle is thrown from one side of the loom to the other, part of the filling that it contains is left in the shed. This is known as a **pick of filling**. It now becomes the object of the loom to push this filling up to the cloth previously woven; this operation is known as beating up and is performed by the **lay of the loom**, in which is placed the reed dividing the warp threads.

This motion is shown in Fig. 12, which gives a view of the **lay** and its connections; the lay *k* is supported by the lay swords *l*, which are attached to the rocker-shaft placed near

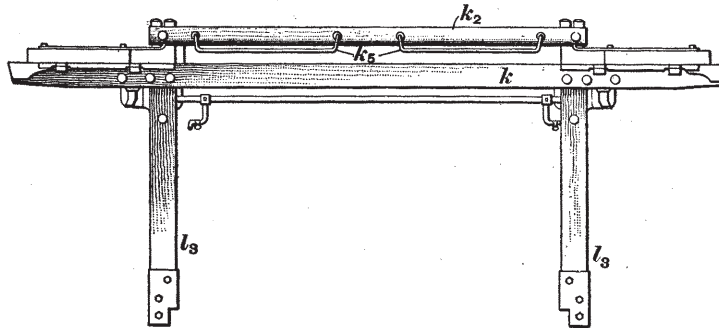

FIG. 12

the floor. This shaft is held by two brackets in which it is free to oscillate.

The lay consists of a heavy piece of wood extending from the outside end of one shuttle box to the outside end of the opposite box. The extra weight and strength for heavy work is sometimes obtained by bolting iron plates on the back and front. On the top of the lay *k* is fastened the race plate, which is usually a thin piece of straight-grained hardwood screwed to the lay. In most cases it forms a perfectly straight surface. Sometimes, however, it is gradually hollowed at the center so that it is from  $\frac{1}{8}$  to  $\frac{1}{4}$  inch below a straight line. In some looms the race plate consists of a thin strip of iron.

A groove is cut in the lay for the reception of the reed, and there are also two slots, one at each end, for the reception of the picker sticks, as has already been explained. The reed cap  $k_2$  has a groove on its under side in which sets the top of the reed. The reed is held in position by the grooves in the lay and reed cap, the reed cap being bolted to the lay swords as shown in Fig. 12.

The movement of the lay is obtained by means of the crank-shaft  $l_1$  and the crank  $l_2$  shown in Fig. 9;  $l$  is the crank-arm, which is connected to the crank  $l_2$  by a leather or steel strap. A similar connection is made at the lay sword where a pin  $m_1$  is placed, the crank-arm being attached to it by another steel band.

The object of driving the crank-shaft at twice the speed of the cam-shaft will now be readily apparent, since it will be seen that it is necessary for the lay to beat up the filling at each pick of the loom and, although one revolution of the cam-shaft causes two sheds to be formed, and, consequently, two picks to be placed in the cloth, yet one revolution of the crank-shaft serves to move the lay forwards only once, and therefore drives the filling up to the cloth only once.

The lay serves two purposes: first, it beats up the filling, and, second, it acts as a rest on which the shuttle may slide, in passing from one box to the other. These are, in a certain sense, opposed to each other, since when the lay is beating up the filling, it should give a quick, sharp blow; while on the other hand, when it is carrying the shuttle, its motion should be slightly retarded. Consequently, the lay must be driven in such a manner that it will have a varying speed. In other words, the driving arrangement must be eccentric.

**23. Eccentricity of Lay.**—In Fig. 13, the line  $ab$  represents the position of the lay and lay sword when at their forward throw, and the line  $ac$ , when at their backward throw;  $d$  represents the circle described by the crank in revolving. It will be noticed that the line  $bc$  represents the

throw of the lay; therefore, this distance must be equal to the diameter of the circle described by the crank.

When the lay is at its forward throw, the crank must be at its front center, which is *f*. This gives the length of the crank-arm, which is *bf*. If the center *g* of the throw of the lay is taken as a center, and an arc described with a radius equal to the length of the crank-arm, it will be found to cut the circle of the crank at *1* and *2*. Therefore, while the lay

is moving from *g* to *b* and back to *g* again, which is half a stroke, the crank moves from *2* through *f* to *1*.

On the other hand, while the lay is moving

from *g* to *c* and back to *g* again, which also is half a stroke, the crank is moving from *1* through *e* to *2*. But it will be noticed that the arc *2f1* is smaller than the arc *1e2*, and since the crank revolves at the same rate of speed, the shorter distance must be traveled in a shorter time. Therefore, the lay in moving through its forward stroke, or from *g* to *b* and back to *g*, will travel faster than while accomplishing its backward stroke, or from *g*

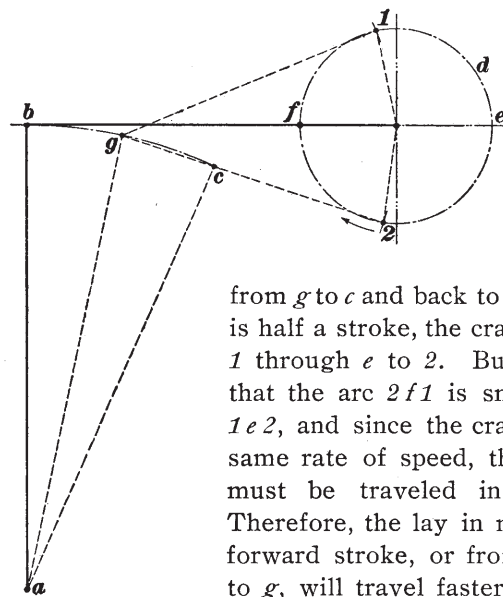

FIG. 13

to *c* and back to *g*. This is known as the **eccentricity of the lay**, and the amount of this eccentricity is indirectly proportional to the length of the crank-arm, and directly proportional to the diameter of the circle described by the crank. The larger the circle and the shorter the crank-arm, the greater will be the eccentricity.

Two or three other important points connected with the eccentricity of the lay should be carefully noted. It will be readily seen that on all looms it is essential that this eccentricity should be great enough to allow the shuttle



time to pass from one box to the other; while on the other hand, if the throw of the crank should be increased, the distance through which the lay moves would be increased proportionately. This would produce a greater chafing of the warp yarns, which should be avoided as much as possible. The method adopted by loom builders to overcome this difficulty, is to place the crank-shaft in a lower plane than the point where the crank-arm is connected with the lay. By increasing the diameter of the circle described by the crank in proportion to the length of the crank-arm, the requisite amount of eccentricity is obtained, and at the same time the crank is taken out of the way of the warp.

It will be noticed, in the illustration, that the line *ab*, or the position of the lay at its forward stroke, is vertical. The lay is set in this manner so that the reed, when it strikes the cloth in beating up the filling, will be at right angles to the cloth. If the lay were allowed to pass this central position in its backward and forward swing, it would also cause a vibration of the loom, which would be very detrimental to its good working.

**24. Bevel of the Race Plate.**—When the lay is in its backward position, the bottom shed forms an angle to a line that is horizontal. The race plate of the lay, when in this position, should form a similar angle; that is, it should be parallel with the bottom shed of the warp; but it will be noticed that the reed is constantly in a line parallel with the swords on which the lay works; consequently, this will cause the race plate and the reed to form what may be called a **groove**, when the shuttle is being thrown from one box to the other. This will result in the shuttle running much more steadily and being less liable to fly out.

**25. Reeds.**—One object of the reed is to guide the shuttle while passing from one box to the other and, in order to accomplish this object, it is very essential that the reed should be perfectly straight and in an exact line with the back of the box.

A reed consists of a top and bottom rod  $a, a_1$ , Fig. 14, into which are set flat wires  $b$ . These wires are securely fastened in place by winding tarred cord  $c$  between them and around the rods. The warp ends are drawn between these wires—a certain number between each two consecutive wires; thus the reed also serves to hold the warp ends in their correct position while the lay is passing back and forth in beating up the filling.

Reeds are spoken of as having so many *dents per inch*, that is, so many wires to each inch lengthwise of the reed. This number varies very largely in the cotton trade, running from six to ninety. A different number of ends to the dent

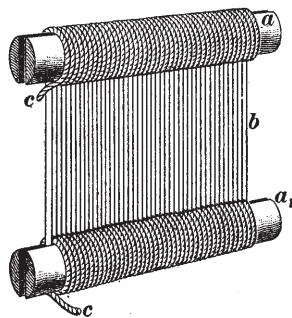

FIG. 14

will be found to be drawn through reeds, the most common number being two ends per dent. Thus, the reed serves to determine the fineness of the cloth; that is, it governs the number of warp ends in each inch of cloth.

**26. Fast Reeds.**—In the majority of looms run at the present time, the reed is securely fastened to the lay, being held perfectly rigid. With such a construction, it is very evident that if the shuttle

has, for any reason, failed to get well into its box and is still in the shed when the reed is in the act of beating up the filling, the result will be the straining of the warp threads, and the breaking of some of them.

**27. The Protector.**—When a loom is provided with a fast reed, it also contains a device called a **protector**, the object of which is to guard against such conditions. Such a device is shown in Fig. 15;  $k$  is the lay on which the shuttle runs. The protector consists of a rod  $b_1$  that runs the whole length of the lay between the boxes and rests in two or three bearings fastened to the under side of the lay. At each end of the lay this rod is curved and carries a finger  $b_2$  that presses against the binder  $k_1$ , as has been described. On the

end of the rod that is at the shipper side of the loom, there is placed, in addition to the finger, a projection *b* known as the **dagger**. On the loom frame is a casting *c* known as the **frog**. This frog contains a steel bunter *d* on its upper side corresponding to the shape of the edge of the dagger. Bolted to the frog is a bracket *b*<sub>3</sub>, Fig. 22, so set that it is nearly in connection with the shipper of the loom.

The action of the protector is as follows: When the shuttle enters the box, the binder *k*<sub>1</sub> is pushed outwards and

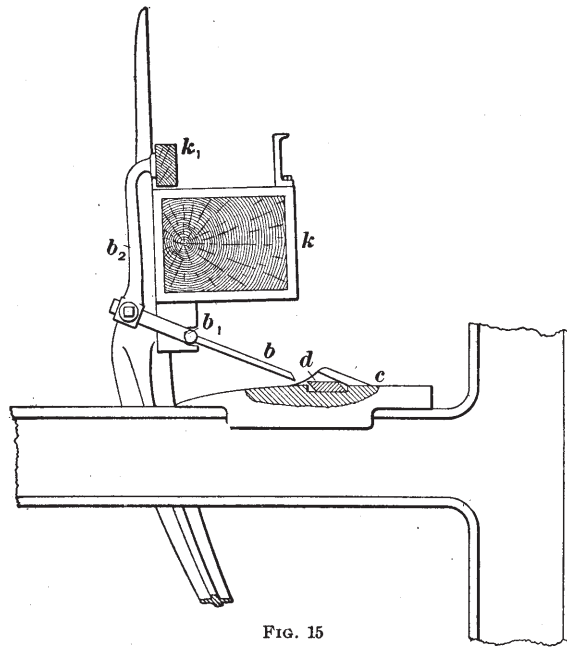

FIG. 15

pushes back the finger *b*<sub>2</sub>. This causes the dagger *b* to be lifted so that as the lay comes forwards the dagger passes over the steel bunter *d* in the frog. If for any reason, the shuttle fails to enter the box, the binder remains stationary and the finger *b*<sub>2</sub> retains its position, so that when the lay comes forwards, the dagger engages with the frog, thus checking the movement of the lay. But in doing this, the frog is pushed forwards sufficiently to enable the bracket to

push against the shipper and throw it out of position, thus shifting the belt from the tight to the loose pulley.

Frequently the binder is placed at the front of the box. In this case, the dagger is placed on the protector rod at the center of the lay, while the bunter is at the center of the breast beam and on the under side; but since the action of both is very similar, only one has been described here.

**28. Loose Reeds.**—In the case of loose reeds, the reed *b*, Fig. 16, is held in position by a loose board *b*<sub>1</sub>. This

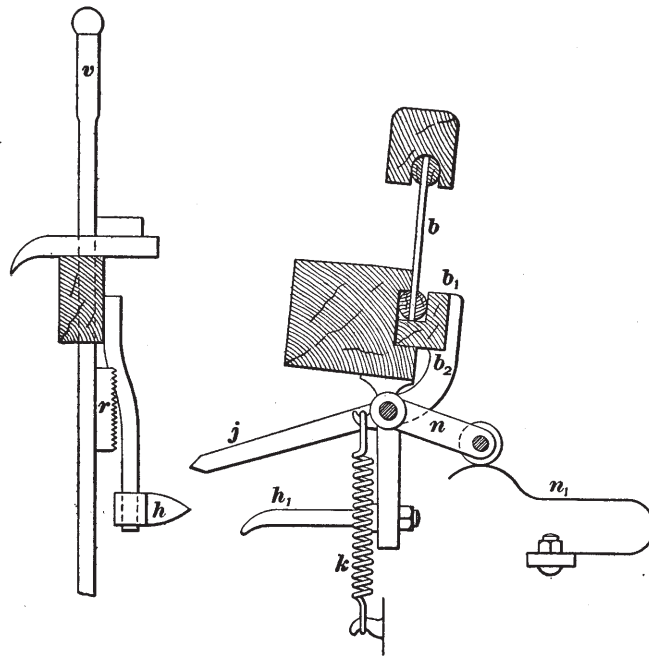

FIG. 16

board extends the entire length of the reed and is held by means of a lever *b*<sub>2</sub>, to which is attached a spring *k*. When the lay is at its backward stroke and the shuttle is being thrown across the loom, the board *b*<sub>1</sub> is held more strongly by means of the lever *n*, which comes in contact with the spring *n*<sub>1</sub>. When the shuttle from any cause is trapped in the shed, the pressure of the shuttle against the reed, caused by

the warp yarn pressing against the shuttle, is sufficient to throw out the reed and thus release the shuttle.

It will be noticed that with such an arrangement and without any additional mechanism, the reed would be unable to deliver a sufficiently strong blow in beating up the filling. To overcome this difficulty, a frog  $h$  is placed on the front of the loom in such a position that, as the lay comes forwards, a finger  $h_1$  attached to the lever, which holds the board against the reed, will just slide beneath the frog, thus holding the reed securely in position. This attachment is so arranged that it cannot act until the shuttle is well into the box, thus preventing any liability of the reed being fast so long as the shuttle is in the shed.

When the reed is knocked out by the action of the shuttle, the loom will be stopped by means of the dagger  $j$ , the action of which is as follows: The reed in being pushed back by the shuttle will throw the loose board  $b_1$  with it, thus raising the dagger  $j$ , which as the lay comes forwards will come in contact with the casting  $r$  on the shipper handle  $v$ , thus throwing  $v$  out of its retaining notch and stopping the loom. As long as the shuttle is not trapped in the shed, the board  $b_1$  will retain the position shown in the figure, and the dagger  $j$  will slide below the casting  $r$ , and, consequently, will not interfere with the shipper handle. The loose reed loom is commonly used in England and other European countries.

## AUXILIARY MOTIONS OF A LOOM

---

### LET-OFF MOTIONS

**29.** The motions dealt with in the following articles are termed the **auxiliary motions** of the loom; although secondary to those dealt with, they are extremely necessary to the satisfactory working of all power looms.

**Let-off motion** is the name applied to a motion employed to control the warp, allowing the necessary amount of yarn to be unwound from the beam and at the same time holding the yarn at a sufficient tension while the cloth is being woven. Two important points should be kept in mind when considering it: First, all let-offs are regulated by the tension on the warp yarn; that is, in all cases the tension on the warp threads must be sufficient to overcome a certain resistance before the yarn will unwind from the beam. Second, the position of the lay when the yarn is let off should be carefully noted.

To obtain the best results on plain looms, the warp should be as tight as possible when the filling is being beaten up. In accomplishing this object, however, one difficulty is met with. When the shed is open there must be a greater length of yarn between the warp beam and the edge of the cloth than when the yarn forms a straight line; and, since the reed strikes the cloth when the yarn is level or when it is starting to open for the next pick, it must follow that the yarn would be slack at this point if there were not some arrangement to prevent it. This is provided for generally by making the whip roll—over which the warp passes—oscillate, so that when the yarn is slack the whip roll, by moving upwards, will take up the slack, and as the yarn is tightened again by the shed opening, the whip roll will be pulled down, thus relieving the yarn.

The simplest let-off motion, and one quite generally used, is the ordinary **friction let-off**. This consists of a rope, or in some cases a chain, wound two or three times around the beam head, one end of this rope or chain being made fast to the loom frame, while the other end is attached to a lever about 6 inches from the fulcrum. Weights are placed on this lever sufficient to give the required tension.

So-called **automatic let-offs** are frequently used on looms,

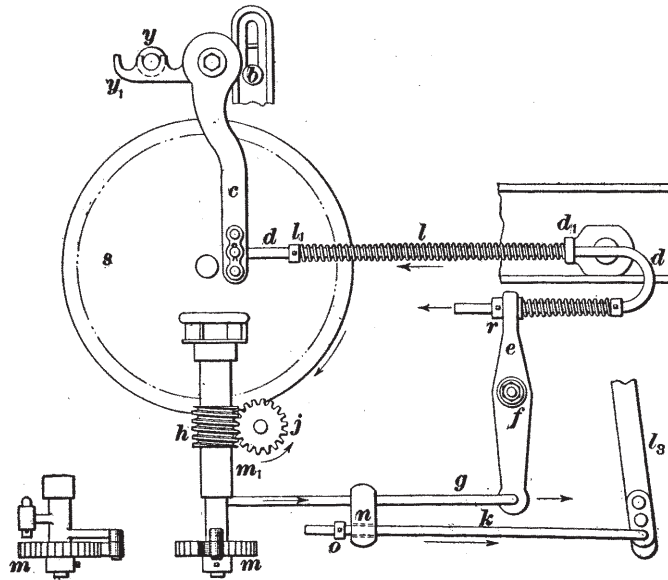

FIG. 17

and a description of the two most commonly used will serve to illustrate the principle of this class of let-off motions.

**30. Bartlett Let-Off.**—Fig. 17 is a view of the **Bartlett let-off** as applied to looms. The whip roll *y* sets in brackets *y*<sub>1</sub> that are setscrewed to the whip-roll shaft, which is supported by brackets fastened at the point *b*. The whip-roll shaft sets loosely in these brackets and is free to turn in either direction. On the end of the whip-roll shaft is an arm *c* connected at its lower end to the rod *d*, which is

curved at the other end. This rod is held in position by the support  $d_1$ , in which it slides. The short arm of the rod  $d$  passes through the top of an upright arm  $e$ , which oscillates on a stud  $f$ , the lower end of this arm being attached to a rod  $g$ . On the end of this rod is a bracket carrying a pawl, which operates the ratchet gear  $m$  at the bottom of a shaft  $m_1$  containing a worm  $h$ . The shaft  $m_1$  is kept from turning, except when acted on by the pawl, by means of a friction strap that passes around a friction pulley on this shaft. The worm  $h$  drives the worm-gear  $j$ , which is on a shaft containing a gear that drives the beam by gearing into the teeth on the beam head. Working loosely in the collar  $n$  is the rod  $k$ , which is operated by the lay sword  $l_3$ , as shown in the figure.

The operation of this let-off is as follows: When sufficient tension has been placed on the whip roll by the warp yarn pressing on it, the whip roll will be depressed. This will cause the lower end of the arm  $c$  to be thrown in, compressing the spring  $l$  and bringing  $r$  in contact with the upper end of the oscillating rod  $e$ . As a result, the lower end of the arm  $e$  with the rod  $g$  will be thrown toward the beam  $s$ . As the rod  $k$  is brought forwards by the lay sword, the collar  $o$  will come in contact with the collar  $n$ , which is fastened to the rod  $g$ . This will bring the rod  $g$  into its former position; but in doing this it will cause the pawl to engage with and turn the ratchet gear  $m$  and thus, through the train of gears described, turn the beam  $s$  and let off the yarn. The arrows show the direction in which the parts move when operated by the rod  $k$ .

The throw of the pawl that operates the gear  $m$ , and consequently the amount of yarn let off at one time, can be regulated by adjusting the collar  $n$ .

The tension of the yarn is governed by the spiral spring  $l$ , which may be regulated by the collar  $l_1$ . It will be seen that if the spring is compressed by moving the collar, it will require more strain on the whip roll to further compress it so as to let off the yarn. In some cases when changing from heavy to light work, or vice versa, it may be found necessary



to change this spring entirely in order to compensate for the difference in the amount of strain that the different yarns will stand.

**31. Morton's Let-Off.**—Fig. 18 represents a sketch of another let-off motion in common use, named **Morton's let-off motion**, which is shown attached to the loom in Fig. 1. This also works in connection with the whip roll, which keeps it under constant control. Until the yarn

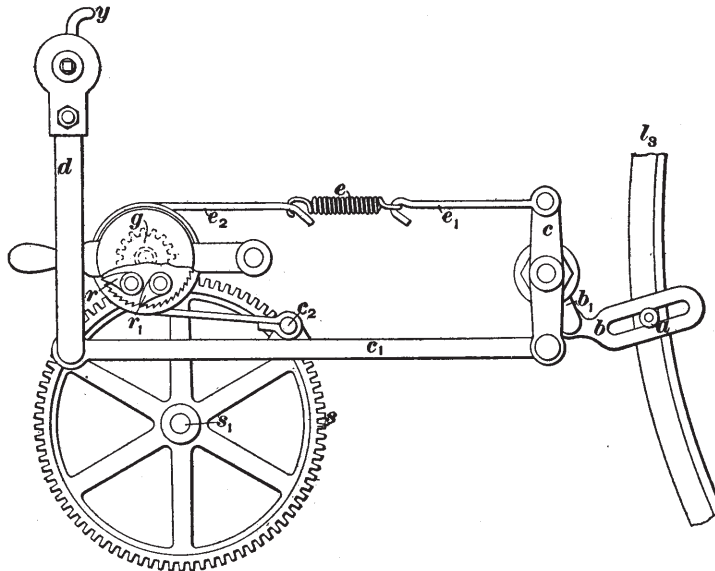

FIG. 18

is drawn tight no warp can be let off, and then the amount liberated is so small that it makes the action almost continuous.

Referring to Fig. 18,  $l_3$  shows the lay sword of the loom, connected to which is a pin  $a$ , that slides in a slotted lever  $b$ . This lever, being connected to the lever  $b_1$ , imparts motion to the rocker  $c$  through the aid of a coil spring on the stud on which the rocker  $c$  works. At its lower end, the rocker  $c$  is connected to a rod  $c_1$ , which in turn is connected to an oscillating rod  $d$ , this latter rod being fastened to the whip

roll  $y$ . Connected to the rod  $c_1$  at the point  $c_2$  is a strap  $e_2$  which, passing partly around an internal ratchet gear, is connected to the upper end of the rocker  $c$  by means of the spring  $e$  and the rod  $e_1$ . The ratchet gear has in connection with it a plate, on the inner side of which are placed two pawls  $r, r_1$  that engage with the teeth of the ratchet. Fastened to the ratchet gear is the gear  $g$  engaging with the gear  $s$  on the shaft  $s_1$ . On the inner end of this shaft is a pinion that gears into the warp beam.

The action of this let-off motion is as follows: As the warp becomes tight the whip roll is drawn forwards, the lower end of the oscillating rod  $d$  moving correspondingly backwards, drawing with it the rod  $c_1$ . This will result in the upper end of the arm  $c$  moving forwards, drawing with it the rod  $e_1$ , spring  $e$ , and strap  $e_2$ . The strap  $e_2$  being held tightly against the outer surface of the ratchet gear will turn the gear, since the pawls offer no resistance to the ratchet gear when revolving in this direction.

The internal ratchet gear in being revolved will, through the train of gears mentioned, turn the warp beam and thus let off a certain amount of warp. The rocker  $c$  in being moved in the manner described will cause the lower end of the lever  $b_1$  also to be moved backwards, bringing with it the slotted lever  $b$ . When the lay next beats up the filling, the pin  $a$  on the lay sword will engage with the outer end of the slot in which it works, and by this means bring the different parts of the mechanism to their original position. In doing this, however, the strap  $e_2$  instead of imparting any motion to the internal ratchet gear when moving in this direction, will slip on the outer surface of the gear owing to the gear being held by the pawls  $r, r_1$ .

It should be noticed that with this mechanism the warp yarn is let off when the shed is wide open, or, in other words, when the most strain is brought on the yarn. This is considered to be an advantage in weaving.

### TAKE-UP MOTION

**32.** The **take-up motion**, as its name implies, is for the purpose of taking up the cloth as it is being woven; and by the rapidity or slowness with which it performs this action it also determines the closeness of the filling, as the reed determines the closeness of the warp threads.

The take-up most commonly found on plain looms, and the one that will be considered, is known as the **intermittent take-up**. This motion is operated by a pawl that drives a train of gears, which in turn drives the sand roll around which the cloth is wound. Different makes of looms have the pawl of the take-up motion operated by different parts of the loom; thus, on some looms it is operated by an eccentric or cam on the cam-shaft. Since the cam-shaft makes only one revolution while two picks are being placed in the cloth, it will be seen that a take-up motion driven in this manner will operate only once in two picks.

While this answers all purposes for cloth that contains a large number of picks, it is not as satisfactory for light-pick goods, since it has a tendency to give the filling the appearance of having been placed in the cloth two and two. The pawl may also be operated from either the lay sword or crank-shaft, and, since these parts act during each pick of the loom, the take-up motion will be operated at each pick.

Fig. 19 is an illustration of a take-up motion that is operated by an eccentric *a* on the cam-shaft. As the cam-shaft revolves, the pawl *b* is pushed forwards, when it engages with a tooth on the gear  $g_1$ ; then, as the cam-shaft revolves, the arm is brought back again, turning the gear  $g_1$  one tooth; *d* is a pawl that engages with and holds the gear  $g_1$

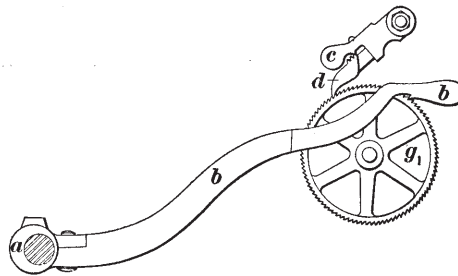

FIG. 19

while the pawl  $b$  is being brought forwards to engage with another tooth.

A better idea of the manner in which motion is imparted to the sand roll from the gear  $g_1$  may be had by referring to Fig. 20, which shows the train of gears through which this motion acts;  $g_1$  in this figure corresponds with the gear  $g_1$  in Fig. 19, which is directly acted on by the pawl of the take-up motion. On the same stud with  $g_1$  is the gear  $g_2$ , shown in the end view of this motion;  $g_2$  engages with the gear  $g_3$ , which is on the stud with the gear  $g_4$ ; this last gear drives the gear  $g_5$ , which is on the end of the sand roll  $h$ . Thus,

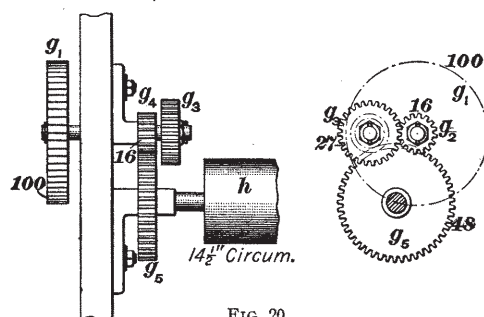

FIG. 20

through the gears  $g_2$ ,  $g_3$ ,  $g_4$ , and  $g_5$ , the gear  $g_1$  turns the sand roll  $h$ , which carries the cloth forwards.

When a loom is stopped on account of the filling running out or breaking, its momentum generally carries it at least two picks before it stops; consequently, if there is nothing to prevent it, the take-up motion will operate for these two picks, although there is no filling being placed in the cloth. Then when the filling is replaced and the loom started, a thin place will appear in the cloth.

To overcome this difficulty the pawl  $d$ , Fig. 19, is constructed in such a manner that, when necessary, it will occupy a different position from what it does while holding the gear  $g_1$ . As the loom is stopped by the filling running out or breaking, a lever that extends from the filling stop-motion will raise the catch  $c$  and pawl  $d$ , allowing the pawl to drop into the position shown in the illustration; then as

the loom is started again and the pawl  $b$  operates the gear  $g_1$ , the pawl  $d$  instead of holding the gear  $g_1$  will be pushed back until it regains its former position, the catch  $c$  dropping into the teeth on the pawl  $d$  and holding it at each pick. It will be seen from the illustration that the loom will have to run three picks before the take-up motion will commence to wind up the cloth. This is known as a *let-back* motion.

---

### FILLING STOP-MOTION

**33.** The **filling stop-motion** is applied for the purpose of stopping the loom when the filling is broken or the bobbin is empty. Without this motion the loom would continue to run until stopped by the weaver. A view of the filling stop-motion is shown in Fig. 21 (*a*) and (*b*), the latter being a top view of the filling-fork slide and its connection with the shipper handle.

This motion is situated at one side of the loom between the selvage of the cloth and the shuttle box. Fastened to the cam-shaft of the loom is the cam  $u_1$ , known as the filling-fork cam. This cam, in revolving with the shaft, will alternately lower and lift the lever  $u_s$ , which is on the stud  $u$ , the upper arm  $r$  being fastened to the lever  $u_s$ . Thus, as the lower part  $u_s$  is moved up and down by the cam  $u_1$ , the upper arm  $r$  will receive a backward and forward motion.

The filling fork  $u_2$  is pivoted at the point  $s$ , its forward end resembling an ordinary three-pronged fork and being bent almost at right angles to the main part; the other end is bent in the same direction about  $\frac{3}{8}$  inch from the end, thus allowing it to catch, when necessary, in the upper end of the lever  $r$ , which is curved to facilitate catching the fork. The filling fork is so nicely balanced that the least pressure on its forward end will cause it to swing on its pivot, thus giving it the position shown by the dotted lines.

In studying this motion, it should be understood that as long as the loom is running, the upper end of the lever  $r$  is constantly receiving a backward and forward motion, due to the action of the cam  $u_1$  on the lower end of the lever  $u_s$ .

As the pick of filling left in the shed by the shuttle is pushed forwards by the reed, it will come in contact with the prongs of the fork  $u_2$ , thus pushing this end of the filling fork toward the front of the loom and at the same time raising its other end out of contact with the upper part of the lever  $r$ . This motion is so timed that this end of the lever is about to engage with the filling fork when the filling comes in contact with the prongs.

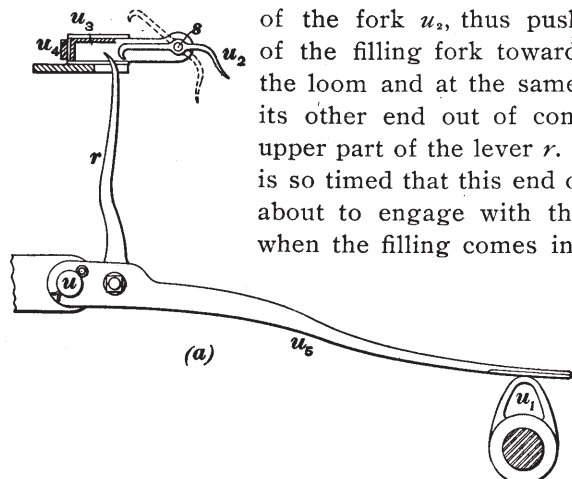

On the other hand, should the filling break or run out, the filling

fork will retain the position shown by the full lines in the figure, and the lever  $r$  in its forward movement, engaging with the filling fork, will carry it forwards together with the slide  $u_3$  to which the filling fork is attached.

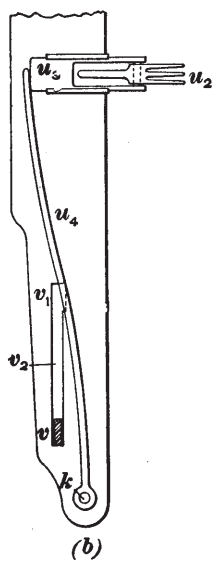

The other end of this slide is in contact with a lever  $u_4$ , pivoted at the point  $k$ . As the slide is brought forwards by the action of the lever  $u_5$ , it will bring with it the lever  $u_4$ , forcing this lever so strongly against the shipper handle  $v$  that the latter will be pushed from its retaining notch  $v_1$ , and will spring to the other end of the slot  $v_2$ , in which it works, thus causing it to occupy the position shown in Fig. 21 (b). This motion of the shipper handle

will ship the belt from the tight to the loose pulley and stop the loom.

FIG. 21

**BRAKE**

**34.** Without some special device for stopping the loom after the shipper handle is thrown out of its retaining notch and the belt shipped from the tight to the loose pulley, the loom would run for several picks owing to its great momentum. This difficulty is overcome by the use of the

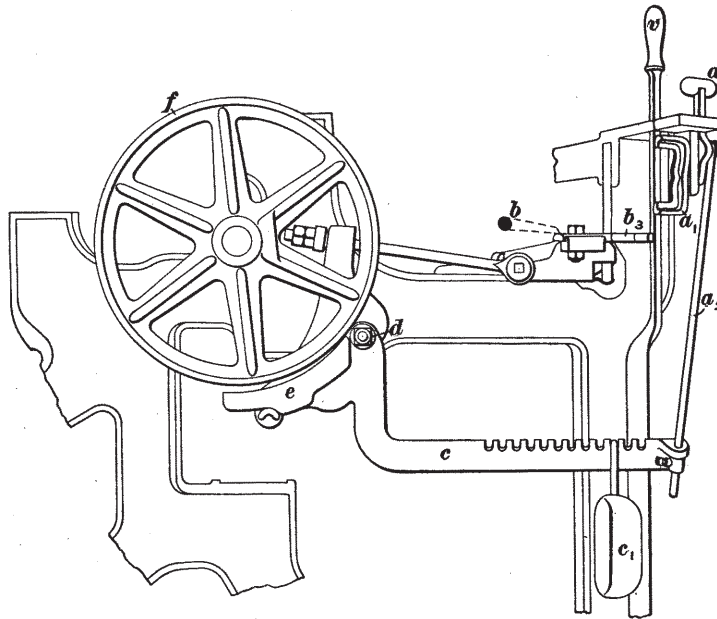

FIG. 22

**brake**, which will be found attached to every loom. Fig. 22 shows a common type of this mechanism.

On the ordinary plain loom, the shipper handle is automatically thrown out of its retaining notch under two conditions—when the filling runs out or breaks, and when the shuttle fails to enter either box properly. The manner in which the shipper handle is operated under the former condition has just been explained, and although mention has been made of the manner in which the dagger of the protector motion stops the loom when the shuttle is not boxed properly, this

part of the loom should be considered with reference to Fig. 22; *b* shows the dagger, which is also shown in Fig. 15. In case this dagger is not lifted by means of the shuttle pressing the finger of the protector motion outwards, it will engage with the steel bunter in the frog and press the casting *b*, against the shipper handle *v*, thus pushing the shipper handle from its retaining notch and stopping the loom.

In either case, when the shipper handle is released, it springs to the end of its slide, and in doing so operates the mechanism *a, a<sub>1</sub>* in such a manner as to lower the rod *a<sub>2</sub>*; *a, a<sub>1</sub>* is a simple crank arrangement so formed that the stud to which the rod *a<sub>2</sub>* is connected may be readily raised or lowered, thus raising or lowering the rod *a<sub>2</sub>*. As this rod is lowered it allows the weight *c<sub>1</sub>* to force the rod *c* downwards, which, being pivoted at *d* and carrying the brake *e*, will force the latter against the brake wheel *f* on the end of the crankshaft. When the belt is again shipped to the tight pulley by means of the shipper handle *v*, the entire mechanism is automatically restored to its original position, leaving the loom free to operate. In case it is desired to turn the crankshaft by hand, the brake wheel may be relieved of the action of the brake by simply moving the handle *a*.

---

### LOOM TEMPLES

**35.** The object of a pair of **temples** is to hold the cloth out as wide as possible during the process of weaving, and also to prevent the warp being drawn in or condensed at any part by the drag of the filling. The strain on the warp is so great that it is impossible to keep the cloth at the temple as wide as the space occupied in the reed. Good temples will, however, keep the cloth as near this width as is necessary. They are made in a variety of ways, but the temple consisting of a trough and roller is the most common.

Fig. 23 shows a sketch of a temple very largely in use, and Fig. 24 shows its parts; *a* is the base plate, which is screwed to the breast beam of the loom. To this are screwed the



stand  $a_1$  and cap  $a_2$ , which contain a spiral spring. The part  $b$  has a long shank that is enclosed in  $a_1, a_2$ . The shank works inside the spring, being provided with a shoulder to keep the spring in its place. The parts  $b_1, c$  enclose the roll  $d$ . A spindle passes through the roll and holds it in position, at the same time allowing it to revolve freely. This roll is usually made of wood, with small pins set in such a manner that they incline toward the edge of the cloth. The cloth in being woven passes between the part  $c$  and the roll  $d$ ; consequently, as the cloth is wound down it turns the roll  $d$ , and is

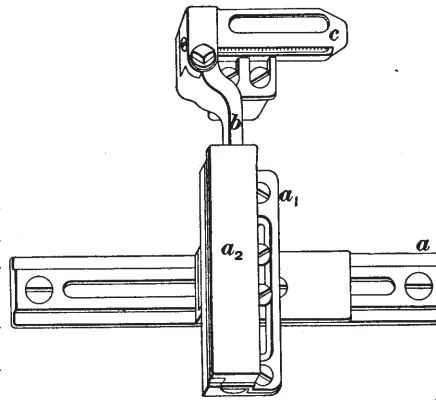

FIG. 23

as the cloth is wound down it turns the roll  $d$ , and is

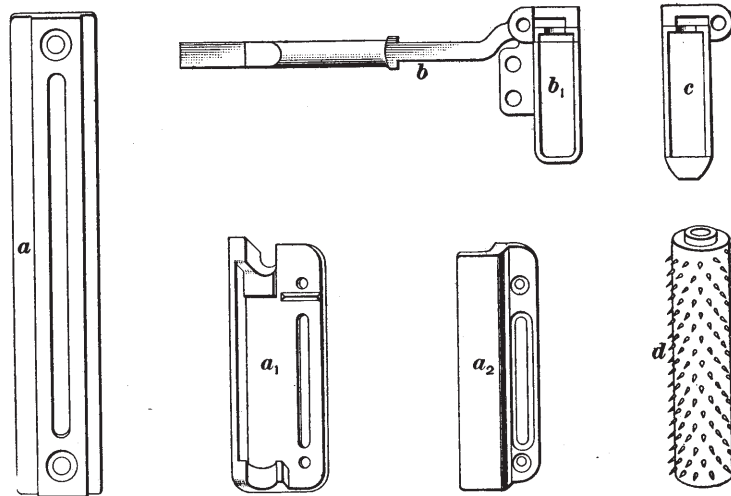

FIG. 24

distended to its full width through the inclination of the small pins.

### SHUTTLE GUARD

**36.** Serious accidents sometimes occur in the weave room, due to the shuttles flying out of the loom. To prevent this as much as possible, there is fastened to the reed cap a device known as the **shuttle guard**. It consists, generally, of a wire rod  $k$ , Fig. 12, extending across the front of the reed cap and projecting over that part of the race plate on which the shuttle travels, so that if the shuttle rises it will strike this rod, and either be turned into the yarn again or run over the yarn until it strikes the opposite box.

This rod makes it inconvenient for the weaver to draw in broken ends through the reed; consequently, some loom builders provide their looms with a wire rod or metal strip that can be turned up and laid flat against the reed cap, thus putting it out of the way of the weaver when drawing in ends. The weaver puts it in place again before starting the loom.

---

### LEASE RODS

**37.** Between the harnesses and the whip roll of the loom are placed what are known as the **lease rods**. The object of these rods is to separate the ends so as to prevent any entangling that might otherwise result. They also enable the weaver to piece up broken ends.

Lease rods are of two sizes, the smaller being placed in front. They are made of material that will stand the friction of the ends without having a groove cut in them, usually being made of tin, or of wood covered with varnish or black enamel.

---

### PULLEYS

**38.** There are two kinds of driving **pulleys** in common use on looms today; namely, the **tight-and-loose pulleys**, where the belt is shifted from one to the other, and the **friction pulley**. The tight-and-loose pulleys are found mostly on the plain loom, since they are the least expensive

and are more easily kept in repair, and for cotton looms on light and medium goods answer the purpose.

The friction pulley is more commonly found on heavy work, since it more readily imparts the speed to the loom; while with the tight-and-loose pulley at least one pick must be run before the loom will reach its full speed. Looms may be belted from above or from below.

**39. Power Necessary to Drive a Loom.**—The power to drive a loom is variously estimated at from  $\frac{1}{8}$  to  $\frac{1}{2}$  horsepower. A very wide loom weaving coarse goods, necessitating the use of a large shuttle and great tension on the warp, absorbs more power than a narrow loom on light goods. Looms equipped with dobbies or box motions absorb more power than plain looms.

Tests made have resulted as follows: Plain looms 30 inches wide on goods of light sley and pick, yarns averaging 70s, were operated with  $\frac{1}{7}$  horsepower; 30-inch looms running 150 picks per minute on heavy goods, absorbed  $\frac{1}{3}$  horsepower; 30-inch looms on standard drills running 180 picks per minute, averaged three and one-half looms to a horsepower. For general purposes about four looms to 1 horsepower is a safe estimate.

**40. Space Occupied.**—The space occupied by a 40-inch loom is  $7' 7\frac{1}{2}'' \times 3' 8''$ . This is for a loom that has a lay  $87\frac{1}{2}$  inches over all, a reed space of 48 inches, and will weave 44-inch cloth.

---

#### CALCULATIONS

**41.** There are but few calculations required in connection with the plain loom. The first is regarding the speed of the loom. This is always figured in picks per minute, and corresponds in almost every loom to the number of revolutions that the crank-shaft makes per minute.

The crank-shaft in most looms carries the driving pulley, which receives motion from the weave-room shaft, and, consequently, if the revolutions of the crank-shaft are obtained, the answer gives the number of picks per minute.

The principal calculation in connection with the plain loom is with regard to the take-up motion. The picks per inch that are inserted in the cloth depend on the rate at which the sand roll is driven forwards, taking up the cloth as it is woven. There are innumerable styles of take-up motions, although in general principles they are almost all alike, the difference being in the number of gears and in the diameters of sand rolls.

To determine the driving and driven gears of the take-up motion when calculating the change gear, always commence with the sand roll, which in all cases is considered as a driver. To find the change gear to give the number of picks required when it is a driver, apply the following rule:

**Rule I.**—*Multiply the driven gears together, and divide by the drivers, circumference in inches of sand roll, and picks per inch required.*

To find the change gear when it is a driven, apply rule II:

**Rule II.**—*Multiply the driving gears, circumference in inches of sand roll, and picks required together, and divide the result by the driven gears.*

To find the constant of a take-up motion, apply rule III:

**Rule III.**—*Multiply the driven gears together, and divide by the drivers and circumference in inches of sand roll, leaving change gear and picks per inch out of the calculations.*

*When the change gear is a driver, the constant will be divided by the picks per inch to obtain the change gear.*

*When the change gear is a driven, the picks per inch required will be divided by the constant, in order to obtain the change gear.*

In obtaining the change gear for a take-up motion, a certain percentage is generally taken from the actual measurement of the sand roll to allow for any contraction that takes place in the length of the cloth after it is taken from the loom. About 2 per cent. will cover all cases, although different builders allow different rates.

In figuring the change gear for a loom, it is always necessary to notice what part of the loom is working the pawl

that drives the ratchet wheel. It will be remembered that the cam-shaft revolves only once while two picks are being placed in the cloth; consequently, if the take-up motion is driven from the cam-shaft, it will operate but once in two picks. On this account, it is necessary when figuring change gears that are driven from the cam-shaft, to multiply the number of teeth in the ratchet wheel by 2.

When the take-up motion is driven by any part of the loom that operates every pick, such as the lay sword, the ratchet wheel is figured with its exact number of teeth.

EXAMPLE 1.—Find the change gear necessary to give 64 picks per inch with the take-up motion shown in Figs. 19 and 20, considering  $g_4$  as the change gear.

SOLUTION.—The ratchet gear  $g_1$  is driven from the cam-shaft and, consequently, will be considered as a gear of double the number of teeth that it actually contains. Deducting 2 per cent. from the circumference of the sand roll gives 14.21 as the circumference to be used when figuring for the change gear. The change gear  $g_4$  is a driver; therefore, applying rule I,

$$\frac{48 \times 27 \times 200}{14.21 \times 16 \times 64} = 18\text{-tooth change gear. Ans.}$$

EXAMPLE 2.—Find the change gear necessary to give 56 picks with the take-up motion illustrated in Fig. 20, considering the gear  $g_3$  as the change gear.

SOLUTION.—The change gear  $g_3$  is a driven gear; therefore, applying rule II,

$$\frac{16 \times 16 \times 14.21 \times 56}{48 \times 200} = 21\text{-tooth gear necessary. Ans.}$$

EXAMPLE 3.—Find the constant for the take-up motion illustrated in Fig. 20, considering the gear  $g_3$  as the change gear.

SOLUTION.—Applying rule III,

$$\frac{48 \times 200}{14.21 \times 16 \times 16} = 2.639, \text{ constant. Ans.}$$

42. To find the production of a loom, apply the following rule:

Rule.—*Multiply the number of picks per minute of the loom by the number of minutes in 1 hour and by the number of hours, and divide by the number of picks per inch being inserted in the*

*cloth, and then by the number of inches in a yard. Deduct from this an allowance for stoppages.*

The allowance for stoppages varies according to the class of goods being woven, but it is usually assumed that 10 per cent. is sufficient on ordinary plain cloth.

EXAMPLE.—A loom runs 180 picks per minute, 58 hours per week, and the cloth contains 64 picks per inch. The loom runs 90 per cent. of the possible time. Find the number of yards produced in a week.

SOLUTION.— 180 picks per min.  $\times$  60 (min. in hr.) = 10,800 picks per hr.  
 10,800 picks  $\times$  58 (hr. per wk.) = 626,400 picks per wk.  
 $626,400 \div 64$  (picks per in.) = 9,787.5 in. per wk.  
 $9,787.50 \div 36$  (in. in 1 yd.) = 271.87 yd. per wk.  
 90 per cent. of 271.87 = 244.6830 yd. Ans.