

# THE LOOM AND SPINDLE: PAST, PRESENT, AND FUTURE.<sup>1</sup>

By LUTHER HOOPER.

[With 11 plates.]

## I. PRIMITIVE LOOMS: PREHISTORIC, ANCIENT, AND MODERN.

The spindle and the loom, the one for twisting fiber into thread and the other for weaving the thread itself into cloth, are prehistoric and almost universal tools.

These tools, and the methods of using them, have never been subject to much variation, whether invented by prehistoric man, the skillful weavers of the ancient world, or the ingenious craftsmen of the primitive tribes of to-day.

Moreover, it is not only in elementary forms of weaving that this similarity is found, for if the essential principles of the most modern spinning and weaving machinery be investigated, it will be seen that they are identical with those used in the most ancient times. The complicated textile machinery of to-day is, therefore, simply a natural development from that used by primitive weavers of all time.

In the present course of lectures my intention is to demonstrate the principles of the primitive loom and spindle, and trace their gradual development into the wonderful, but still far from perfect, mechanism of the modern machines actuated by steam power; also to indicate the lines along which textile machinery, in the future, is likely to be improved.

In this first lecture I shall occupy the time at my disposal by a description of primitive spinning and weaving appliances, prehistoric, ancient, and modern.

Prehistoric examples of the weaver's art are extremely rare. This is owing, of course, to the perishable nature of the materials of which they are composed. Few as they are, however, and consisting, as they do, of the merest shreds of textile fabrics, they show unmistak-

<sup>1</sup> Canton Lectures delivered before the Royal Society of Arts, London, February 26, March 4 and 11, 1912. Reprinted by permission from *Journal of the Royal Society of Arts*, September 6, 13, 20, 1912.

A large number of the illustrations are taken from Mr. Hooper's "Hand-Loom weaving" and are reproduced by the courtesy of the publisher, Mr. John Hogg.

ably that the art of the loom, as well as that of the spindle and needle, was understood and successfully practiced in what has been poetically called by an eloquent French writer "The night of time."

The term "prehistoric" has, of course, only a relative meaning. Roughly speaking, history begins at the period in human development when the use of metal for tools and ornaments supersedes that of stone. I believe I am right in stating that antiquities of the Age of Stone are classed as belonging to prehistoric time.

It is generally agreed that most of the lake dwellings of Switzerland, which were discovered and eagerly investigated during the last century, belong to the neolithic, or later stone period. It was amongst the remains of one of the earliest of these villages, discovered in the bed of the lake at Robenhausen, that bundles of raw flax fiber, fine and coarse linen threads, twisted string of various sizes, and thick ropes, as well as netted and knitted fabrics and fragments of loom-woven linen cloth, sometimes rudely embellished with needlework, were found. There were also spindle whorls and loom weights of stone and earthenware, one or two fragments of wooden wheels, which might have formed parts of thread-twisting machines, as well as rude frames which were possibly the remains of simple looms.

It is remarkable that these relics of primitive weaving were found in the lowest of three villages, which, during successive ages, had been built on piles on a common site near the margin of the lake. The linen shreds bear evidence of having been partially burned, and they were found very deeply buried in the clay which forms the bed of the lake. It has been supposed that this early village was destroyed by fire, and that to this accident we owe the preservation of the precious relics. All traces of actual textile fabrics are absent from the later villages, although loom weights and spindle whorls are found in them all.

This theory of accident may be true or not, but however the partially burned specimens of flaxen materials became embedded and preserved, they demonstrate that the people of the stone age in Europe cultivated flax and hemp, prepared and spun the fibers into continuous thread, doubled and twisted it into various thicknesses for different uses, and netted, knitted, or wove it into fabrics of a sort which required a good deal of ingenious contrivance for their production.

Keller's work on the lake dwellers of Switzerland is illustrated with a large number of lithographic drawings. I have had a few of these photographed, as they show the construction of the textiles more clearly than photographs of the actual discolored fragments of cloth and thread would do.

[Photographs of illustrations from Keller's "Lake Dwellings of Switzerland," Longman, 1892, were here thrown on the screen.]

Discoverers of such relics as these are often apt to exaggerate in their imagination the attainments of the people who produced them. Thus, Prof. Messekommer, who in 1882 was fortunate enough to find the most important and probably earliest of the lake dwellers' villages at Robenhausen, as already described, says that "he is convinced, from the specimens of textiles there found, that all manner of weaving was thoroughly known at the very beginning of the lake-building period." An expert examination of these fragments, however, does not bear out his assumption. They are, as we have seen, all webs of the very simplest kind, and are just such as are woven by savage people of to-day, by means of the most elementary weaving appliances. No traces of tools for textile work were found beyond whorls for spindles, one or two charred spindles with thread wound on them, sharp-toothed combs, which were probably used for preparing the raw fiber, and a few weights of earthenware, similar to those which were used by the Greeks and Romans for weighting the warp threads of their upright looms.

In reconstructing the life and operations of ancient and prehistoric man from the scanty relics which are available, it is most reasonable to imagine that weaving, and in fact work of all kinds, was carried on with the maximum of human craft and patience and the minimum of mechanical contrivances. We should not imagine how quickly and easily things might have been made, but how simply, even though with infinite pains, the work could have been done.

Bearing this in mind let us examine two interesting relics of the handiwork of a prehistoric weaver shown in figure 1.

These are not, like so many of the fragments, netted or knitted from a single thread. This is proved by the regular and flat interlacement of its strands, which cross each other at right angles. How-

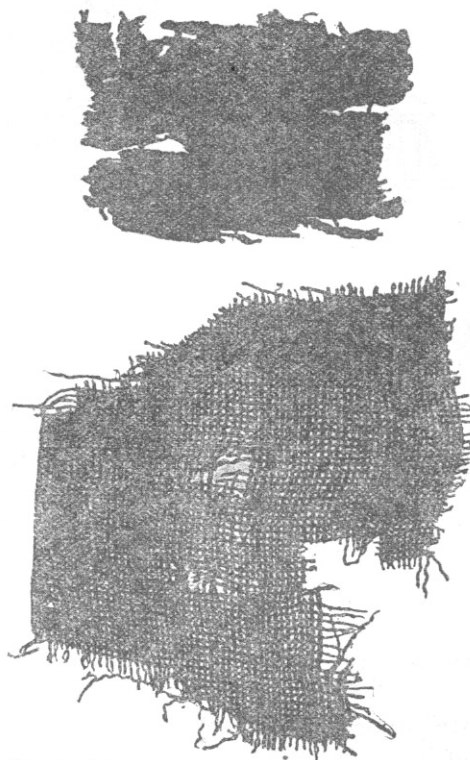

FIG. 1.—Fragments of linen cloth, woven by the prehistoric lake dwellers of Switzerland.

ever small the original webs may have been, a set of threads—the warp—must in each case have been stretched on some kind of frame. The intersecting threads—the weft—must also have been passed before and behind alternate warp threads in regular sequence. This could only have been done on a loom, however simple, and how simply a loom may be constructed let me exemplify.

Here is an oblong board, two sticks, and a piece of string.

If I wind the string onto the board (fig. 2) and insert the two sticks between alternate cords at one end, I have made the board and sticks

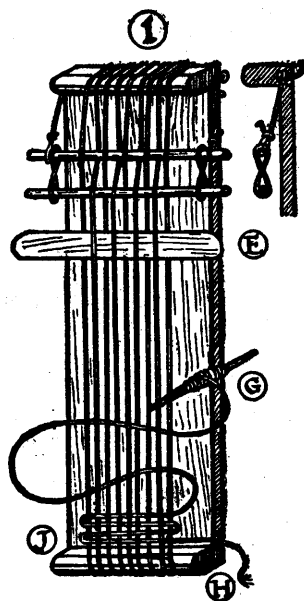

FIG. 2.—Primitive board loom and shed sticks.

and of all time. It is typical because it has the essential characteristic of all looms, which is the crossing of the threads between the sticks. This cross transforms a collection of any number of separate strings into a well-ordered weavable warp, which can easily be kept free from entanglement. In fact, without it no weaving could begin, much less be carried on to any length.

There is a roll of East African weaving in the ethnographical gallery of the British Museum. This beautiful strip of cloth is 4 inches wide and is a fine specimen of modern primitive weaving. The pretty web, with its delicate pattern of checkers, could quite easily be woven on such a board as this, no other appliances being necessary than the two or three sticks and a long thin spindle or needle for inserting the weft thread.

Here is a tiny board loom, on which I have had woven a copy of one of the border stripes of the African native web. Figure 3 (pl. 1) is a photograph of it.

You will notice a number of loops hanging loosely to the unwoven threads. I need not refer to them just now, except to say that they are for the purpose of economizing time and facilitating the work. Without them the weaving would take longer and require a little more attention, but otherwise could be as well done.

If we take a piece of loom-woven coarse canvas and examine it, we shall see clearly the stretched threads of warp and the continuous intersecting thread of weft. If a small fragment of such a piece of textile had been partially burnt and buried in clay at the bottom of a lake for 3,000 years or more, then, discovered by a fortunate arche-

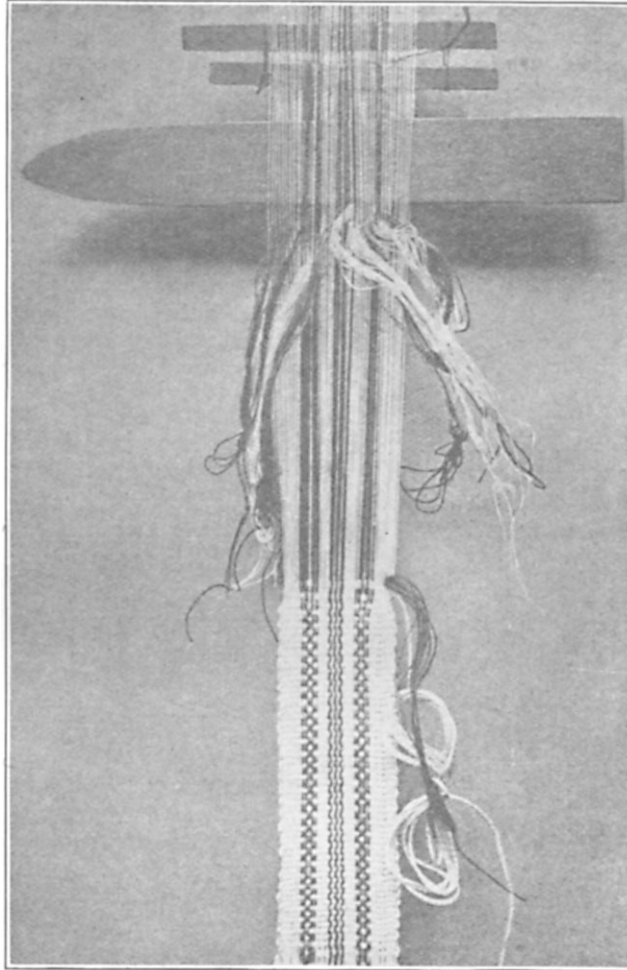

FIG. 3.—COPY (IN PROGRESS) OF A PORTION OF AN EAST AFRICAN WEB.

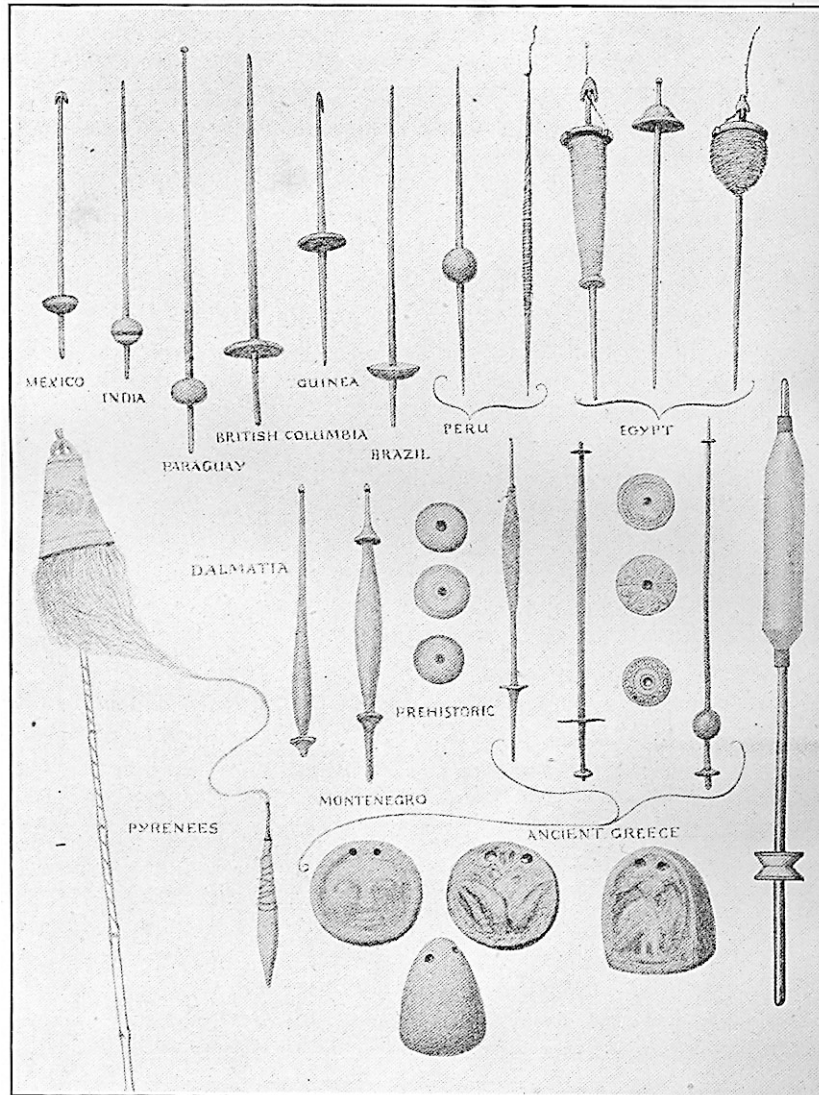

FIG. 4.—A COLLECTION OF PRIMITIVE SPINDLES, A DISTAFF, AND SOME LOOM WEIGHTS FROM VARIOUS COUNTRIES.

(Drawn by the author.)

ologist, had been pressed between two glasses for preservation in a museum, it would, I think, when photographed present very much the appearance of the shred of lake dwellers' linen cloth (fig 1).

I can best illustrate the method of intersecting warp and weft on my extemporized primitive loom.

[Here the lecturer gave a demonstration of the simplest kind of weaving.]

Before proceeding to inquire into particulars regarding the form of loom used by the lake dwellers, it will be advisable to make a digression in order to describe the art of making thread, which naturally precedes the art of weaving.

There is no natural continuous thread except silk, all others being artificial. Silk is unwound from the cocoon of the silkworm in lengths of from 500 to 1,000 yards.

Of this thread primitive man is unaware. But he seems to have an instinct which teaches him that various vegetable and animal fibers, however short they may be, can be twisted together and joined up into threads of any required length and thickness, as well as of great strength. Weaving is well nigh universal, but even in the few places where it is unknown the art of making very perfect thread and netting it into useful fabrics is commonly practiced.

The process of making thread may be stated very briefly. It consists of (1) stripping and cleaning the fibers; this is called *skutching* or *ginning*. (2) Of loosening and straightening out the cleansed fibers; this is termed *carding*. (3) Of drawing the carded filaments out in an even rove and twisting them together into fine or coarse continuous thread. This final process is called *spinning*.

The arts of spinning and weaving have acted and reacted continually on one another. This was notably exemplified during the eighteenth century in this country. At the beginning of the century weavers were often hindered by having to wait for yarn to weave, the domestic system of spinning by hand not being sufficient to keep pace with the production of cloth. This led to the invention of spinning machinery. By means of this machinery the output of yarn soon became greater than the hand-loom weavers could cope with, although there was still a growing demand for textile fabrics. The application of steam power to the loom and many improvements added to the loom itself increased the speed of weaving and again equalized the output of the two industries.

There can be no good weaving without good spinning, for good cloth can not be made of bad thread. Spinning can be done slowly, of course, without any mechanical aid whatever.

Here is a bundle of fiber ready for spinning. It has been simply cleaned and carded. If I draw out a few fibers and, after slightly damping them with clear water, twist them together with my fingers,

you will see that they have been converted, simply by the twisting, into a strong thread. Thread thus casually made is naturally coarse and rough, but an expert spinner would make in the same way a fine, strong, even thread with very few fibers.



FIG. 5.—Peasant spinning. (Present time.)

If a small stick, having a hook at one end and a weight at the other, be suspended to the spinning thread, the further even twisting of the yarn will become much easier, because regulated by the continuous revolution of the weighted stick or spindle, as such an appliance is called. The spindle is also useful for winding the twisted or spun thread upon.

Figure 4 (pl. 2) shows a collection of primitive spindles, both ancient and modern. A moment's consideration of it will show how widely distributed and well-nigh universal this simple industrial implement has been. One great advantage the spindle has over all other spinning appliances is that it can be carried about by the spinner without her

having to discontinue her work. An ancient story by Herodotus illustrates this point.

King Darius chanced to see a Pæonian woman who was carrying a pitcher on her head leading a horse and spinning flax. He sent spies after her, and they reported that she filled the pitcher with water, watered the horse, and returned, continuing all the while to spin with her spindle. Darius asked if all the women of Pæonia were so industrious; and being told they were, ordered that all the Pæonians, men, women, and children, should be removed from their own country into Persia.

Whether this reward of merit was appreciated by the Pæonians Herodotus does not say.

There is a painting on a Greek vase of about 500 B. C. which depicts a spinner holding the distaff in a picturesque and graceful but unusual and, one would think, ineffective way.

Figure 5 shows the usual method of carrying the distaff, which, it will be seen, leaves both hands of the spinner free for drawing out the fiber and twisting the spindle.

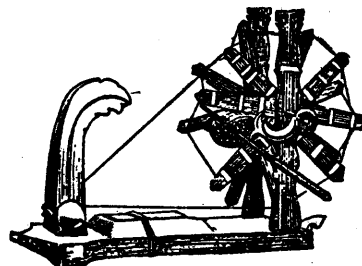

FIG. 6.—Native spinning wheel. (From Sarawak.)



Figure 6 is from Roth's "Natives of Sarawak" and shows the spindle attached to a small wheel, actuated by a large one, which keeps it regularly rotating.

With this wheel, as with the weighted spindle, twisting and winding on are alternate operations. The manner of using the wheel is as follows: The thread is first tied to the spindle, a convenient length of fiber being drawn out. The spinner turns the large wheel, which causes the spindle to revolve and twist the length of fiber, the latter being held in a line with the spindle. When sufficient twist has been given to the thread, the spinner adroitly moves the hand holding it so that the thread is brought at right angles with the spindle. The rotation of the wheel being continued in the same direction, the length of spun thread will be quickly wound upon the spindle. These alternate movements are repeated until the spindle is conveniently filled up with spun thread.

Spinning wheels working on this principle are widely distributed. They are still used in China and Japan and various countries of the East; also in Central America, as well as in many remote islands where native textile arts still survive. The large spinning wheel, still used in parts of Ireland, Wales, and Scotland for spinning wool, works in this manner. In Scotland it is called the muckle wheel.

Spinning with a wheel may have been practiced in Europe in ancient times, but there is no evidence to prove it. The thread is the same whether spun with or without the help of a wheel. The best and finest workable thread ever produced has been spun in India by means of the spindle, at Dacca, where the famous Dacca muslins are still woven by hand from hand-spun thread.

The well-known ordinary spinning wheel, sometimes called the Saxony or German wheel, has been in use since the sixteenth century. It has an ingenious arrangement by means of which the two operations of twisting the thread and winding it are done simultaneously. As, however, it carries the art of spinning beyond the primitive stage, I must leave its description to my next lecture.

After this rather lengthy but necessary digression we may resume the inquiry as to the loom in its ancient and primitive form.

The presence amongst the textile relics of the lake dwellers of a few circular and conical-shaped objects of stone and earthen ware, gives a clue to the form of loom on which the prehistoric webs were woven. Such objects, pierced with holes and sometimes elaborately ornamented, are found in excavations all over Europe. These objects are precisely like the weights which the Greeks and Romans and other ancient European peoples used for the purpose of stretching the threads of warp in their peculiarly constructed upright looms. (See fig. 4, pl. 1.)

Seeing, then, that similar objects to these are found amongst the lake dwellers' relics, it is reasonable to conclude that they were used for the same purpose, and that the form of the prehistoric loom was the same as that of the looms of a later period of which we have representations.



FIG. 7.—Greek loom. (From Boeotian vase painting. 500 B. C.)

Amongst the vase paintings of ancient Greece only four representations of the loom are found. Two of these are rough though expressive caricatures painted on Boeotian pottery. The loom in each of these sketches is very definite and, as far as it goes, evidently correct in detail. One of these painted pots is in the Bodleian Museum at Oxford, and the other, of which I have a photograph, is in the British Museum.

The subject of the painting is Kirke presenting the noxious potion to Odysseus (fig. 7).

The loom is simply a pair of upright posts with a cross-piece joining them together at the top. Beneath the cross-piece is a roller or beam on which the cloth is wound as it is woven. The unwoven warp is seen hanging nearly to the ground, where it appears to terminate in two rows of circular weights. These weights keep the



FIG. 8.—Penelope's loom. (From Greek vase painting. 500 B. C.)

warp threads taut, and two sticks intersect the threads in order to retain the cross between them alternately, so keeping the warp from entanglement and preserving an opening for the passing and interlacing of the weft. In the Oxford vase the weft is shown wound on a kind of mesh such as is used in the making of nets.

Figure 8 is copied from a beautiful Greek vase painting. Its date is about 500 B. C. This is a much more careful and elaborate painting, but it tells little more about the loom and its arrangement. The loom is of the same simple construction, but all the parts are more

carefully drawn and the pattern of the web—a highly ornamental one—is distinctly shown. There are also pegs on the top crosspiece of the loom on which spare balls of different-colored weft are kept handy for use. Spare warp was also probably hung from them at the back of the loom.

The weights at the bottom of the loom in this case are of a conical shape, very much like those found in Switzerland. There is also at the back of the loom another stick or beam, which is, I believe, for the purpose of holding the length of unwoven warp before it passes through the holes in the weights at the bottom of the loom. The loose back threads are not shown in the painting, but the roll of cloth upon the beam indicates that more than a loom's length of warp is being manipulated. Probably the artist shirked the difficulty of representing these back threads, and so made the front ones appear to terminate at the weights.

This painting is particularly interesting, because it shows unmistakably that the elaborate pattern webs, which the classic poets so often referred to, were woven on the simplest of looms by skillful handicraft, not by means of complicated machinery, as some have supposed. In proof of this, if you will notice the border of grotesque creatures which Penelope has just woven, you will recognize its likeness to the pattern on the robe of a processional figure, copied from another vase painting of the same period, which is the subject of figure 9.

On a tiny vase in the British Museum there is a slight sketch of a lady weaving on a small frame, which she holds on her lap.<sup>1</sup> In this case the strings of warp are merely stretched on the frame, and there are no loom weights. There is, however, a peculiarity in the method of working depicted which unmistakably links this diminutive loom with those of Kirke and Penelope, as we shall presently see.

Olaf Olafsen, in a work on Iceland, published in Amsterdam in 1780, gives an illustration and account of a traditional loom still used at his time in that country. There are two or three more or less imperfect copies of Olafsen's drawing in English books which show the striking points of resemblance this loom bears to the looms of ancient Greece.<sup>2</sup>



FIG. 9.—Processional figure. (From a Greek vase painting. 500 B. C.)

<sup>1</sup> Gallery of Greek and Roman life, B. M.

<sup>2</sup> One of these is an illustration to the article "Tela," in Smith's "Dictionary of Greek and Roman Antiquities."

Looms constructed in the manner which required the kind of weights found in the lake dwellings, those depicted in use on the classic vases, and the traditional looms of the north of Europe, all agree in requiring a method of weaving which differs from that of all other looms the world over. This peculiarity was noticed by Herodotus, who visited Egypt about 400 B. C., and recorded his impressions. Speaking of the Egyptians, who appeared to him to do everything in a contrary manner, he says: "Other nations"—meaning, of course, Europeans—"throw the wool upward in weaving, the Egyptians downward."

Now, if you will glance again at figures 7 and 8, after you have noted the point on the Icelandic one, you will see that the webs on these looms are all being woven from the top. This necessitates beating the weft upward as the Greek historian says, and also winding the cloth upon the top roller. In fact the method of stretching the warp by the hanging weights and the necessary relative position of the cross sticks make it impossible to weave in any other way.

The Greek lady weaving on a small frame I referred to is also shown commencing at the top, although in her case the warp being stretched upon a frame, it is not necessary to weave in what we should consider an awkward way; her doing so, however, shows that it was the custom to which she was used.

The people of ancient Egypt did a large export trade with Europe and distant parts of Africa and Arabia in manufactured linen, the fine linen of Egypt being unrivaled in the ancient world for evenness and fineness of texture.

Owing, no doubt, to the dryness of the climate of Egypt, and the peculiar funeral customs of the Egyptians, many specimens of ancient Egyptian textiles have been preserved. Linen cloth, which was woven four or five thousand years ago or even more, may still be seen and handled, being as perfect as when it was newly cut out of the loom by the industrious Egyptian weaver.

In the British and other museums many examples of such Egyptian linen textiles may be seen. These linen cloths were unwrapped from the mummies whose funerals took place under the various dynasties. As to the looms on which these textiles were woven, the few representations of them which exist show that they were constructed on a different plan from those of Europe, and bear out the statement of Herodotus that the Egyptians beat the weft downward instead of upward when weaving.

Only three pictures of ancient Egyptian looms are known to exist, and there seem to be no traces or fragments whatever of the looms themselves.

The drawings of Egyptian looms (figs. 10, 11, and 12) were made from wall paintings at Bene Hasan and Thebes in Upper Egypt.

Figure 10 is rather a puzzling one, because the artist has combined a bird's-eye view of the loom with a side elevation of the weaver. The warp, which is a short one, is simply stretched upon the ground. There are no rollers or loom frame of any kind. The weaver is making a carpet or mat, it may be of rushes or grass. The only distinct facts to be gathered from this drawing are that the weft is being beaten down and the web is growing upward; also that the warp is fixed at both top and bottom.

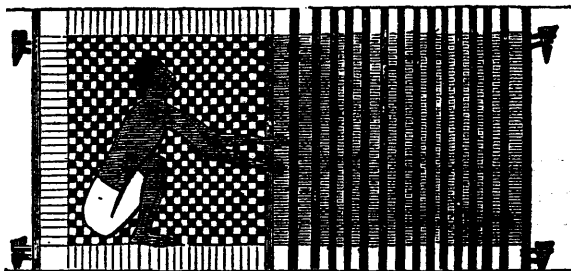

FIG. 10.—Egyptian loom and weaver.

In figure 11 two weavers work at a small upright loom. The weaver to the right is inserting a stick, with a hook at the end, into the warp. This hooked stick has been the subject of much discussion, but I believe it is really a spindle with the weft wound on it, the artist not being able or not having troubled to indicate the thread. Possibly he was an ancient post impressionist, and only represented symbols and souls of things, not their actual appearance or sordid detail.

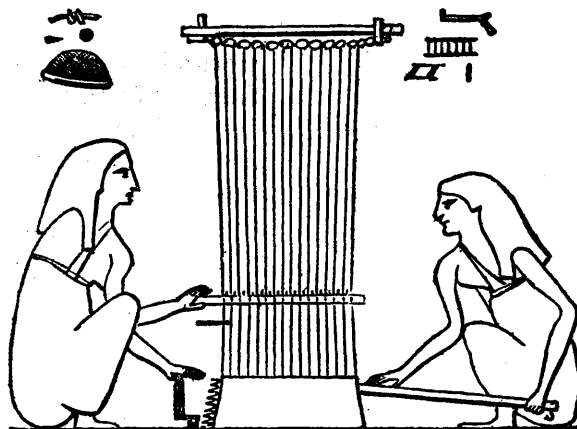

FIG. 11.—Egyptian loom in use.

growing upward. As the loom has no rollers either at the top or bottom, only a loom's length of material can be woven on it.

Figure 12 is a much more effective-looking loom than either of the foregoing, although there are many puzzling points about it. It has loom posts, and is evidently a solid structure. There are no rollers definitely shown, but they may well be there. The arrangement of sticks at the top may be intended to represent a skeleton roller, and the bottom one on which the cloth is wound as it is made may be hidden by the bench on which the very active weaver, wielding the

hooked stick, is at work. The cross sticks are shown, but their purpose could never be detected from the picture. There is not much indication—only a line—as to which is woven web and which unwoven warp. I imagine the line just above the weaver's knee is that of the already woven portion, and that all above is unwoven warp. Also that the line by the weaver's left hand indicates where he is picking up alternate threads to make an opening for the weft which is wound upon the hooked stick or spindle.

Anyhow, we have here the warp stretched between the top and bottom bars, or probably rollers, of an upright loom of solid construction

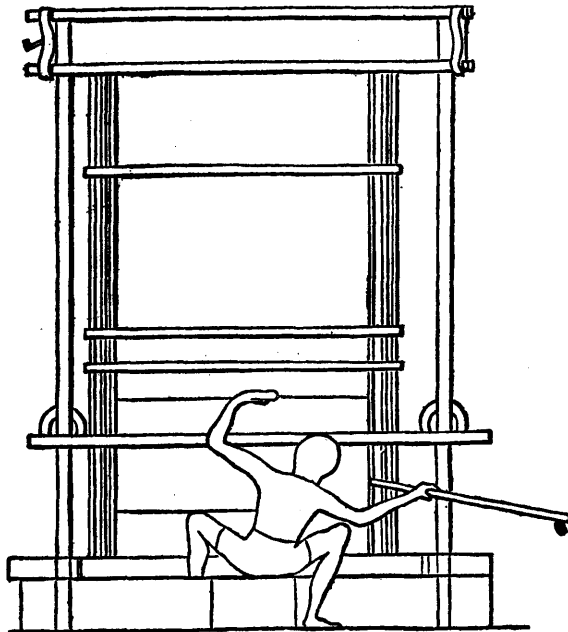

FIG. 12.—Egyptian loom for linen weaving.

at which the weaver is at work in such a position that he must be beating the weft downward, and the web be growing upward.

Fastening the warp at both ends to rollers and weaving upward are without doubt great advances on the ancient European methods of procedure. A further advance is the invention of what is now called the heddle rod. There is no direct evidence of this valuable addition

to the loom either in ancient Europe or in Egypt, but it is difficult to believe that the extremely fine wide linen of Egypt could have been woven to the extent it was, without this simple and obvious appliance. Some of the finest Egyptian webs have as many as 150 threads of warp to every inch of their width, and it seems incredible that this multitude of fine threads could have been profitably manipulated with the fingers only.

It is possible that the bar across the loom (fig. 12), on which the weaver is apparently only resting his arm, may be a heddle rod. This important appliance I must now explain.

Returning for a moment to figure 3, let me call your attention to the loose loops which I pointed out as time economizers, but did not further describe.

These loose loops are attached one to each thread of the warp, which is at the back of the lower cross stick. The cross stick makes one shed or opening for the weft. The loops, on being pulled forward, bring the back threads to the front, and so make the second or alternate opening.

You will see this at once if I add loops to my simple loom and insert a rod to enable me to raise them all together.

[Here the lecturer demonstrated the use of the heddle rod (fig. 13).]

As an appliance for two important branches of textile work—tapestry weaving and the weaving of hand-knotted pile carpets—the loom, at the point we have now reached, seems to be capable of no further development.

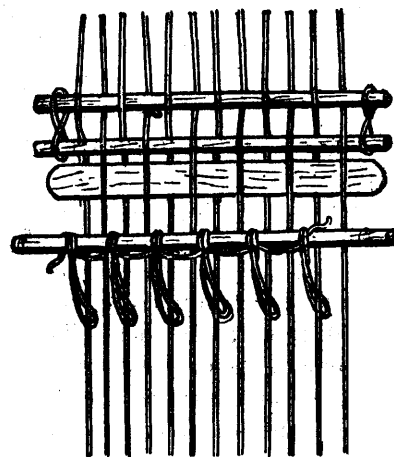

FIG. 13.—Loops and heddle rod.

Figure 14 is a design for a small tapestry loom from Mrs. Christie's "Handbook of Embroidery and Tapestry Weaving."<sup>1</sup>

This loom, simple as it is, can not be improved in its mechanism, except perhaps in some unimportant details, for the use of the artist weaver to work out his free designs upon.

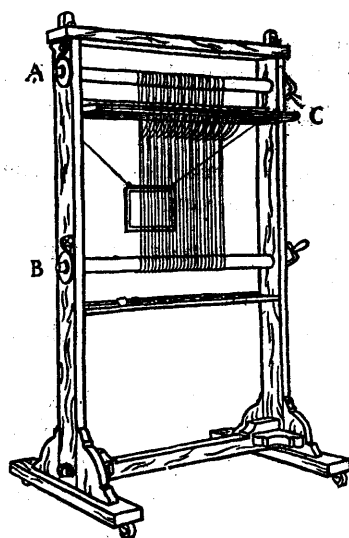

FIG. 14.—Tapestry loom.

All the gorgeous and more or less elaborately ornamented carpets of the East, as well as the exquisitely wrought tapestries of the West, from the most ancient times to our own, have been woven on looms of no more complicated construction than this. Added mechanical contrivances limit the scope of the craftsman. Freedom of design is trammelled in proportion to the facilities invented for the automatic repetition of pattern in the loom.

The six illustrations with which I conclude this lecture are taken from the masterpieces of weaving made on looms of no more elaborate construction than figure 14 at different periods by equally skilled craftsmen in various parts of the world.

Figure 15 (pl. 3) is the most ancient piece of ornamental tapestry weaving known to exist. It is extremely fine in texture, the whole

<sup>1</sup> "Handbook of embroidery and tapestry weaving," John Hogg, Paternoster Row.

piece being only 4 inches by 1½ inches in size. It formed part of the robe of Amenhilep III, who reigned in Egypt 2000 B. C. The original is in the Cairo Museum.

Figure 16 (pl. 3) is a piece of Greek tapestry of about 500 B. C. It was discovered in the relics of a Greek colony in the Crimea. The original is in the Hermitage Museum, St. Petersburg.

Figure 17 (pl. 3) is a fine piece of Egypto-Roman tapestry woven of colored silk unwoven from Chinese webs. The actual size of the little panel is 4 inches by 4 inches. It formed part of a child's tunic in the fifth century A. D.

Figure 18 (pl. 4) is a piece of Persian weaving of the sixteenth century. It may have been woven in Venice by Persian weavers. It is an exquisite example of hand-knotted velvet pile, there being as many as 400 knots to an inch. The color and ornamentation are superb. It is one of the choicest treasures of the Victoria and Albert Museum collection and is called the Persian cope.

The same museum possesses a set of Brussels tapestry of the sixteenth century. The figures are life size and are splendidly wrought. Figure 19 (pl. 4) represents a portion of one of the panels.

The subject of figure 20 (pl. 5) is a modern tapestry by Morris & Co. The design, "The Passing of Venus," was made by the late Sir E. Burne-Jones. The tapestry took seven years to produce and, being sent to the recent Brussels Exhibition, was destroyed in the disastrous fire which took place there, together with many other art treasures.

All these examples of tapestry weaving were made on such looms as figure 14 and are really mosaics of plain weaving with a loose weft.

Figure 21 (pl. 6) is a photograph of the tapestry-weaving workshop of Messrs. Morris & Co., at Merton Abbey.

In the next lecture I shall deal with spinning machines and the development of the loom for automatic pattern weaving.

## II. SPINNING MECHANISM AND THE LOOM FOR AUTOMATIC WEAVING, PLAIN AND ORNAMENTAL.

In the present lecture I shall first deal briefly with the spindle in its later development from the domestic spinning wheel of the sixteenth century to the machines of extraordinary capacity and exactness which supply the enormous quantity of yarn of all kinds required in the textile industries of to-day. This will clear the way for the further and more important study of the loom as used for automatic plain and ornamental weaving.

On the primitive spinning wheel, you will remember, I pointed out that the spinning of the thread and winding it on to the spindle were separate alternate operations. On the more modern spinning wheels the spinning and winding are made simultaneous by means



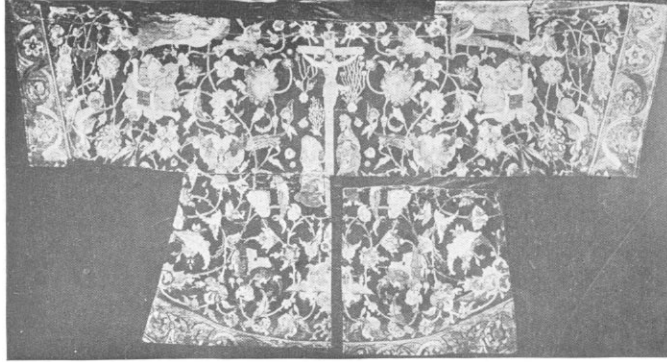

FIG. 18.—THE PERSIAN COPE.  
(Victoria and Albert Museum.)



FIG. 19.—PORTION OF A BRUSSELS TAPESTRY.  
(Victoria and Albert Museum.)



FIG. 15.—EGYPTIAN TAPESTRY.  
(Cairo Museum. 2000 B. C.)

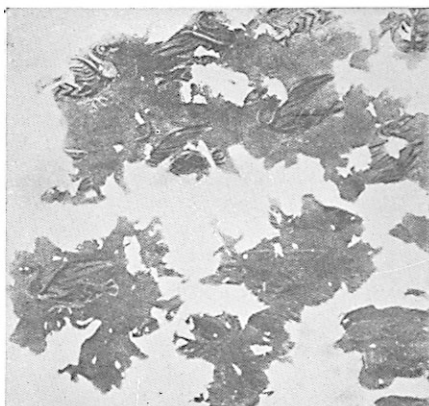

FIG. 16.—GREEK TAPESTRY.  
(500 B. C.)



FIG. 17.—EGYPTO-ROMAN TAPESTRY PANEL  
(Victoria and Albert Museum.)



FIG. 20.—"THE PASSING OF VENUS." MORRIS TAPESTRY.  
(Designed by the late Sir E. Burne-Jones.)



FIG. 21.—TAPESTRY WEAVING IN THE MERTON ABBEY FACTORY OF MESSRS. MORRIS & CO.

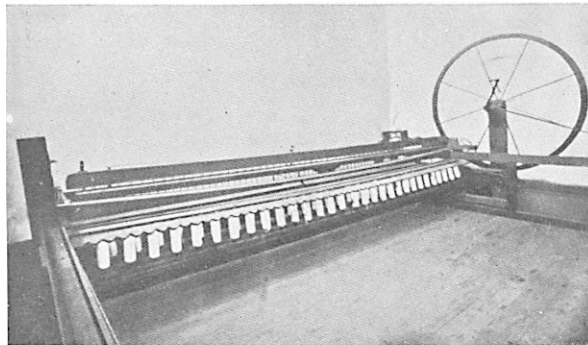

FIG. 23.—HARGREAVE'S SPINNING JENNY.

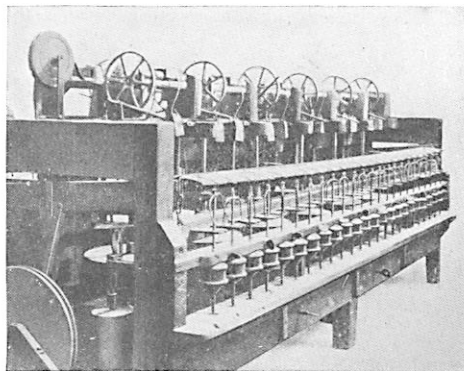

FIG. 24.—ARKWRIGHT'S WATER FRAME.

of a little contrivance called a flier and bobbin attachment to the spindle.

The first historic hint we have of this invention is from a drawing in one of the sketchbooks of the great artist-craftsman, Leonardo da Vinci. But it was not until nearly a century after his death, which took place in 1519, that the spinning wheel with this clever attachment came into general use.

Figure 22 shows Leonardo's drawing and the later spinning-machine attachments which have been derived from it.

In Leonardo's drawing No. 1 is called the flier. It is firmly fixed on the end of a shaft or spindle No. 2 A and 2 B. No. 3 is a small pulley also firmly fixed to the spindle between the bearings C and D. When this pulley is made to revolve very rapidly, by means of a cord or belt from a large wheel, the flier revolves with it and twists the thread which is passed through the hole in the spindle at No. 2 A.

No. 4 is another pulley, rather larger than No. 3. This pulley is fixed on a hollow shaft, which extends from the pulley to No. 5. In the hollow of this shaft, the spindle can freely revolve, and on it the bobbin, No. 6, tightly fits.

Now, if the different-sized pulleys, Nos. 3 and 4, be actuated by cords from the same large wheel, the flier will revolve at a greater speed than the bobbin, the difference in speed being, of course, in proportion to the difference in size of the pulleys.

The result of this arrangement will be that, if the thread, twisted by the revolution of the spindle, be passed through the eyes in the flier, as in the drawing, and fastened to the bobbin, two operations will take place: (1) The thread will be twisted by the flier; (2) because the bobbin revolves at less speed than the flier the thread will be gradually wound upon the bobbin.

No. 7 appears to be a kind of fork fixed to the end of the spindle. If this fork were pushed to the right the eye of the flier could be placed at any part of the bobbin, so as to spread the yarn evenly upon it.

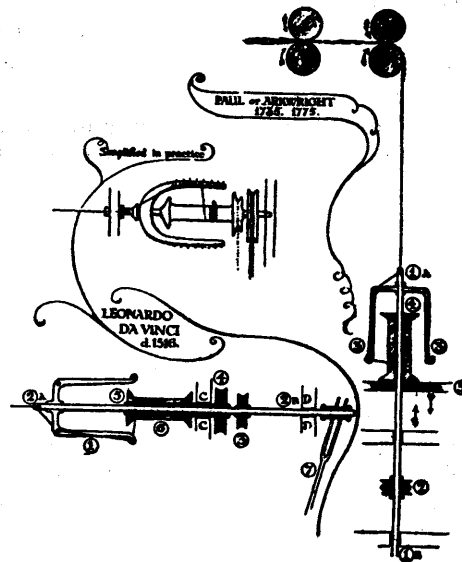

FIG. 22.—First drawing of bobbin and their attachment for spinning wheels.

Sooner or later this suggestion of Leonardo's was practically adopted, and the spinning wheel, fitted with bobbin and flier, came into general use in Europe. The distaff and spindle, however, have not, even to this day, been altogether superseded.

A more compact and convenient contrivance for spreading the spun thread upon the bobbin is shown above Leonardo's sketch. In place of the fork for altering the relative position of the flier and bobbin, a row of small hooks is placed along the arm of the flier, by means of which the thread can be guided on to the bobbin at any part of its barrel. This is the twisting and winding arrangement with which the improved spinning wheels of the seventeenth century in Europe were fitted up.

In order to compare it with Leonardo's sketch I have to the right of it (fig. 22) made a diagram of the bobbin and flier of a machine spindle.

It is old-fashioned now, as a modification of it, called the ring spinner, has taken its place. The principle on which it works, however, is the same, so, as it is more convenient to compare with the original sketch, I prefer to use it.

Here Nos. 1 A and 1 B indicate the spindle, which is caused to revolve by the pulley, No. 2.

The machine spindle is fixed vertically, a hundred or two being ranged on one machine.

The flier, No. 3, is fixed at the top of the spindle.

No. 4 is the bobbin standing on a shelf, No. 5. The shelf is made to rise and fall automatically as the thread is delivered to it from the flier. This is, therefore, a return to Leonardo's idea of the shifting spindle.

The spindle passes through the bobbin, but there is no hollow shaft for causing the bobbin to revolve. It simply stands loosely on the shelf, and when the thread from the flier is attached to it, the revolving flier drags the bobbin round at a less speed than its own, the weight of the bobbin acting as a brake. The thread is thus wound on more or less quickly, according to the weight of the bobbin.

In the ring spinner before mentioned the bobbin, or paper cop, is fixed firmly on the spindle and the flier is free. The flier runs on a ring which encircles the cop and drags upon it. This acts in the same way, as to winding, but makes it possible for the spindle to revolve at a much higher speed.

Although thus adopted for machine spinning, the idea of a loose bobbin was not, I believe, a new one. Spinning wheels had probably been previously fitted with loose bobbins, such as that shown in the diagram, above Leonardo's drawing. In this case the fixed flier is revolved by a pulley, which is connected by a belt to a large wheel. The loose bobbin, if not heavy enough to act as its own brake, has a

string which is lightly attached to some fixed part of the framework of the machine. This being passed over, the bobbin brake pulley can be easily made to regulate its drag to a nicety.

At the top of the diagram (fig. 22) are shown two pairs of rollers, between which the fibers to be spun are being drawn out with such regularity as few spinners could boast of. In a machine such rollers are set in a series, at very accurate distances apart, and revolved in the direction indicated by the arrows. The front pair of rollers revolve more quickly than the second pair; the second pair than the third, and so on. Consequently, as the fibers pass between the series, they are gradually drawn out into a fine fleecy rove which, between the front rollers and the spindle, becomes twisted into fine even thread.

This system of drawing out fibers by means of rollers was invented by Paul in 1735 and made practical by Arkwright in 1775, when he patented it. His right, however, was disputed, and on trial the patent was annulled, but his adaptation of the system was soon generally adopted.

When describing, in the last lecture, the primitive spinning wheel and the distaff and spindle, where the spinning and winding on were done alternately, I should perhaps have remarked that the finest threads were always produced in this manner. It is not surprising, therefore; that very early in the history of machine spinning it was found that very fine, delicate threads could not be spun on the simultaneous principle. To overcome this difficulty Crompton invented the mule machine, which imitates exactly the alternate twisting and winding of the primitive method of spinning. It was interesting to see at the Anglo-Japanese exhibition of 1909 the huge English machine of 250 spindles imitating with perfect precision the actions of a pretty girl in the Japanese handicraft section who was spinning gossamer thread on a primitive wheel, the same kind of wheel which had been in use in her country for a couple of thousand years or so, and which, we may hope, will be used for an indefinite number of thousands of years more by such charming little spinsters.

Messrs. Dobson & Barlow (Ltd.), of Bolton, have courteously sent me five photographs of spinning machinery of great interest, which will require little explanation.

Figure 23 (pl. 6) is Hargreave's spinning-jenny.

Figure 24 (pl. 6) is Arkwright's water frame, so called because he used water as a motive power to drive it. It combines the drawing rollers with the flier and bobbin attachment suggested by the spinning wheel then in general use.

Figure 25 (pl. 7) is Crompton's mule, which he used in secret for some time, and mystified his neighbors by the quantity and quality of the yarn he produced.

Figure 26 (pl. 7) is a full-sized mule spinning machine by Messrs. Dodson & Barlow (Ltd.), of Bolton, which works on the same principle as Crompton's mule and the Japanese girl I referred to just now.

Figure 27 (pl. 7) is a ring spinning machine, working on the principle of this Italian peasant spinning wheel—the driven bobbin and the loose flier.

[The lecturer here exhibited Italian and Belgian spinning wheels, having a driven bobbin and a loose flier, and demonstrated how similar effects were obtained (1) by a separately driven bobbin and flier, (2) a driven flier and loose bobbin, and (3) by means of a driven bobbin and a loose flier.]

In conclusion, as regards the spindle, although we may congratulate ourselves on the performances of these wonderful thread-making machines and admire the inventive genius which has brought them to such perfection, it is interesting, though perhaps chastening and humiliating, to note that the untutored Hindoo spinner, squatting on the ground with a simple toylike spindle, can draw out and spin thread as fine, but infinitely stronger, than the most perfect machine of them all.

I now resume the inquiry as to the development of the automatic loom from the point arrived at at the end of my last lecture.

Four thousand years ago, more or less, probably at the time when the people of the stone age in Europe were cultivating flax and spinning and weaving its fiber into coarse cloth, the Chinese were inventing improvements in their primitive weaving appliances in order to adapt them to the weaving of an infinitely finer fiber than that of flax. This fiber was obtained by unwinding the case of the chrysalis of the mulberry-feeding moth, the caterpillar of which is familiarly known as the silkworm.

Chinese continuous written history goes back to that remote period, and tells that the annual festivals of agriculture and sericulture, which are still observed by the Chinese, were instituted by an Emperor and his wife, who themselves took leading parts in the festival, the Emperor plowing a furrow and the Empress unwinding some silkworm cocoons. This practice their successors have continued to the present time.

This Empress is still highly honored in China, and votive offerings are made to her at the festival. She is held in great regard as the benefactress who taught the Chinese how to prepare the silken thread for use and to weave it, thus enabling them to become the best and richest clothed people in the world. This preeminence they have maintained owing to their original monopoly and expert knowledge of the cultivation and manipulation of the strongest, finest, and most lustrous of all threads now called silk.



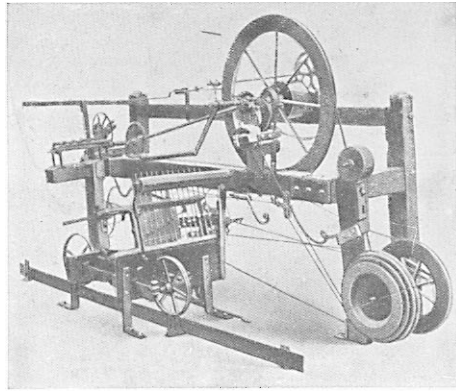

FIG. 25.—CROMPTON'S MULE.  
(Bolton Museum.)

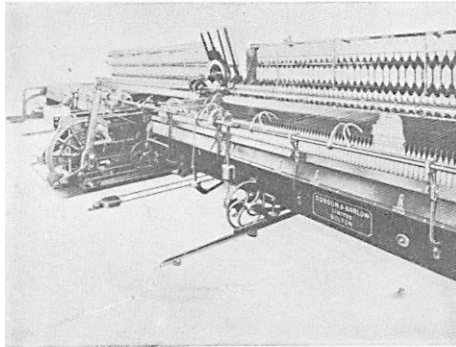

FIG. 26.—MODERN SPINNING MULE.  
(Dobson & Barlow, Ltd.)

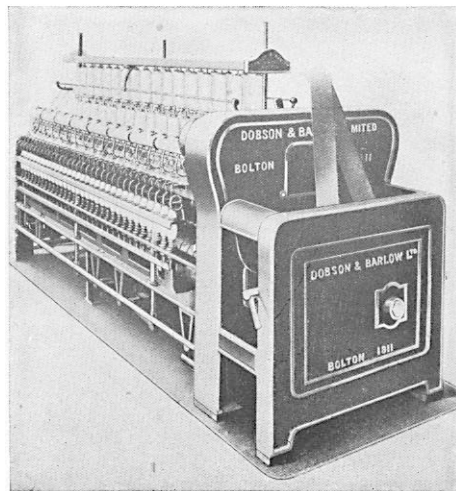

FIG. 27.—RING-SPINNING MACHINE.  
(Dobson & Barlow, Ltd.)

The silk fiber, on being unwound from the cocoon, is found to be a continuous, double thread of about the four-thousandth part of an inch in diameter. It takes from eighty to a hundred threads of natural silk to make up one thread of the size of the finest spun flax. It may be well understood, therefore, that special preparation of silk thread and specially delicate appliances are necessary for weaving it. This necessity proved to be, as is proverbially the case, the mother of many inventions, and there can be no doubt it is from the original Chinese weaving appliances that almost all succeeding improvements in looms and loom fittings have been derived.

In order to describe the improvements in the loom required for weaving fine silk, reference must be made to figure 28, which shows a primitive loom fitted with a heddle rod for the purpose of raising the threads of the warp alternately with those raised by the shed stick.

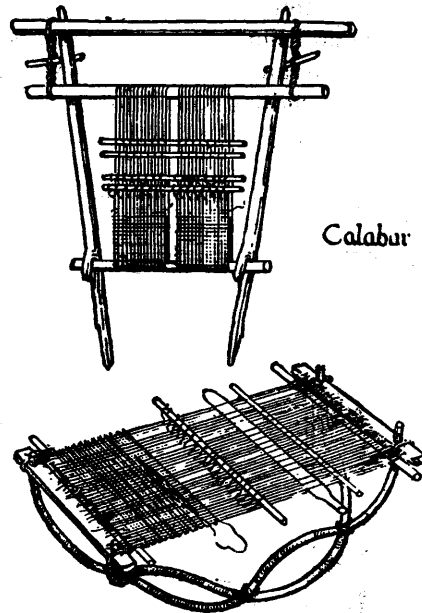

FIG. 28.—Primitive looms. (One fitted with two heddle rods.)

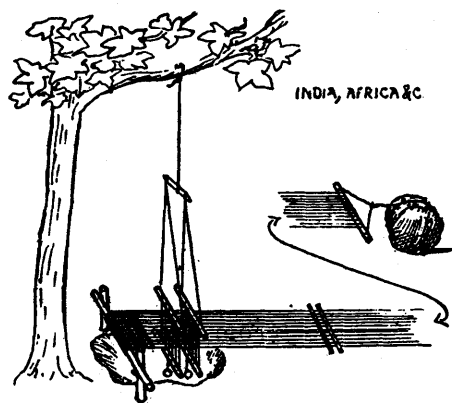

FIG. 29.—Primitive loom (India, etc.).

Two heddle rods in an upright loom would be no great, if any, advantage; but if the warp be placed horizontally, the manipulation of the successive openings for the weft is much more convenient for the weaver, who sits at the end of the warp instead of in front of it.

Figure 29 shows a very convenient form of Indian loom with the heddle rods suspended from the branch of a tree and having the heddle

loops connected with another pair of rods beneath the warp. The lower rods have strings hanging from them, each terminating in a ring. By placing one of his great toes in each ring the weaver can

pull down either set of loops at will and make alternate openings for the shuttle carrying the weft. His hands are thus left free to manipulate the shuttle.

The addition of a long comb, equal in length to the width of the warp, was an immense improvement to the loom. The divisions in it were originally made of split reeds, hence it was called the reed, and is still so called, although the divisions are now always made of steel.

The effect of the long comb, with the warp threads entered in it, swinging in its heavy frame (see fig. 30), was not only that the weft was beaten together more evenly and with less individual strain on the threads, but the width of the woven web was kept automatically the same.

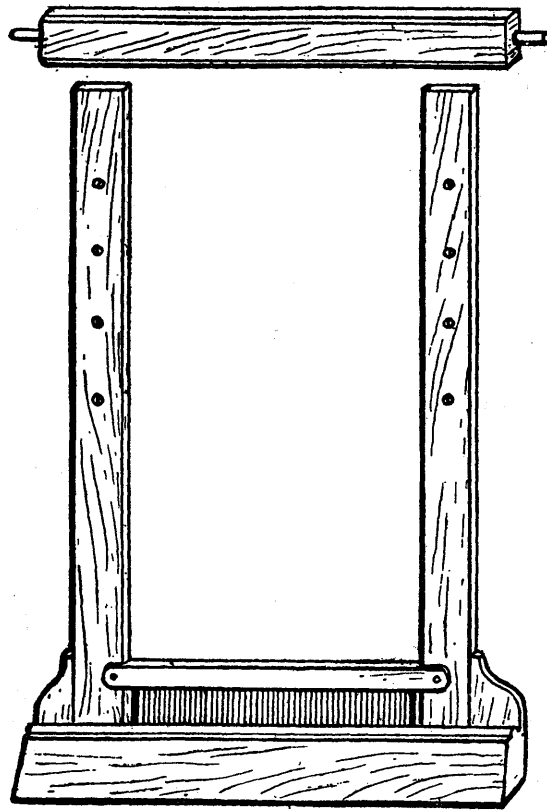

FIG. 30.—The reed fitted in its frame.

Figure 31 is a longitudinal section of the essential parts of a loom at the point of development now arrived at. It is lettered for reference. A is the roller on which the warp is wound in the first instance. B is the roller onto which the woven cloth passes. C C are the sticks preserving the cross which keeps the warp in order. D is one of two pulleys suspended from the top of the

loom frame, over which cords pass after being attached to the ends of the top laths of the two heddles. At E are two treadles which are tied to the lower laths of the heddles. Between the heddles and B the reed is shown suspended.

One treadle is represented depressed. This has pulled down one heddle and raised the other in consequence of the cord which passes over the pulley D. This movement has effected an opening in the

warp at F, which between the roller B and the reed is wide enough for passing the weft through.

The successful weaving of plain silk necessitates a development of the loom to this point. It is therefore reasonable to credit the Chinese, who until the third century A. D. were the monopolists of silk and silk weaving, with all these essential contrivances. Subsequently to the third century these inventions spread through the East generally and finally to Europe, first to Spain and Italy, then to France, Germany, and England. It is remarkable that the loom of to-day, on which the very best silk fabrics are woven, should in all essential points be the same as the looms of ancient China.

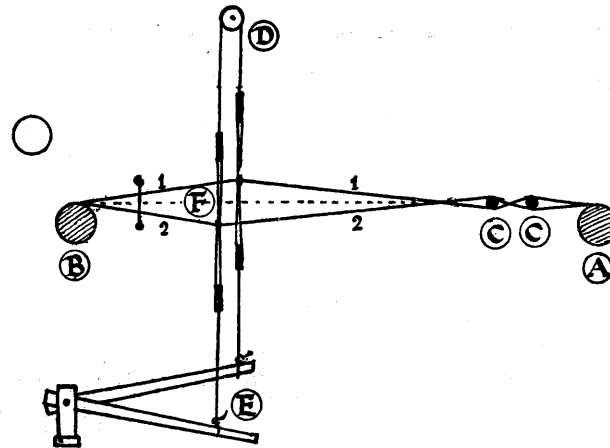

FIG. 31.—Section of opened warp.

Figure 32 (pl. 8) is from a sketch I drew from life in a Bethnal Green silk weaver's workshop a few weeks ago. The weaveress is making a rich black satin, which will be all but perfect when it is cut out of the loom, and will require no after artificial finishing to make it ready for sale. The loom is arranged in the simple manner described, except that as the weaving of satin requires more heddles than plain silk eight heddles instead of two only are shown.

The first impression given by figure 33, which is a diagram of an English loom, is one of sturdy strength. Strength and the perfect adjustment of the various parts of the loom are prime requisites where rapid and accurate weaving are desired.

Figure 34 (pl. 8) is from a manuscript of the fourteenth century and represents an English silk weaver of the period at his loom. Whether the weaver is in correct costume I can not say, but the loom and its fittings are quite recognizable and like the loom of to-day, except for their slightness.

Figure 35 (pl. 9) is from a very old Chinese drawing. It is one of a set of pictures representing the operations of sericulture. The first edition of the book from which it is taken is said to be of the twelfth century A. D.

It is the representation of a very perfect hand loom for silk weaving. The weaver is shown sitting on the edge of a square hole in the ground, in which a set of treadles are seen. The framework of the loom is very carefully and solidly constructed. The front or cloth beam is shown with the reed hanging freely between it and the heddles. The back, or warp beam, is out of the picture, and the warp

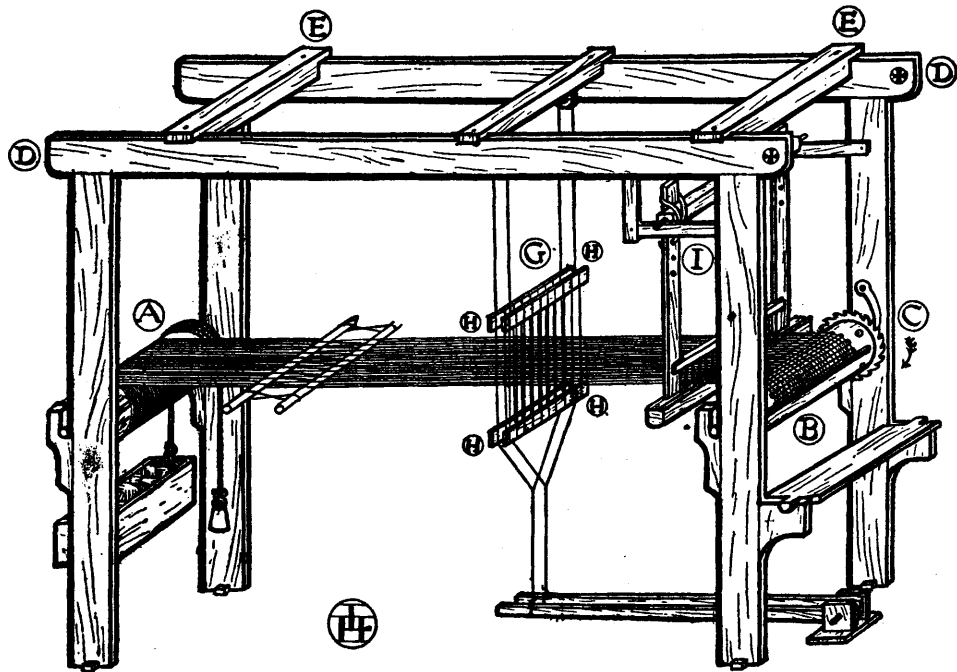

FIG. 33.—Typical English hand loom.

slants toward it after passing through the reed and heddles. The heddles themselves are very carefully fitted up and are worked by means of the treadles in the pit, which are connected by cords to levers. These levers may be seen at the top of the picture.

The weaver, sitting in front of the loom, has just, by a blow of the reed, beaten up the weft and is preparing to open the next shed and throw the shuttle which he holds ready in his right hand.

It will at once be noticed that the Chinese loom (fig. 35, pl. 9) has several heddles, instead of only two shown in the English loom (fig. 33). In fact, there are two sets of heddles working together, one set having 10 and the other 5 heddles.

The loom having two sets of heddles shows that some kind of pattern is being woven. As, however, at present I am speaking of the loom for plain or satin weaving, the second set of heddles need not concern us.

When the warp threads are very coarse and few in number, two heddles are sufficient for threading the warp, but when fine silk fabrics are to be woven, having three or four hundred threads to an inch, it is necessary to have several pairs of heddles in order to prevent the leashes, through which the silk is threaded, from being too crowded. In this Chinese loom the front harness, as a collection of heddles is called, consists of 10 separate heddles. In all looms the threads of the warp are passed through the eyes in the leashes of the heddles in regular order.

The first thread is passed through the first leash of the first heddle, the second thread through the first leash of the second heddle, then through the first of the third, and so on until all are filled.

[The lecturer here drew a diagram on the blackboard illustrating the method of entering a warp in the harness.]

To manage this set of 10, or any even number of heddles, only 2 treadles are necessary for plain or tabby weaving. The heddles are

first joined together in pairs at the top, each pair having its two separate pulleys, as in the typical English loom. (Fig. 33.) The bottom laths of the first, third, fifth, seventh, and ninth heddles are then all connected with one treadle, and those of the second, fourth, sixth, eighth, and tenth heddles are joined to the other treadle.

Now, it is manifest that if the first treadle be depressed half the warp, consisting of the first and all the odd-numbered threads, will be drawn down and the second and all the even-numbered threads will be drawn up. This will make the same opening for the weft as if there were only 2 instead of 10 heddles.

In order to make this quite clear, the plan and tie-up of the pattern, as it is called, is given at figure 36.

This arrangement being at first made for plain tabby weaving of a close warp of fine threads, it would soon be discovered that by increasing the number of treadles and tying them to the heddles in different ways the interlacements of warp and weft might be varied

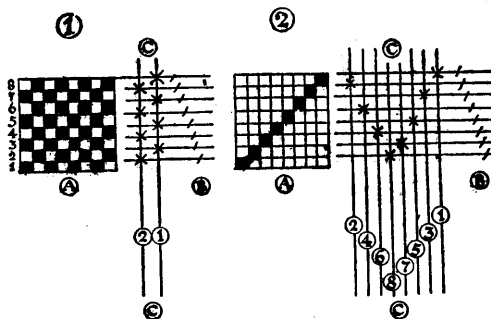

FIG. 36.—Plans of tie-up.

to an astonishing extent and result in the production of an infinite variety of small patterns.

Figure 37 gives, for example, four designs, which can be made on a loom fitted with four heddles and four treadles. If the threads of warp and weft are coarse enough, and the former white and the latter black, the designs would show as distinctly when woven as they do drawn out in the diagram.

There is not time, nor is it indeed necessary for our present purpose, to describe the way in which these designs are formed. All that is required is to note their possibility and to show how this possibility affected the development of the loom itself.

A further examination of this ancient Chinese loom will show that not only are there more than two treadles in use, but instead of the heddles being tied together in pairs, as for plain weaving, each heddle is connected with one of

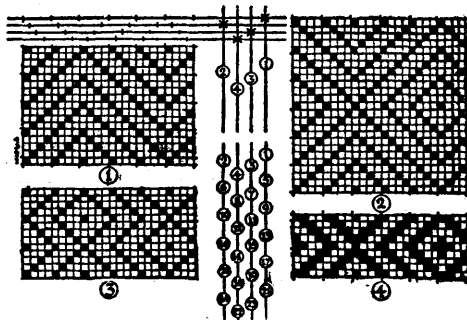

FIG. 37.—Simple designs.

a set of levers which in their turn are joined by a cord to the treadles.

Figure 38 represents, without other details of the loom, two typical shedding motions, as any arrangement for opening the shed for the weft is called. In both these motions, as in the Chinese loom, the arrangement

is one of heddles, levers, and treadles connected together by cords. Below each diagram a longitudinal section of a loom at work is shown.

It is interesting to note that these ancient shedding motions are still in use. Silk fabrics made on hand looms fitted with these motions can not be equaled by webs woven on any machine loom yet invented.

Figure 39 (pl. 9) which I drew from a Bethnal Green workshop, as it now is, shows a silk loom with precisely the same fitting up as the Chinese artist has drawn.

To return to the shedding motions (fig. 38); in the right-hand figure the heddles A A have lead weights, B B, on their lower shafts. If, therefore, any of the four heddles be raised, as soon as they are released the weights will bring them down to their normal position. At the top of the loom, letter C, four short strong levers are fixed on an iron rod, which passes through a hole in their centers. From one end of each of these levers a heddle is suspended; and from the other end a cord hangs and connects each short lever with a long

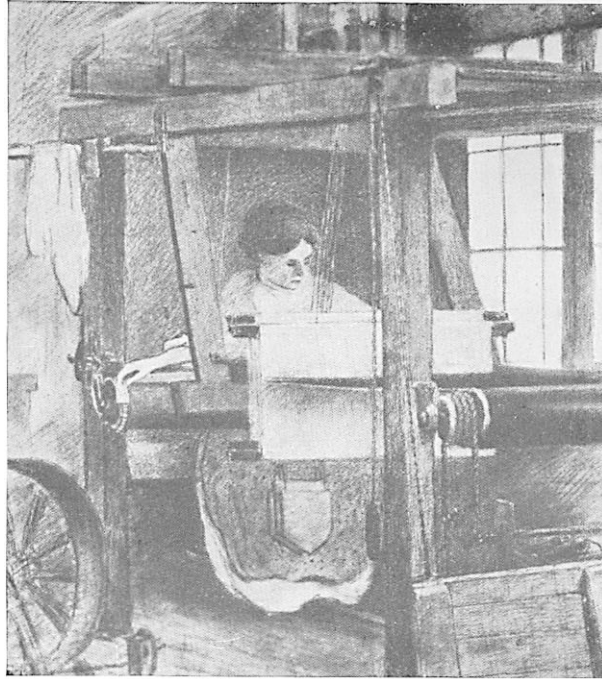

FIG. 32.—BETHNAL GREEN SILK WEAVER.  
(From a drawing by the author.)

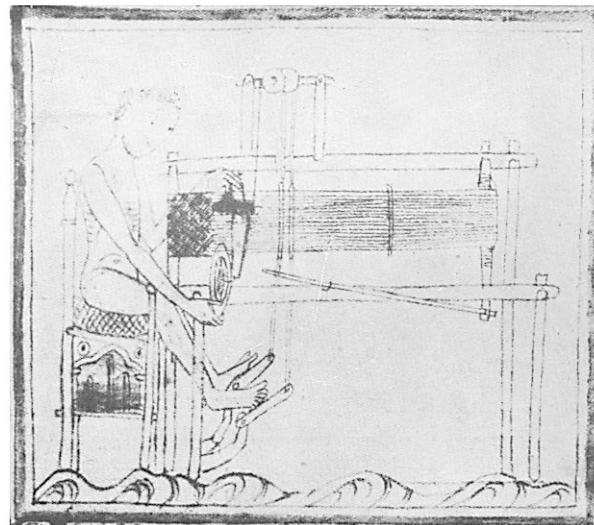

FIG. 34.—ENGLISH SILK WEAVER, FOURTEENTH CENTURY.  
(From an old manuscript.)



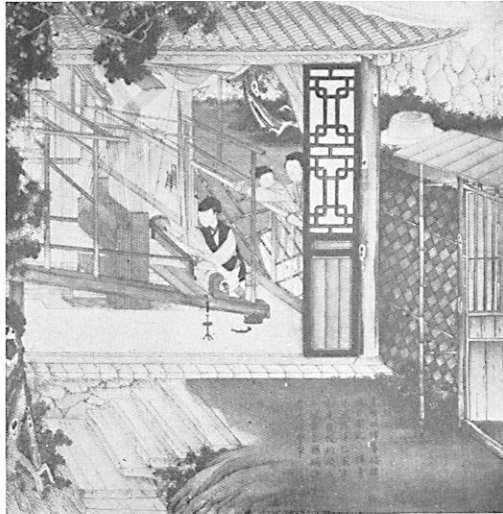

FIG. 35.—CHINESE SILK-WEAVER'S LOOM.  
(Ancient Chinese drawing.)

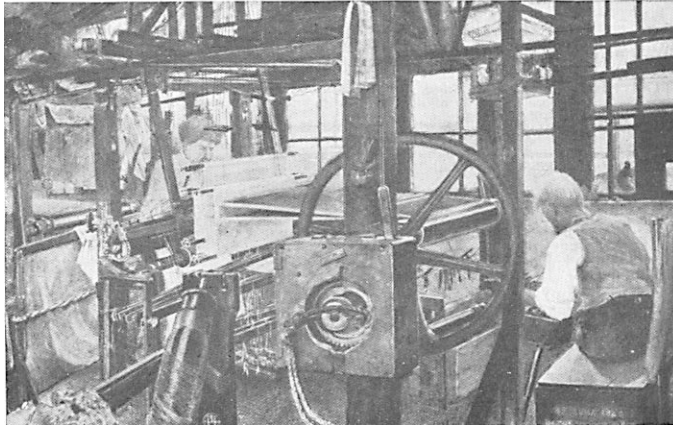

FIG. 39.—BETHNAL GREEN WEAVING SHOP, 1911.  
(From a drawing by the author.)

one, D D, which hangs across the loom below the heddles and above the treadles, which are lettered E.

It will now be seen that if any one or more of the long levers be tied to any one of the treadles, the weaver sitting in the loom has only to select and press a treadle in order to raise any arranged combination of warp threads for the weft to pass under as it is carried by the shuttle through the opened shed.

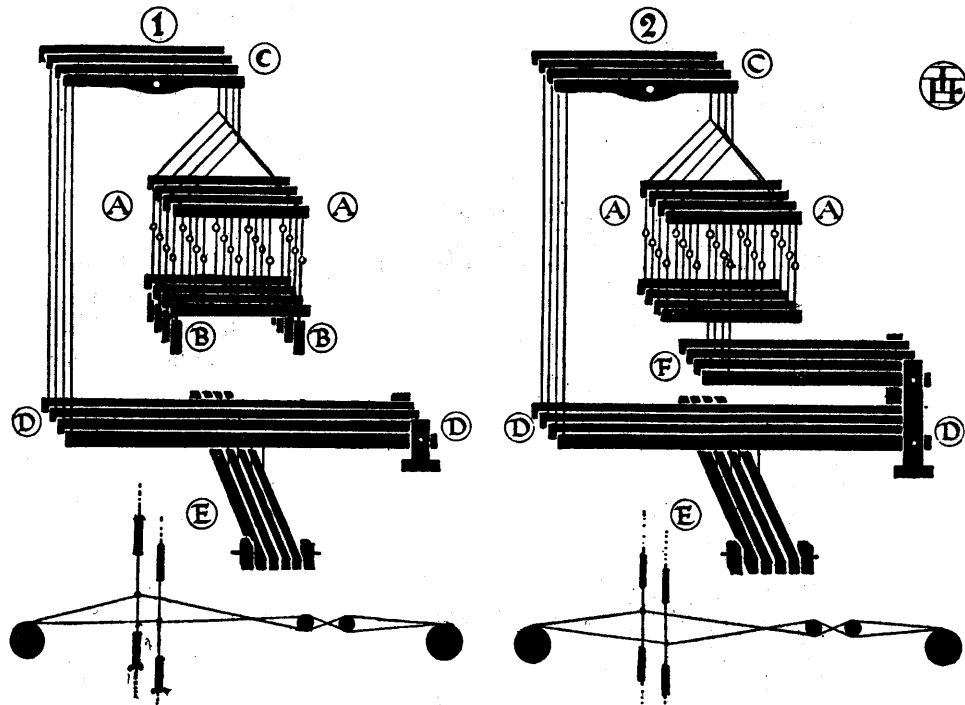

FIG. 33.—Shedding motions.

The character of the shed made by this motion is shown above. The horizontal line is the normal position of the warp. The opening is made by raising certain selected threads.

An examination of the section below No. 2 will show that in it not only are certain threads of the warp raised, but all others are lowered, and the horizontal line of warp has disappeared. This is effected by adding to the motion another set of short levers, marked "F," between the long ones and the heddles, and connecting the lower shafts of the heddles with them after removing the weights. If, now, for example, the first thread be required to rise and the second, third, and fourth threads to sink, the first treadle will be tied to the first long lever, and also to the second, third, and fourth short levers. The result of this will be that when the treadle is depressed the first

heddle will be raised and the second, third, and fourth heddles will sink, thus making the required shed.

These are typical shedding motions. All other motions are based on one kind or the other of these types, each kind having its advantages for certain classes of weaving.

I have already pointed out that such patterns as those of figure 37, woven of single threads, require the thread itself to be coarse in size in order to show as designs. But such designs, woven in fine silk, although indistinguishable as ornament, have a marked effect on the appearance of the texture of the web.

The Chinese early discovered this fact, and it was for their various beautiful and rich textures that the woven silks of China were so much prized in classic times.

Figure 40 represents the back and front surfaces of a square of silk textile, which might

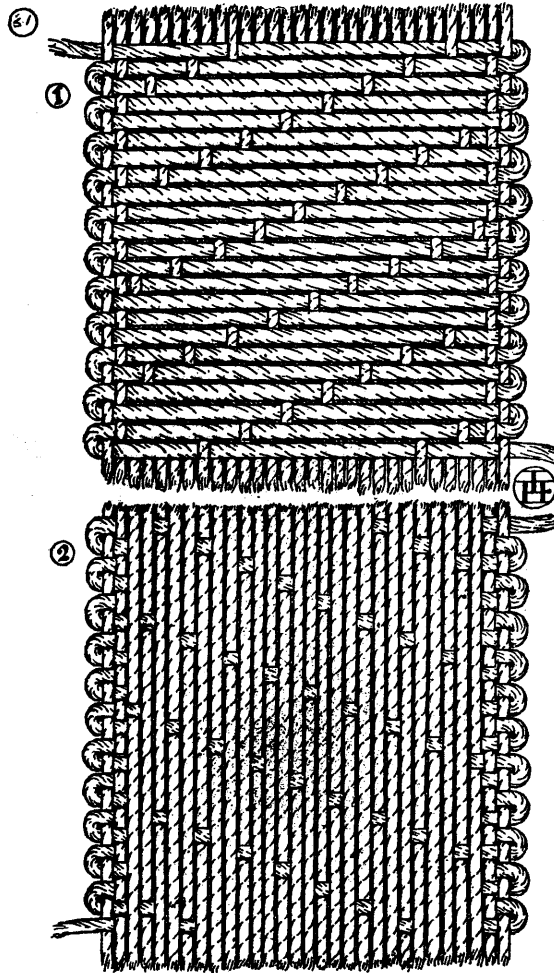

FIG. 40.—Satin cloth (much enlarged).

have been woven in ancient China on a loom fitted up as I have described. It would require 16 heddles and 16 treadles to weave it, and the threads are so fine and lie so closely that the whole piece shown would be only the one-thousandth part of a square inch in size.

Looking at the lower square, which is the front of the material, it will be seen that the surface is nearly all warp, and that the intersections of the weft only occur at intervals of 16 spaces each way. In

cloth of this pattern the intersections of the weft are invisible; therefore its whole surface has the rich texture and glossy appearance known as satin. In the same proportion as the front of the satin web is nearly all warp, the back, of course, displays the weft. In pattern weaving these effects are called, respectively, warp satins and weft satins.

Satins may be made on different numbers of heddles, from 5 up to 24. Figure 41 shows several of them drafted on designers' ruled paper.

The next step in the evolution of the loom was to adapt it for distinct pattern weaving. This was effected by adding a second set of heddles to the harness, making it what is called a compound harness.

This compound mounting is shown in the Chinese drawing. The front set of 10 heddles is for making the groundwork of the fabric, and the back set of five is for raising the figure, as the design is usually called in weaving.

Here is a very simple figure (fig. 42), which will well illustrate the method of double harness pattern weaving. It is of a kind, too, of which the Chinese are very fond, having spots of ornamental shape powdered over a plain ground. Moreover, it could be woven on a loom fitted up exactly as in the Chinese picture.

The ground of this design is a plain tabby silk. I have already shown how this can be woven in a harness of 10 heddles by means of 2 treadles. Five other treadles would, however, have to be added in order to work the figure harness, one for each heddle.

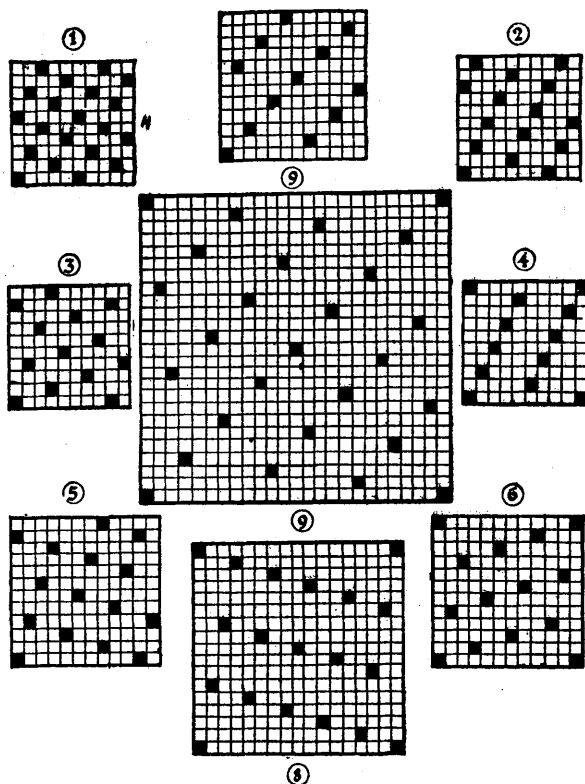

FIG. 41.—Satin ties.

For double harness weaving, too, the leashes of the heddles of the front harness have an important peculiarity which must be described; for, though simple, it plays a most essential part in all pattern weaving with compound harness.

In this class of weaving each warp thread passes first through the eyes of the figure harness and then through those of the front harness, which makes the ground. Now, if both harnesses are alike fitted with leashes having the ordinary short eyes, only the front one can affect the shed. This is because any threads raised by the back harness are prevented from effectually rising in the reed by the leashes of the front harness.

If, however, the front harness eyes are made long enough to allow the warp threads to be lifted, the back harness will be free to affect the shed at the same time as the front harness, or to affect it alternately as may be required. The diagram (fig. 43) will make this clear.

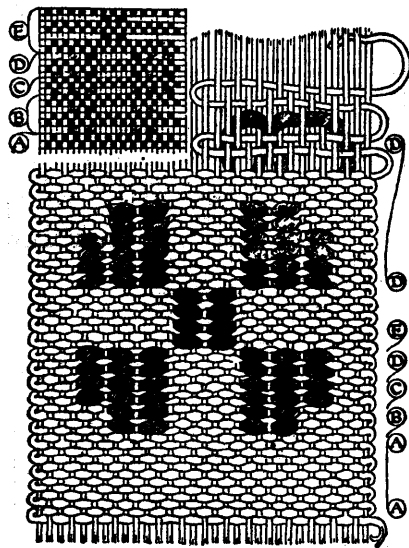

FIG. 42.—Double harness weaving.

If, now, we turn again to figure 42, the part played by the figure harness can readily be explained. The points to notice are: (1) Two extra wefts are required for weaving in the design which has two separate colors of its own; (2) the figure is formed by allowing the colored weft in certain places to pass over two threads of the warp instead of one; (3) the necessity for five heddles in the figure harness is to be gathered from the fact that five different combinations of pairs of rising threads are required to complete the design; (4) as the figure throughout is made by two threads rising together, two threads together may be entered in each eye of the figure harness.

If this explanation is clear, it is only necessary to add that in silk weaving not only 2, but sometimes as many as 20, warp threads are entered in each leash eye of the figure harness. Therefore, it is evident that the possible scale of ornamentation and scope for the designer are immensely increased. For instance, this figure woven on two threads, as explained, on a fine silk warp of 400 threads to an inch, would only occupy the sixteenth of an inch in width and height, but if 20 threads were entered together in each leash eye of the figure harness the size of the ornament would be increased 10 diameters and would occupy nearly a square inch of surface.

There is, therefore, represented in this old Chinese drawing (fig. 35, pl. 9) a very perfect loom for weaving small designs of simple construction. The limit of size and elaboration of the pattern in this kind of loom is, however, reached when the number of figure treadles and heddles becomes too great for practical use. There is no evidence of the Chinese having endeavored to weave with an elaborate system of heddles and treadles such as were ingeniously devised in England in the eighteenth century, but which, being very difficult to fit up and manage, were soon superseded.

Figure 44 (pl. 10), taken from the same Chinese book as the foregoing Chinese drawing, shows, in a compound loom, a figure harness of entirely different construction, which is evidently made on the same principles as the perfected European drawloom of the eighteenth century, on which were woven the most sumptuous

and intricate webs which the weaver's art has ever produced. In this representation of a pattern weaving loom, instead of the small figure harness of five heddles, a large one of quite different build is shown. Over this harness an assistant weaver, perched aloft at the back of the loom, is presiding. He is, in fact, drawing up, according to an arranged plan, certain groups of threads required for the formation of a pattern. The all-important part of this picture is the portion of the loom over which the assistant weaver is presiding.

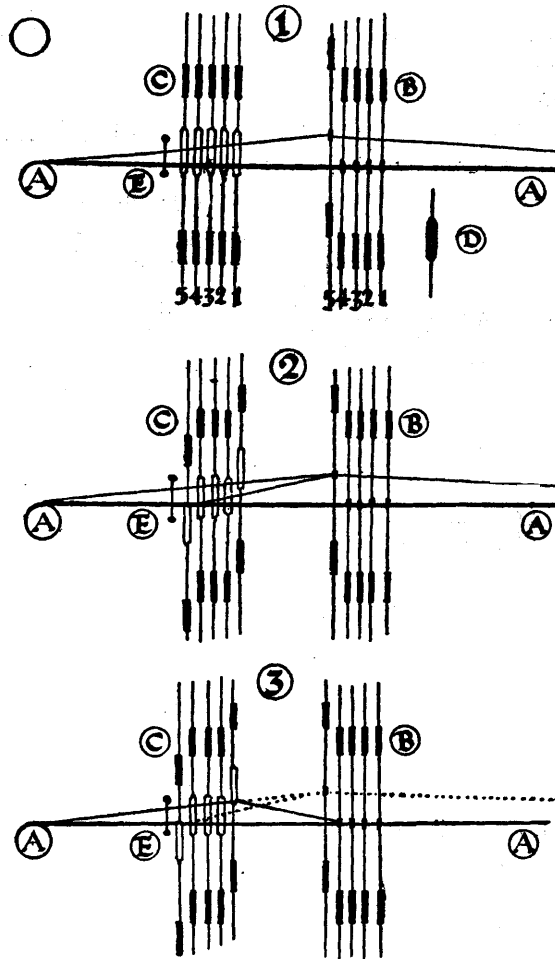

FIG. 43.—Double harness shed sections.

Taken by itself, it is a complete loom harness of remarkable capacity. In fact, for automatic pattern weaving, a loom fitted with this contrivance for raising the warp threads only is as complete in its way as the perfected primitive loom is for tapestry weaving, as I pointed out in the last lecture.

Although the Chinese picture represents what is unmistakably a draw-loom apparatus, it is not clear enough in detail to describe the machine from. I must, therefore, have recourse to a diagram. (Fig. 45.)

Here, at No. 1, I have represented in diagrammatic form the simple draw loom and at No. 2 a design on ruled paper suited to its capacity, which is purposely kept very limited for the sake of clearness.

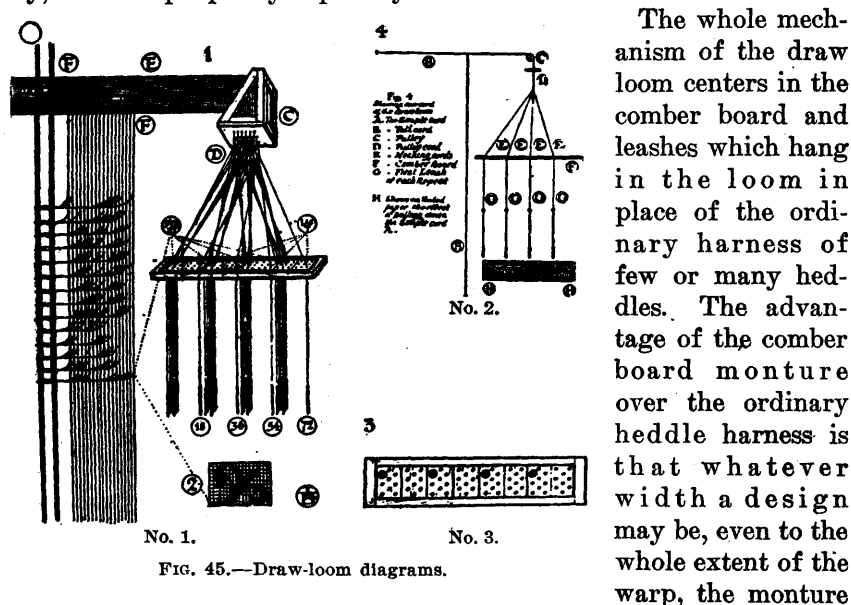

FIG. 45.—Draw-loom diagrams.

takes up no more longitudinal space in the loom than a harness of a few heddles.

The comber board, No. 3, is simply a board pierced with a number of holes equal to the number of threads of the warp which it is to govern.

In each of these holes a separate leash is hung. Each leash has a long, thin lead weight at its bottom end; and in its center, instead of a string loop, a glass eye called a mail, through which a warp thread is entered.

The comber board in the diagram is only pierced with 72 holes; consequently it is only for a warp of 72 threads. If it were for 72,000 threads of fine silk, it would not take appreciably more space in the loom.

The whole mechanism of the draw loom centers in the comber board and leashes which hang in the loom in place of the ordinary harness of few or many heddles. The advantage of the comber board monture over the ordinary heddle harness is that whatever width a design may be, even to the whole extent of the warp, the monture

The drafted design at No. 2 is made on 18 lateral squares, so that it would repeat four times in the width of the web to be woven.

The word "comber" board is derived from an older word, "camber," which used to signify the repeats of a design as regards width. The board was called a camber board because the holes pierced in it were accurately apportioned to the number of threads in each pattern repeat, and the width of the total number of holes was the same as the width of the warp.

In this comber board (fig. 45) there are holes for four repeats of 18 leashes, but only six leashes of each repeat are shown in position, as more would confuse the drawing.

The bottom board of the triangular box C is pierced with 18 holes, the same number as that of the threads in each repeat of the design.

Let us suppose the comber board to be filled with leashes, one suspended in each hole; also that 18 cords are hanging through the holes in the triangular box at D.

The mounture builder now connects, with fine cord, the first, nineteenth, thirty-seventh, and fifty-fifth leashes, which are the first in every repeat with the first hanging cord at D.

He next takes the second leash in each repeat, and connects it in like manner with the second cord at D.

He proceeds thus in regular order to connect leashes and top cords until he reaches the last of the repeats, leashes 18, 36, 54, and 72.

When this work is done it is apparent that if any one cord at D is drawn up into the triangular box the corresponding leashes in every repeat will be drawn up through the comber board to a corresponding height.

Moreover, if 72 threads of warp are entered in the leash eyes, the selected leashes as they rise will raise the threads necessary for the formation of the pattern shed.

This is the essential portion of the draw loom, and so far is it from being obsolete that all the pattern-weaving looms of to-day, whether worked by hand or power, are identical with it. Thus the immense textile industry of modern times is indebted to and linked with the invention and industry of ancient China.

Vast numbers of different methods of drawing up the cords of the loom were no doubt practiced in the East. Most frequently, as in the Chinese picture (fig. 44, pl. 10), the weaver's assistant who did this work sat above the loom drawing the cords line by line according to a written or painted draft.

There is no evidence to show what form this part of the loom had assumed when the art of silk pattern weaving was introduced into Sicily in the twelfth century. The rapid development of silk weaving in Sicily and Italy, which we know took place makes it more than probable that the convenient method of drawing the cords from



the side of the loom, as shown in this diagram (fig. 45), was invented soon after the art was introduced. However, when introduced or by whom invented, it is certain that it was on looms mounted and fitted up in this manner that the masterpieces of the weaver's art, made in Europe from the thirteenth to the eighteenth centuries, were produced.

I resume the explanation of the diagram of the draw loom (fig. 45) at the point D, where the 18 cords are seen to enter the triangular box C. This box is fitted up with pulleys, 18 in number. Each cord passes over a pulley and is seen again at E. The collection of 18 cords, called the tail of the monture, is then securely fastened to the wall of the workshop, or some convenient strong post.

Between F and F another series of 18 cords, called the simple, is tied to the tail series and fastened to the ground.

A simplified diagram, showing one cord in all its parts, is given in No. 4.

Now, it will at once be seen that if the cord A be pulled down by an assistant standing at the side of the loom, the eyes of the leashes G, through which the warp threads pass, will be pulled up.

It is necessary, then, in the simple, to have as many cords as there are threads or groups of threads in each repeat of the comber board. And it is possible to weave on the loom any design, of whatever length, that can be drawn on the number of threads arranged for in each repeat.

If we turn to the design No. 2 we shall see that it is drawn on 18 squares, and if we compare the design with the loops tied from the large guiding cords to the separate cords of the simple, we shall see that they agree. The black squares in the design represent a tie. Take the first line, beginning at the left-hand side. Here are six black squares. If we follow the dotted line to the first cord of the simple, a group of six ties will be found. Then passing over six cords, a group of four ties are found which correspond with the four black squares in the third division of the sketch.

By means of these loops the drawboy, as he was called, selected the cords for pulling down, and, having gathered them together on the prong of a large fork, to which a lever was attached, he pulled the lever and drew the leashes up, thus opening the shed for the weaver's shuttle.

The design had to be tied up on the simple cords line by line before weaving could commence; but when this was once done the drawboy had only to pull the cords, in regular sequence, in order to repeat the design continuously in the length of the web.

On this mounting of the loom entered with single threads of warp any possible interlacements of warp and weft can be worked out. It may well be called, therefore, the most perfect loom. Its only limi-

tation is in the size of the design. It would require a simple of 400 cords to tie up a design one inch wide for a silk web 400 threads to an inch.

This difficulty was surmounted by adopting the compound harness arrangement I have already described. It is shown in the Chinese drawing of the pattern-weaving loom (fig. 44, pl. 10).

If threads entered singly in the front harness are lifted in tens by each leash of the figure harness, the design will be woven 10 inches wide instead of 1 inch; the simple and tie-up being no more extensive or complicated.

More elaborate interlacements of warp and weft were arranged for by dividing the comber board into two or even three parts, each governed by a separate set of simple cords, as well as by adding more warps and rollers to the loom, and additional harnesses of heddles for binders and stripes of satin, tabby, or tobine effects. In fact, there seems to be no limit to the different combinations the skillful designer may invent and provide for in this most perfect and adaptable of all craftsman's tools, the compound draw loom.

In my third lecture I shall describe the Jacquard machine and some other important weaving inventions of the eighteenth century, the evolution of the power-driven loom, describe a new circular loom, and indicate some possible developments of the weaving machines of the future.

### III. THE JACQUARD MACHINE; POWER-DRIVEN LOOM.

#### INTRODUCTION.

In the two previous lectures my chief aim has been to point out the traditional continuity of the art of weaving and to show that all real advances in it have been made by bringing new ideas to bear on old principles. This method of advance is common not only to the textile but to all the arts of life. Man, at his best, is not a creator, but an improver, and all attempts to break with tradition and to produce something quite original always must end in more or less grotesque failure.

I have tried to bring this truth out as regards the hand loom and spindle, and in the present lecture I shall chiefly direct your attention to the same fact, as exemplified in the development of the mechanism of the power loom during the last century.

#### THE MODERN LOOM FOR PLAIN AND ORNAMENTAL WEAVING AND ITS FUTURE DEVELOPMENT.

In the early part of the eighteenth century, weaving, as a handicraft, reached in Europe its point of highest perfection. France, England, and Italy were the chief countries in which it was practiced.

At that time, in England particularly, the condition of the textile craftsman, of whatever grade, seems to have been better than at any other period of which we have record.

The weaver of the eighteenth century was a prosperous and respectable tradesman, whether working in the secluded country village, in the suburbs of the great towns of the north and east, or near the metropolis in the pleasant district of Spitalfields, notable as the silk-weaving quarter of London.

This happy condition of the weaver in the eighteenth century declined to one of misery in the nineteenth. The economic causes of this change are not far to seek, but form not part of my subject. I only refer to this period of prosperity, as it marks an important stage and change of direction in the development of the loom.

Hitherto the motive of inventors was to increase the scope and perfection of the loom, as a pattern-weaving tool. The perfection attained and the care bestowed on loom construction are shown in the beautiful illustrations of Diderot's Dictionary and other technical works of the period.

During the latter portion of the eighteenth century, and since, the chief purpose of invention has been, not excellence of work and extended capacity of the loom, but economy of time and cheapening of production.

The interesting business of weaving, from the tying up of the design to the picking and finishing of the woven cloth, which the weaver originally did himself, is now divided up amongst half a dozen "hands," who only do one particular portion of the work, and thus monotonously perform their daily task.

Not only is the weaver's work to a certain extent degraded, but the change from wood to iron for loom construction and the use of steam as a motive power, as well as the subdivision of labor, have necessitated the grouping of looms in large factories, with all their inconveniences and attendant evils.

This revolution of industry occupied more than a century and a half and was effected in some branches of the trade sooner than in others. The process is, in fact, in the best branches of silk weaving, still going on.

The first indication of the coming change in the broad-weaving trade was given as early as 1687, when Joseph Mason patented a machine which he described as "an engine by the help of which a weaver may performe the whole work of weaving such stufte as the greate weaving trade of Norwich doth now depend on, without the help of a draught-boy, which engine hath been tryed and found out to be of greate use to the said weaving trade."

It is necessary to the understanding of the mechanism of the important machine which superseded it, which I shall presently fully

describe, to have a general idea of this drawboy machine. In order to give this idea, however, I must first describe the work of the human drawboy. For the purpose we shall need the diagram of the draw loom (fig. 44, pl. 10).

[Here the lecturer again briefly repeated his explanation of the various parts of the draw loom.]

In a rich silk loom there were often as many as two or three thousand lead weights, called lingoos, hanging three to each leash of the monture. These weigh altogether a couple of hundredweight. On an average half of them had to be drawn up at every line of the design. Moreover, their dead weight would be so increased by the friction of the multitude of cords and pulleys that the boy would have to raise and hold for several seconds a weight equal to a hundredweight and a half. This would, of course, be impossible but for some mechanical help. The implement devised for the boy's assistance was called the "drawboy's fork."

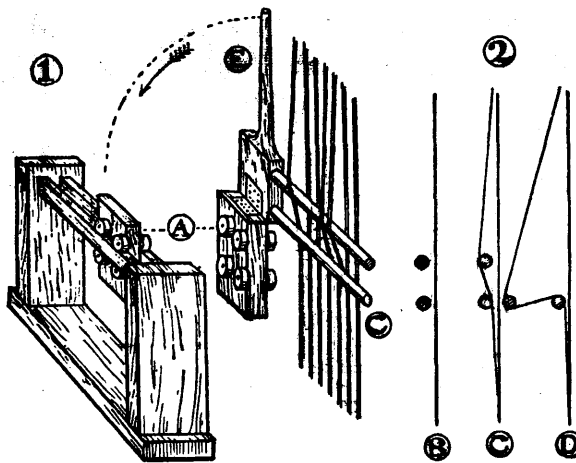

FIG. 46.—Drawboy's fork.

This is shown at figure 46. The vertical lines in this diagram represent the cords of the simple.

To the left is a solid stand having two broad uprights joined together at the top by two parallel bars. A is a block of hard wood, which fits between the bars, and is held in position by four pairs of small wheels. These not only support it but allow it to run freely from end to end of the stand.

This block, with the fork and lever attached, is shown separately at E. The fork and lever are hinged to the block at its top and can be moved from the vertical to a horizontal position. When about to be used the block is moved till the points of the fork are just beyond the backmost cord of the simple, the lever being in an upright position.

By means of the loops tied to the simple, as shown at figure 46, the required cords are drawn forward and the upper prong of the fork inserted in the opening thus made. Then, grasping the lever, the

boy draws it down and holds it. The result of this is that the selected lingoes and leashes are drawn and held up.

At No. 2 three sections of the simple are shown lettered B, C, and D. At B the cords are at rest. At C some cords have been selected and the fork inserted. At D the lever has been pulled over and the cords drawn over with it.

Figure 47 shows the mechanical drawboy, a machine invented in the seventeenth century and improved during the eighteenth. It was attached to the pulley cords of the loom, on which, when the machine was used, the tie-up of the design was made, instead of on the simple.

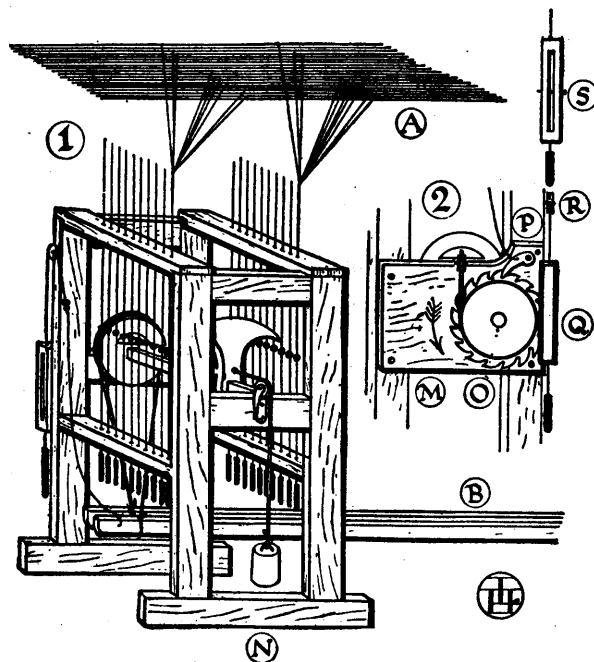

FIG. 47.—The mechanical drawboy.

The active part of this machine is the pecker, which by means of two treadles and some little mechanical arrangements had two movements: (1) It rocked from side to side; (2) it moved, as it rocked, along the machine from one end to the other.

Through holes in the side cross-pieces of the frame strong cords terminating in heavy weights were hung. To the tops of these cords the loops of each row of tie-

ups were attached in regular succession. Only two rows are shown connected in the diagram to prevent confusion of lines.

The pecker had a deep notch cut in its points and was of such a size that as it rocked the cord toward which it inclined caught in the notch. At the center of the cord a large bead was fixed. When the rocking pecker came in contact with this bead it pushed it and its cord down and held it until the second treadle moved the pecker in the opposite direction.

As the pecker traveled along the shaft each cord was drawn down in its turn, thus opening the shed, line by line, for the working out of the pattern.

The number of lines in the length of a design, of course, had to correspond with the number of cords in the machine. The drawboy machine was not to any great extent used for the purpose for which it was intended, viz, to supersede the drawboy of the compound figure weaving loom. I suspect the boy was useful in many ways about the loom, and, moreover, his wages would be no great matter. But late in the eighteenth century, and well into the nineteenth, the machine received a good deal of attention and was improved and adapted for use with the treadle hand loom. It enabled the weaver to work any complicated system of heddles, for small-pattern fancy weaving, with only 2 treadles instead of 20 or more.

Figure 48 is from Porter's *Treatise on Silk* (1831). It represents an improved drawboy machine for which the Society of Arts awarded a prize in 1807. Further improvements were made later, but it was finally superseded by the famous machine which was perfected by Joseph Marie Jacquard, and known in England as the "Jackard" machine.

There can be no doubt that it is to Jacquard that the credit of rendering this machine thoroughly practical is due, although it has been proved that the fundamental idea of it, which consists in substituting for the weaver's tie-up a band of perforated paper was first applied to the draw loom in 1725, while in 1728 a chain of cards was substituted for the paper and a perforated cylinder also added.

These early contrivances were placed by the side of the loom and worked by an assistant. In 1745 Vaucanson placed the apparatus at the top of the loom and made the cylinder rotate automatically. But it was reserved for Jacquard to carry the machine to such perfection that, although many slight improvements have since been made in it, it remains to-day practically the same as he introduced it in 1801, notwithstanding the astonishing development of textile machinery during the nineteenth century and the universal adoption of the machine both for hand and power weaving.

Although the invention was introduced to the French public in 1801, it was not till 1820 that a few Jacquard machines were smuggled

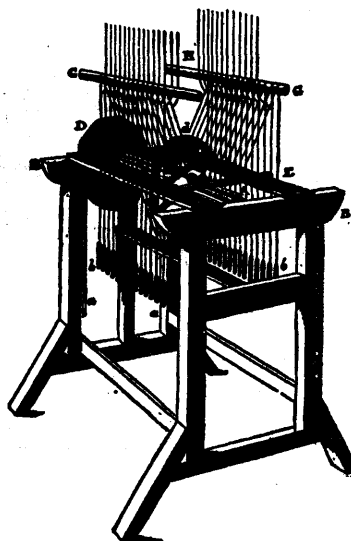

FIG. 48.—The mechanical drawboy.  
(Early nineteenth century.)

into England and secretly set up. In spite of much opposition they soon came into general use, first and particularly for hand looms and silk weaving, but afterwards for power looms, all kinds of fancy and ornamental webs being since their adoption woven by their means.

May I here repeat and emphasize that the invention of the Jacquard machine did not alter in the least the draw-loom method of pattern weaving? It only took the place of the drawboy and the pulley box, and substituted the endless band of perforated cards for the weaver's tie-up.

The designs, too, drafted on ruled paper, would be worked out in precisely the same manner, whether for tying up on the cords of

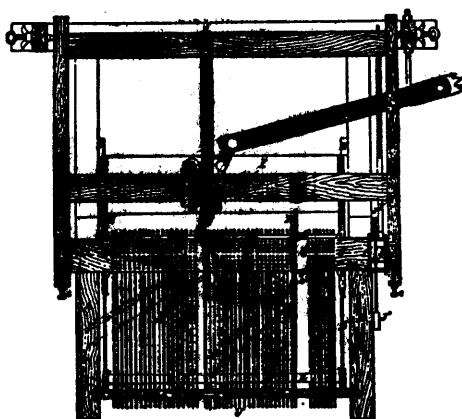

FIG. 49.—Jacquard machine. (Front elevation.)

a simple or for punching in a set of Jacquard cards. Each card, in fact, takes the place of one row of loops of the tie-up.

The term Jacquard weaving, then, which one so often hears used, is a misnomer. It should be draw-loom weaving with a Jacquard machine, the machine being only an ingenious substitute for a less compact and manageable adjunct of the draw loom, an adjunct, moreover, which, as we have

seen, has continually varied from the time of the invention of this form of loom. After the draw loom itself I should class the Jacquard machine as the most important invention in textile mechanism. It therefore claims a careful description.

Figure 49 is a drawing of the front elevation of a 400 Jacquard machine. The number 400 refers to the number of needles and hooks with which the machine is fitted up. These needles and hooks answer to the number of the simple cords of the draw loom. A design is still technically spoken of as being drafted for so many cords.

The position of the machine in the loom is at the top, where it is fixed on a solid frame just over the comber board, usually with its end to the front of the loom, so that the elevation shown in the figure is parallel with the side of the loom frame.

The machine frame is oblong in shape. It is made of hardwood for hand looms and of iron for power looms. But in either case it needs to be of great strength. To the principal frame a smaller one is hinged at the top, so that it can be raised like a flap.

In this drawing 50 wire hooks are seen standing upright on the bottom board of the machine. The bottom board is perforated with as many holes as there are hooks in the machine, in this case 400. The hooks represented are only one rank out of eight, which the machine contains. Each hole in the bottom board has a dent or groove cut across the top, in which the bent end of the wire hook rests. This keeps the hook firmly in position, especially when the necking cords of the harness are brought up through the holes and looped on to the wire.

Figure 50 gives two sections of the machine, one showing it at rest and the other showing it in action. In both sections 8 hooks are drawn, 1 from each rank of 50.

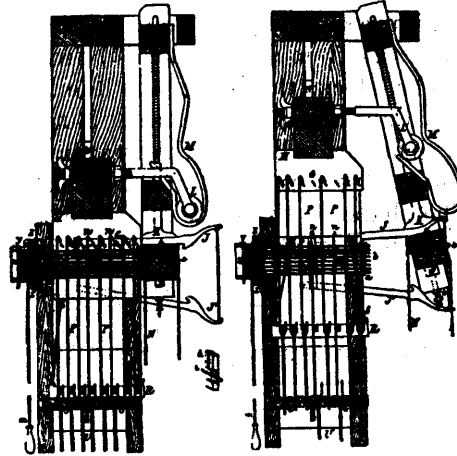

FIG. 50.—Sections of Jacquard machine.

The hooks have the necking cords attached at the lower ends, and just below the small hook at the top may be seen a set of eight wires crossing them at right angles. Each of these wires, called needles, is bent into a loop or eye, where it crosses one of the hooks, and it is because the hook is passed through this eye that it is retained in an upright position. Figure 51 will show this arrangement quite clearly.

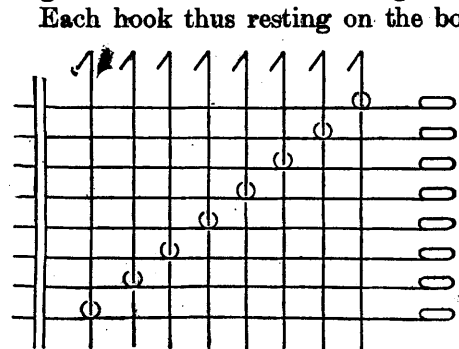

FIG. 51.—Diagram of hooks and needles in a Jacquard machine.

Each hook thus resting on the bottom board, and held down by the weight of the leashes of the harness, though supported at the top by the eye of the needle, through which it passes, is still free to rise and raise with it the leash or leashes to which it is attached.

Leaving the hooks thus standing, let us consider the arrangement for lifting them.

Above the hooks the section of a solid block of heavy wood or iron is shown. This block runs from end to end of the machine, and has projections at its ends which fit into the narrow spaces between the two pairs of uprights of the machine frame in such a manner that the block can be caused to slide up and down steadily but freely.



Now, let us look at the block in the drawing of the front elevation (fig. 49) and then at a drawing showing the block in detail, separately.

The lever for raising the block, being extended to a convenient length, is connected by a rope to a treadle worked by the weaver's foot in the hand loom, or by any ordinary mechanical arrangement in the power loom.

Figure 52 gives us details of the block (1) as seen in front elevation; (2) from above; and (3) from the end.

The block, the lever, and the arrangements for sliding up and down are already explained. But hanging from the block is a kind of gridiron, called by the weaver a "griffe," which requires careful notice. Near each end of the block a flat plate of iron is firmly fixed. The shape of the plate is shown at No. 3, and between the plates, eight bars of hoop iron are fitted, as at No. 2. These bars are placed

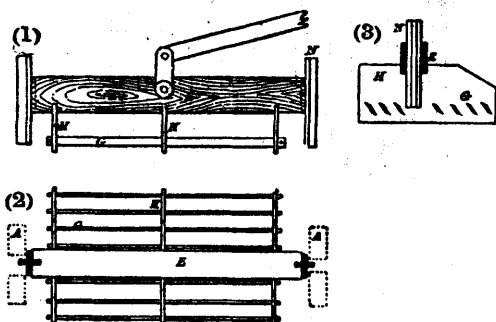

FIG. 52.—Details of the block of a Jacquard machine.

diagonally (see No. 3) and their top edges are sharpened so as to fit under the carefully made small hooks at the top ends of the upright wires as they stand in their several rows.

The first section of figure 50 shows the block at its lowest position, with the hooks caught on the

bars of the griffe. Should the block now be raised the whole of the 400 hooks will be drawn up and the whole warp will rise with them. When released, of course, all will fall together, pulled down by the lead weights. Again, if the projecting ends of the needles are pushed inward, the needle eyes will deflect the hooks and remove them from the griffe, which will then, if the block be raised, rise by itself, leaving the hooks, leashes, and warp all down, as in section 2.

In section 2 the points of the needles are seen to pass through and project beyond the surface of an accurately perforated board fixed to the front of the machine frame opposite the needles. Hung in the frame, hinged to the top of the machine, is a four-sided revolving bar, or cylinder, each side being perforated so as to match exactly the perforations of the needle board.

If the flap, with the cylinder in it, be pressed against the board, and the block raised, nothing different will happen, because the points of the needles will have been free to enter the holes in the cylinder. If, however, a card covering all the holes be fixed to one side of the cylinder and the cylinder then be brought close up, presenting each side in regular succession, every time the card comes in contact with

the needle points the needles will be pressed inward, push the hooks off the bars of the griffe, and the block will rise without them.

It follows, then, that if we interpose between the needle points and the side of the cylinder, as it presses the needle board, a card perforated according to an arranged design, wherever a hole is covered by the card a needle will be pressed in, and consequently a hook will be pushed off the griffe bar and left down as the block rises.

Each card, therefore, affects, in one way or another, every hook in the machine with its necking cords and leashes; and these, of course, determine the rising or remaining down of every thread of the warp from edge to edge of the web.

At the back of the machine a shallow box is fitted, containing 400 small spiral springs, one for each needle. When therefore, any needle is pressed inward by the card on the cylinder, its opposite end is forced into the spring box, but as soon as the pressure is relaxed the needle, driven back by the spring, regains its normal position, holding the hook upright.

The mechanical contrivances by means of which the cylinder is moved, pressed against the needle board and rotated as the block rises and descends, are most ingenious, and subject to a great deal of variation. They are, however, not essential to the principles of the machine and can be passed over. But

the method by which the perforated cards are adjusted to the cylinder and interpose between it and the needle board must be explained.

Figure 53 shows a detached cylinder and four cards punched with a pattern called a four-lined twill. This pattern repeats on every four lines; accordingly only four cards are needed to weave it. At the ends of the cylinder, close to the perforations, pegs are fixed and holes matching these pegs in size and position are punched in the cards. These pegs hold the card in its proper place, so that its perforations correspond exactly with those of the cylinder.

Each side of the cylinder as it rotates, being covered with a card held close to it by two elastic bands will press against a different set of needles at each of its four movements. The fifth movement, of course, brings the first set of needles again into play. When, however, as is generally the case, more than four lines of design are re-

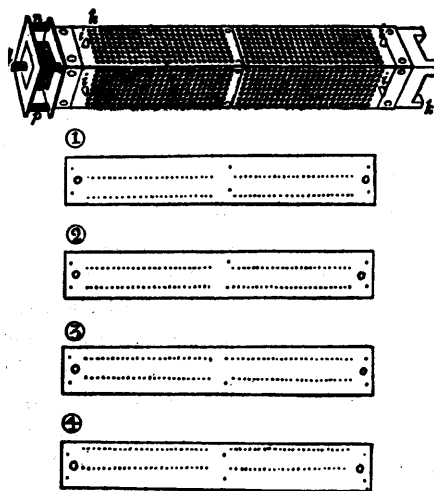

FIG. 53.—Jacquard cylinder and cards.

quired, the cards have to be laced together in an endless band hung upon a rack at the side of the loom, and carried around the cylinder.

The most striking advantage of the use of the Jacquard machine in the textile arts is the facility it gives for a frequent change of design. It is only necessary to take down one set of cards and hang up another in order to change the pattern. The result of this facility was that the early part of the nineteenth century witnessed a perfect orgy of fantastic ornamentation. The manufacturers of all sorts of ornamental silk and fine woolen textiles vied with each other in the number and originality of the designs they could produce. The profession of designer may almost be said to be an outcome of the invention of Jacquard. Previously to this time the master weaver, or some person in practical touch with the looms, had arranged the design, and when once tied up on the loom it was good for a lifetime. But with the introduction of the new draw engine, as the machine was called, all this was altered, and restless change of pattern and fashion was the result.

At first the machine was only adopted in the silk trade for the weaving of rich brocades and other elaborate materials for dress or furniture, but ever since its introduction its use has been gradually extending, all kinds of plain and ornamental textiles being now made by its means, whether on hand or power looms.

As a work of mechanism it is truly wonderful. It can be made to govern all the operations of the loom except throwing the shuttle and actuating the lever by which it itself works. It opens the shed for the pattern, however complicated, regulates the length of the design, changes the shuttle boxes in proper succession, rings a bell when certain points in a design requiring special treatment are reached, regulates the take-up of the woven cloth on the front roller, and works out many other details, all by means of a few holes punched in a set of cards. Its great defects are the dreadful noise it makes, the ease with which it gets out of order, and the difficulty of putting it right. These render it only suitable for factory use, where noise does not seem to matter, and where a machinist is constantly at hand to keep the mechanism in good order.

So far I have traced the development of the hand loom, from its most primitive form to one of a high degree of perfection, as a tool for the skillful artificer. Here I must at present leave it and turn to a brief consideration of the machine loom actuated by steam or other power.

In order to find the earliest recorded attempt to weave by power we must carry our imagination back to the latter part of the sixteenth century and look in on the fathers of the city of Danzig in council chamber solemnly assembled. They are deciding the fate of a prisoner accused and found guilty of the crime of inventing a very



FIG. 44.—CHINESE DRAW LOOM.  
(From an ancient drawing.)

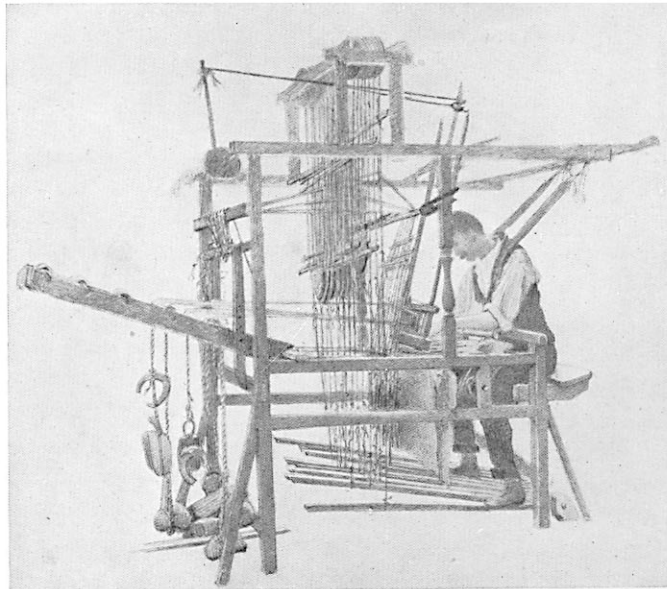

FIG. 54.—NARROW SILK WEAVER AT WORK.  
(From a drawing by the author.)

ingenious machine for weaving narrow tape several breadths at a time.

The council, having carefully considered the machine, and bearing in mind the state of the trade, were "afraid that by this invention a great many workmen might be reduced to beggary." They, therefore, mercifully ordered the machine to be suppressed and the inventor of it to be privately strangled or drowned!

The weaving trade has always been divided into two great branches. The broad weavers made stuffs for garments and furniture seldom less than 21 inches wide. The narrow-branch weavers make ribbons, laces, tapes, braids, galloons, and such like goods, and of course when these were only woven in single widths on hand looms vast numbers of persons were employed in weaving them. There was a great demand for such goods in the middle ages.

Figure 54 (pl. 10) shows a narrow weaver at work on a hand loom. I discovered him the other day in a small trimming factory near Piccadilly Circus. The loom he is working at is an actual survival of the eighteenth century. There are several others in use at the same factory, where braids and trimmings for high-class furniture are always being made.

Attempts were made at various times in the seventeenth century to introduce the machine tape loom, but complaints and rioting prevented them succeeding. It was not until the eighteenth century that prohibitions were finally revoked, and the Dutch bar loom, as it was called, came into general use.

An illustration of this loom is given in the great French mechanical encyclopedia published in 1786. It is reproduced in figure 55.

The reason why the ribbon loom was so readily made workable by power was because it did not require the one movement which has always been the great obstacle in the way of weaving broad webs on machine looms—that is, the throw of the shuttle. Nay, not so much the throw, but the catch of the shuttle.

Figure 56 shows the graceful operation on which good weaving depends, an operation which has never yet been successfully imitated by machinery and probably never will be.

The operations of the loom in weaving are four in number: To open the shed, to throw and catch the shuttle, to beat the weft to-

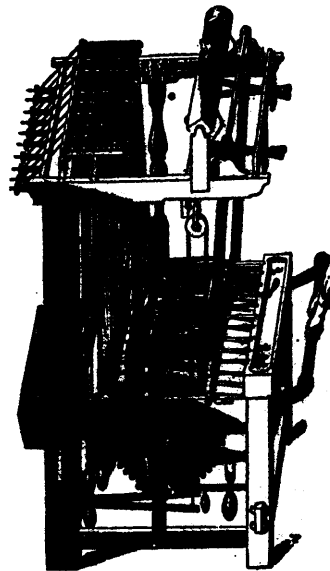

FIG. 55.—Dutch bar loom.

gether, and to wind up the woven cloth. All these, except the second, are comparatively easy to arrange for, even in broad weaving, by means of a power-driven turning shaft furnished with cranks and eccentrics, fitted up in some convenient position in the loom. In narrow weaving the spaces of warp are so small that the passing through of the several shuttles presents no difficulty; consequently the invention of a practical automatic machine loom for narrow weaving was an early one.

Many attempts were made in the seventeenth and early part of the eighteenth century to weave broad webs by power, but they all failed to solve the problem of the shuttle. It has been partially overcome since, but the great defect of the machine loom to-day is in the driving and catching of the shuttle.

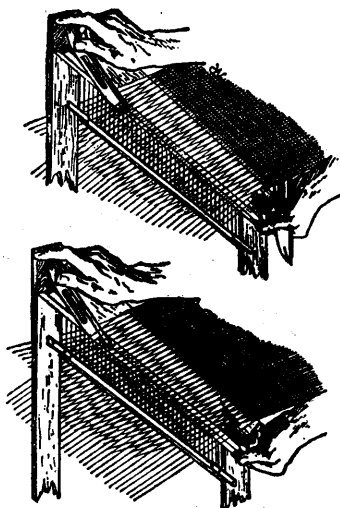

FIG. 56.—Hand shuttling.

The invention which partially solved the difficulty and eventually rendered the machine loom practicable was the fly shuttle, intended by John Kay, its inventor, for use on the hand loom. Its purpose was to enable the weaver to weave, without the aid of an assistant, wider webs than he could manipulate with the hand shuttle.

Figure 57 represents the batton used for the fly shuttle and should be compared with the hand shuttle (fig. 56).

The difference between hand shuttling and fly shuttling can almost be distinguished by comparing the two shuttles used. The hand shuttle is slightly curved and adapted nicely to the position

of the weaver's fingers. The fly shuttle, on the contrary, is rigidly straight, so that it flies along in front of the reed, without any bias, from one end of the race to the other.

Comparing the battons, it is seen that the race block of the fly-shuttle batton is elongated at the ends. On these ends the shuttle can stand clear of the cloth which is being woven, and which is, of course, never wider than the reed.

These elongated ends have a bar of wood so fixed in the front that there is just room for the shuttle to run in and rest between it and the back of the shuttle box, as the elongated end is called.

Above the shuttle there is a thin, smooth iron bar, and on this the driver (enlarged at F), made of tough leather, is fitted so that it will easily slip from end to end of the box. Both boxes are furnished with drivers and are fitted up in exactly the same manner. The two

drivers are connected by a thin, loose cord, having at its center a handle. The loose cord is suspended from the bar above it merely in order to keep it off the level of the web. To drive the shuttle across the race, the weaver grasps the stick, after placing the shuttle in the box near the driver, and, with a sudden jerk to the side he wishes to send the shuttle, pulls the driver along the bar with just sufficient force to drive the shuttle into the opposite box. By a slight turn of the wrist—which is difficult to acquire and impossible to imitate by a machine—the opposite driver is brought forward to meet the shuttle as it enters the box. If this be properly done there will not be the least rebound, and the weft will be laid evenly and straight. If, on the contrary, the shuttle be allowed to rebound, the shoot of weft will be loose, and when beaten down by the reed will show kinks and loops. Moreover, the edges of the web will be uneven.

Previously to this invention all attempts to pass the weft through the shed in machine looms failed to achieve anything like the speed of the hand-thrown shuttle; consequently they could not compete with the hand loom. Even when the fly-shuttle method was adopted the difficulty of catching the shuttle baffled the skill of inventors for many years.

The attempts of inventors to produce an automatic broad-weaving machine resulted in the construction of many weird though ingenious contrivances bearing more or less likeness to the hand loom in general use. Many of these were patented by their inventors, but failed to prove practically useful. It was not till 1786, when Dr. Edmund Cartwright devoted himself and his fortune to mechanical invention, that a practical broad-weaving power loom was evolved. Dr. Cartwright established a weaving and spinning factory at Doncaster, but after spending £30,000 and nine years in experiments he was obliged to give it up. He had, however, succeeded in devising a power loom for plain weaving, which it was believed could compete with the hand loom. Several of his looms were bought by a Manchester firm and set up in a factory. They are said to have performed their work well, but the factory was, shortly after its starting, burned down by an infuriated mob of hand-loom weavers.

Figure 58 is a photograph from one of Dr. Cartwright's designs for a power loom. A careful examination of it and its specifications shows that the doctor had many ideas which were long afterwards adopted by improvers of power-loom machinery.

Figure 59 is a drawing of a machine loom constructed by a Mr. Horrocks a little later than Dr. Cartwright's time. It is said to have become largely used. It more closely resembles the fly-shuttle hand

loom than any of the other inventions. I should think it was only capable of weaving very faulty cloth.

By the end of the eighteenth century, it is said, there were 20,000 power looms at work in Great Britain against 250,000 hand looms. The power looms, like the hand looms, were constructed mostly of wood, and must have been clumsy and uncertain in their performances. Owing, too, to the greater strain of power weaving they must have quickly worn out.

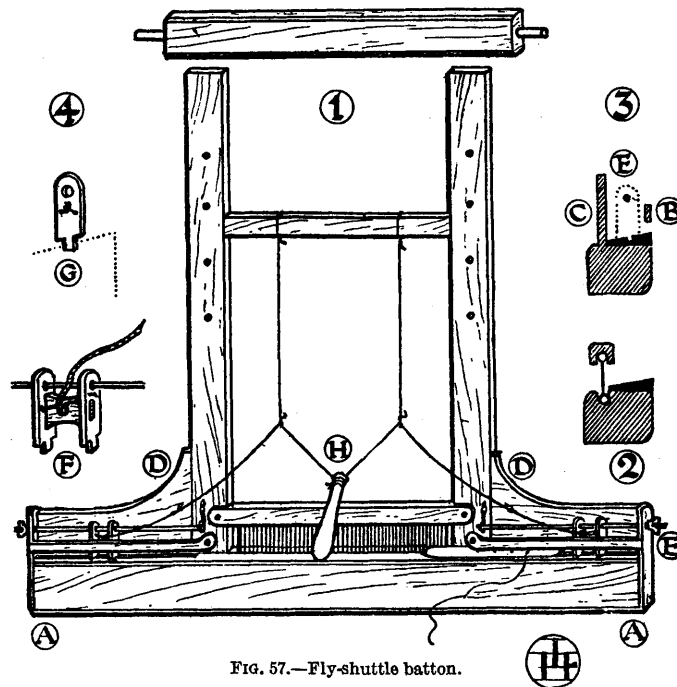

FIG. 57.—Fly-shuttle batton.

It was a long time before a convenient form for the power loom was generally adopted. Curiously enough, the form at length settled on was designed for a hand loom in 1771.

The inventor of this loom (fig. 60) was a Mr. Almond, who exhibited and worked it before the Society of Arts, and received a prize of £50 for his encouragement. Its chief feature is the inverted batton. It has also extra rollers, by means of which the length of the loom is greatly diminished.

A power loom erected for Mr. Monteith, a Glasgow manufacturer, about the beginning of the nineteenth century by a loom builder named Austin is extremely like Almond's hand loom.

Mr. Austin presented a model of this loom to the Society of Arts, of which figure 61 (pl. 11) is a representation.



Having settled on a general form suitable for the power loom, inventors next directed their attention to strengthening it and perfecting, as far as they could, its various parts. Take-up motions, contrivances for detecting broken threads, quickly stopping the loom, throwing the shuttle, etc., occupied their attention, and the loom became more and more accurate in its different performances as time went on.

Iron took the place of wood all through the machine and the loom, actuated by steam power, has by now become, except in the matter of working the shuttle, a very perfect automatic machine.

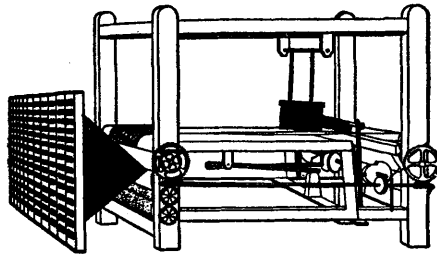

FIG. 58.—Dr. Cartwright's machine loom.

Figure 62 (pl. 11) is a modern steam machine loom for weaving silk. You will notice at once how the levers for driving the shuttle, and the shuttle boxes, have increased in size and strength. It was found that in order to catch the shuttle and prevent it rebounding its entry into the opposite box had to be resisted. This rendered it necessary that the shuttle itself should be enormously increased in weight, and that

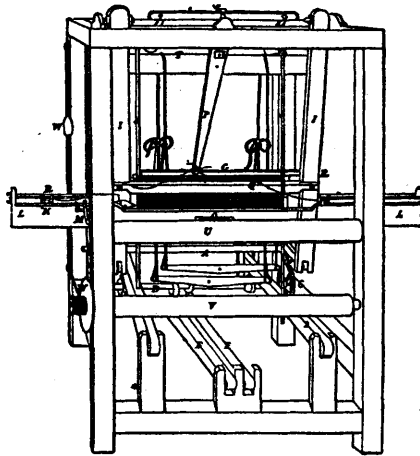

FIG. 59.—Horrocks's machine loom.

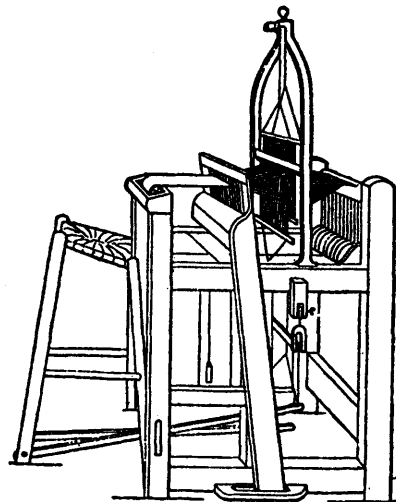

FIG. 60.—Almond's loom.

great force should be used in driving it. Half the power expended in actuating the machine loom is required thus to drive the shuttle into the opposite opposing box.

The addition and adaptation of the Jacquard machine to the power loom was not attempted till late in the nineteenth century, but when that was done the loom had arrived at the point of development at which we find it to-day.

A few months ago my attention was called to an illustration in the *Manchester Guardian* which represented a new weaving invention, and, on reading the description of it, I found that the inventor—Mr. Whalley, of Clitheroe—claimed to have solved the problem of the shuttle, which I have pointed out has been the chief obstacle in the way of weaving by power.

Figure 63 (pl. 11) is a photograph of the new loom, which appears to me to be likely to revolutionize the construction of machines for weaving by power.

Although at first sight this loom seems to be altogether different from previous inventions, an examination of it proves that in most essential points the tradition of weaving, which I have attempted to explain, still governs it. Three great advantages are claimed for it—(1) it is practically noiseless; (2) the weft has no jerk or strain upon it; (3) very little power is required to drive it. In addition to this, webs of between 11 and 12 feet wide are woven on it.

There is not time for me to give an adequate description of this important invention, but I must notice its salient points, and show (1) how it differs from the ordinary power loom and (2) how the traditional principles of weaving are still carried on in it.

First, as to points of difference: All the operations of the loom are worked out by its simply turning on its own accurately centered axis.

By an uninterrupted circular movement in one direction the warp is drawn off the warp beam, the shed is opened, and the weft inserted, the weft itself is gently pressed close instead of being beaten together, and the woven web is delivered and rolled on to the cloth beam without any strain or jerk whatever.

There is no shuttle. A case for the flexible cop of wound weft takes its place. The cop itself is of enormous length and holds a hitherto unheard-of quantity of yarn.

While the whole loom and its fittings revolve, the cop case remains stationary, balanced in the shed, and allows the weft to be drawn off it continuously in one direction, as, at each revolution, the successive sheds are opened. This forms, of course, a spiral thread in the woven cloth, the cloth itself being produced in the form of an enormous tube. As the cloth passes on to the cloth beam an automatic knife cuts it at a place where specially woven doup selvages are made.

So far all is new. The rest of the mechanism is an ingenious rearrangement of the traditional parts of a loom. The description of these essential parts requires a diagram of a section of the loom, which we have in figure 64.

In the center of the section is the steel axis, which runs the whole length of the loom.

The perforated comber board, instead of being straight and horizontal, as in the ordinary loom, is circular, and is duplicated, the holes being most accurately pierced.

The holes in these circular comber boards are very close together, and there are as many holes as there are threads of warp.

In each of these holes there is a long steel needle, with its eye in the center, the needle itself being rather more than twice as long as the space between the two comber boards.

These needles fit loosely into the holes of the comber boards, so that when they reach, as the loom revolves, a position above the horizontal center of the machine they rest against the central core of the loom.

But when in turn the needles come below the horizontal center they project through the holes of the outer perforated circle as shown in the drawing.

A thread from the warp beam is drawn through the eye of each needle, and, when passed through the circular reed and fastened to the cloth beam, will, of course, follow the movement of the needle as it falls against the core at the top or projects through the holes of the outer comber ring. This is shown at Nos. 3 and 4, which are longitudinal sections.

An endless band of cards, similar to those used for the Jacquard machine fits to the outer rim and governs the design. Where these cards have holes in them the needles fall through and draw down the warp thread entered in them, but where the card is plain the needle retains its position. This is shown at No. 5, where an open shed is represented.

No. 2 shows the cop of weft in its case in position for working, where it is retained by two smooth bowls of bosses fixed in their places on the stand or underframework of the loom. The opened shed surrounds the cop case, passes along it, and when it leaves it, of course, incloses the weft.

By an arrangement at the top of the loom the reed is slightly pushed forward so that it gently presses the weft into its place as it passes a certain point. Very little pressure is sufficient, as only a few inches are affected at a time.

Time forbids me to attempt a description of other details of the circular loom, some of which, no doubt, will be altered and improved. But sufficient has, I hope, been described for the general idea of the machine to be understood, and its great achievement, the continuous

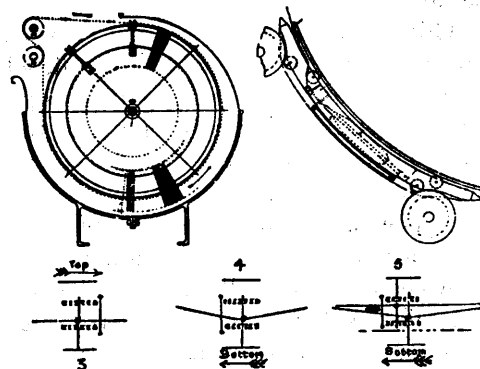

FIG. 64.—Section of Whalley's loom.

wefting contrivance, to be appreciated. Although the hopes of the inventor of this circular loom may not at once be realized, I shall be surprised if the principle on which it works does not eventually become universally adopted for power-weaving machines, especially for plain or small-patterned webs.

Weaving in vast quantities, and cheaply imitating in inferior materials rich damasks and brocades of important and elaborate design is, I hold, neither wise nor desirable. The use of machine looms for this kind of work is therefore to be deprecated. The tender manipulation required for weaving the varying textures of the finest webs made in the eighteenth century, and in China and the East generally, is only possible on a loom as sensitive as the perfected draw loom, and by a craftsman who, understanding every detail of the mechanism, is capable of controlling it. If such perfect work be required it must be done on a hand loom.

This loom, however, need not be as cumbrous as the old draw loom nor as noisy and intricate as one fitted with the Jacquard machine. If I may don the mantle of the prophet, I should say three things will be retained and will continue the tradition of the past in the hand loom of the future. With an indication of these I must conclude my lectures.

1. The skillful manipulation of the hand shuttle for work not too wide for it, and of the fly shuttle for broader webs, can not be improved upon. It will therefore be retained.

2. The perforated comber board (fig. 45) which, as I have showed, was an ancient Chinese invention, must be retained. Probably, however, some arrangement of metal needles, such as those of the circular loom just described, will be substituted for the string leashes with their mails and lingoos. But all the upper complications of strings and cords will be dispensed with.

3. The principle of working out the design by punching holes in a band of cards will be retained, although the Jacquard machine itself will, I imagine, be superseded by an electromagnet placed above the comber board. This magnet will attract the metal needles and raise the warp, some arrangement being made so that only those needles wanted for making the required shed will be raised.

Everything else may go, and new contrivances be introduced, but it is on some such hand loom as this that I can imagine the master weaver of the future being able, not only to produce webs as exquisite as those of the best weavers of the past, but to carry the art forward to a higher degree of perfection than it has ever yet attained.

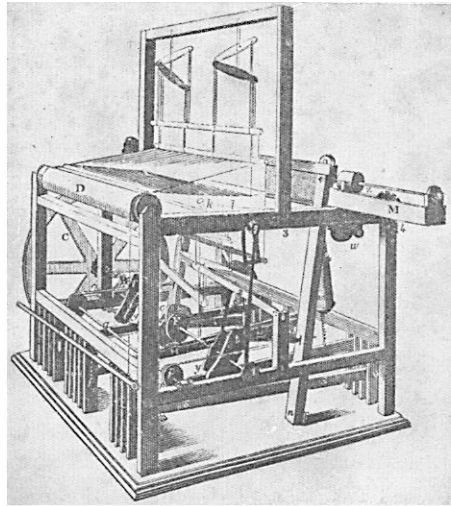

FIG. 61.—AUSTIN'S MACHINE LOOM.

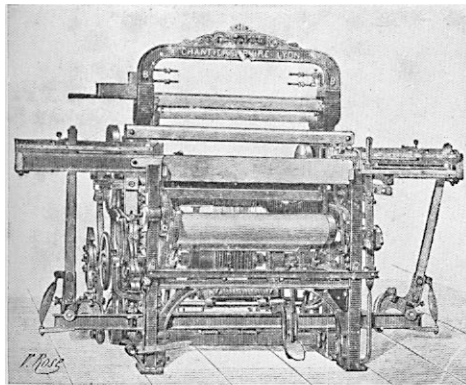

FIG. 62.—MODERN MACHINE LOOM FOR SILK WEAVING.

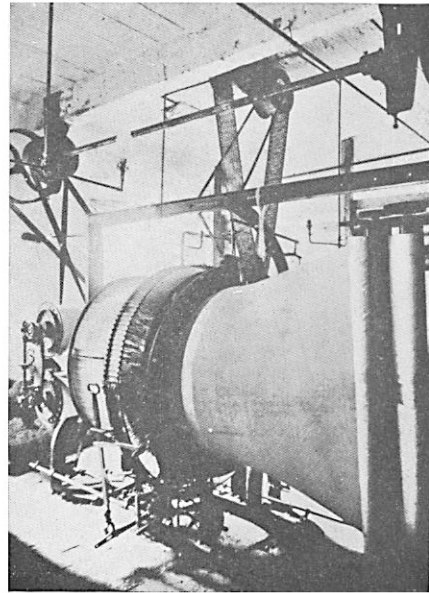

FIG. 63.—WHALLEY'S CIRCULAR MACHINE LOOM.