

suits there is still less opportunity for change. In the case of one-piece or union suits, which are integral from neck to ankle, these restrictions also exist and are, if anything, more arbitrary than with the two-piece styles.

Under such conditions it is evident that any very radical innovation in the cut or shape of these garments is out of the question; so the designer's efforts must of necessity be confined to the minor details of texture, finish, color, etc. In this field, however, his art has the fullest scope, for there is no end to the variety of effects that are possible by the use of the various trimming materials, by themselves or in combination; or when introduced as contrasts with the fabric itself; and it is principally these essential details that have brought about the present advanced state of the art. The chief fundamental that must be recognized is that the wearers of these garments demand something that shall be of an even thickness throughout, so whatever may be superimposed in the way of bands, facings, etc., must not be of any appreciable thickness that will cause the garment to appear bulky in any part.

The basic fabric, having been previously determined as to weight, firmness, etc., is sufficient of itself for the requirements of the season, and any extra thickness beyond this often proves uncomfortable to the wearer.

The seams that are introduced to unite the several parts into a garment must also be flat as well as strong, and without any unnecessary ridge or corded appearance. These are prime essentials, which may be considered as standardized, and having provided for them in a satisfactory manner the final detail of finish may be considered. A certain amount of this, is, of course, indispensable, as it is required for the practical purposes of fastenings in the form of buttons, lacings, etc., and as bindings, facings, hems, etc., for protection of the several openings and extremities of the garments. In selecting the materials for these purposes, however, many pleasing effects are possible, and they may be made to serve in a decorative sense as well as being utilitarian.

Selection of Materials. In selecting the nature and quality of fiber or material from which the fabric will be made, it is necessary that the detail of color should be considered in conjunction, because if a specific hue or shade has been predetermined, and a dye or other

artificial agent is necessary to produce the desired result, the especial fiber known as the most favorable vehicle must be chosen; for among the many generic dyeing agents, or their mordants, some are more perfectly adapted to a specific fiber than others. If a natural color is desired, that fiber which has the cleanest appearance when in this state must be selected.

Having determined the fiber, color, and gauge of the fabric, and having a finished piece of cloth before him, the designer's task is to shape the pattern or cut of the garment, and to decide on an amount and quality of finish or trimming that seems necessary and appropriate. This is essentially the chief's province, in which there is recourse to no assistance excepting that rendered by the makers of whatever finishing material he needs, such as facing, bands, binding, lace, buttons, etc.

Style of the Garment. The style of underwear in most general use is the two-piece suit, consisting of shirt and drawers, or vest and pants. The one-piece or union suit, however, is fast coming into vogue, and it has several points of superiority that appeal to a large class of users. While there is no intention to establish a comparison, one, and probably the principal, advantage of the union suit may be mentioned.

This is the absence of a double thickness of fabric around the lower part of the body and hips, for, as the garment is of one integral piece from neck to ankle, it adds but a single thickness over any part of the body.

Style of Finish. In selecting an appropriate amount of finish for all styles of these garments, a great deal of care and taste is required, for if too much finish is imposed, or if it be gaudy, the desired effect is at once destroyed; this being especially true of the more expensive grades. In the detail of neck finish, for instance, while a novel effect is always sought for, either by the aid of lace, binding or a piece of the fabric itself having been knit with contrasting stitches, any material that produces a poor effect is at once seen to be out of place. This is also true of the front facing of shirts, and bands on drawers.

The buttons also are made in an endless variety, some being very beautiful, and they assist very materially in producing a dressy effect.



VIEW IN ONE OF THE KNITTING ROOMS AT THE WAYNE KNITTING MILLS, SHOWING 18-SECTION FOOTER
AT WORK ON HALF HOSE

As regards the color scheme of the garment, there are probably as many varying theories on this subject as there are wearers of the garments. So the problem is to exhibit only that which will not offend. An effect that is pleasing has trimmings of a slightly dissimilar shade from the basic color of the integral garment itself. Many times the very simplicity of a design serves to attract attention

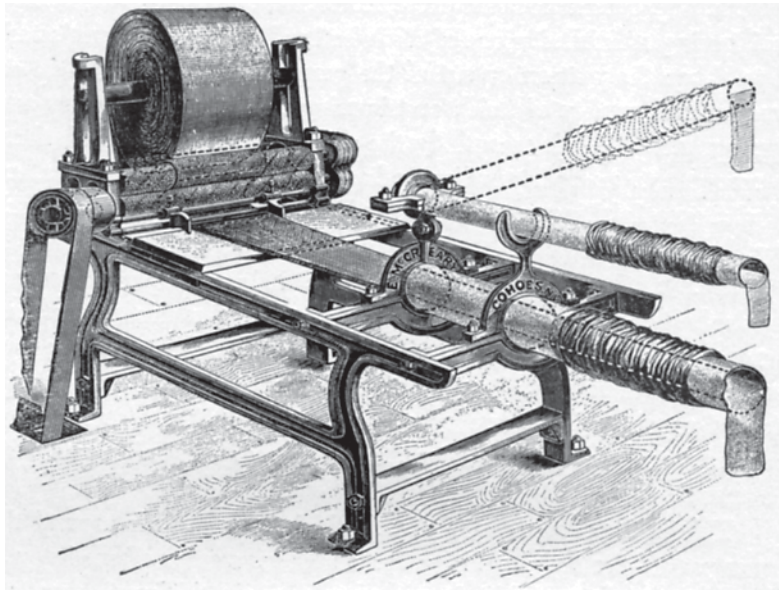

Fig. 1. Turning and Winding-up Machine.

to a fabric that otherwise would fail of notice, even if the greatest skill had been devoted to its every process of manufacture.

FINISHING FLAT GOODS

The manner of handling knit goods, and the various operations required in the process of finishing, is about the same in all kinds of goods, either shirts or drawers, but for convenience a dozen shirts, followed through the mill, will illustrate the successive processes they undergo. The system of tracing the garments with the Stetson coupon check is perhaps regarded as the best and most reliable system for that purpose.

Turning the Cloth. When the rolls of cloth are removed from the take-up, the right side of the cloth is inside the roll; that is, the

inside of the circular web of cloth as it leaves the needles on the frame presents a more sightly appearance, showing as it does the wale or ribs formed by the stitch, while the outside of the fabric presents the annular courses formed in the knitting operation. The beauty of the stitch formed on the ribbed side of the cloth distinguishes it as the right side or face. This requires the web to be turned inside

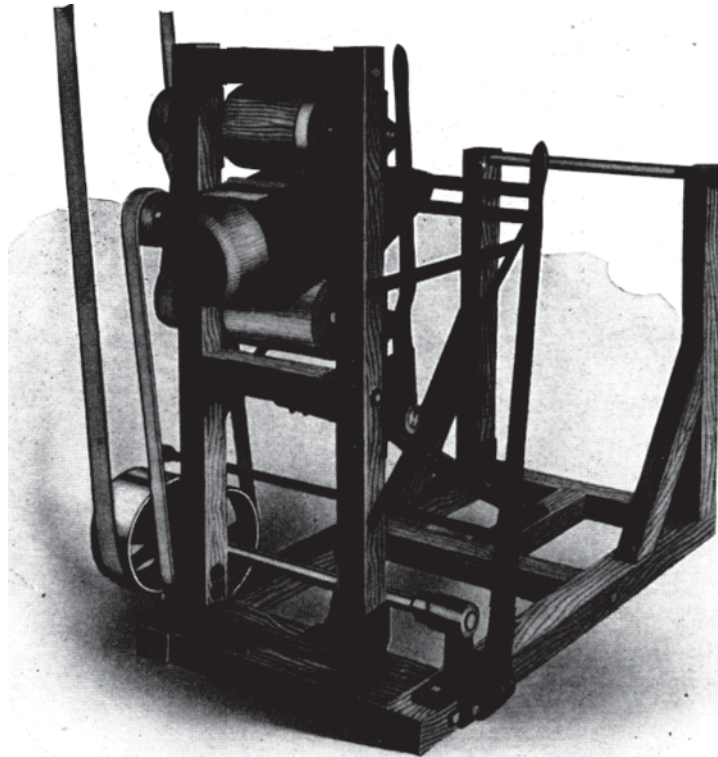

Fig. 2. Leighton Machine Co's. Knit Web Turning Machine.

out, and it is usually most practical to turn it before it leaves the knitting room. The accompanying cut shows very clearly the mode of accomplishing this operation by machinery. (See Fig. 1.)

The web of cloth is drawn on the tube or cylinder until the other end can be introduced into and drawn through the inside, and started around the roll at the further end of the machine, and

the power applied and the cloth rolled up in shape to be delivered to the cutter. The machine is simple and readily comprehended by reference to the illustration.

The Leighton Machine Co.'s knit web turning machine is an important improvement in the process of turning the web. It is intended to be set up at the end of the turning tubes now in use in knitting mills and to put the roll of webbing on the tube ready for the rolling up machine, to take it off through the tube (thereby turning the web) and roll it up again. This is a satisfactory device for putting the webbing on the turning tubes.

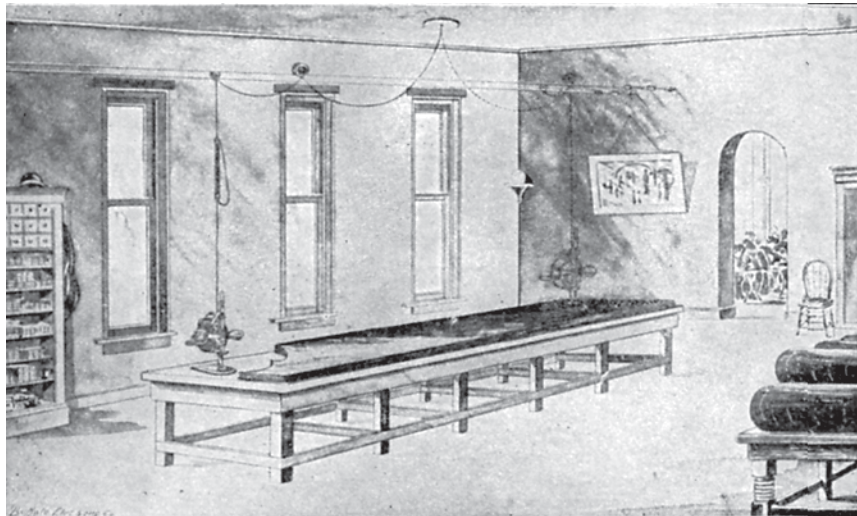

Fig. 3. Eastman Electric Cloth Cutting Machine Table.

Cutting to Shape. The cloth, now being right side out, is turned over to the cutter, who pushes an iron rod through the center, and places it in a rack, provided for that purpose, at the head of the cutting table.

If the cutting is done in the old way with a large, long knife pushed up and down through a slot in the table arranged to suit the size and style of the garment required, the cutter draws from the roll such a length as he requires, cuts it off, and repeats the operation until he has as many lengths in a pile, evenly distributed on top

of each other on the cutting table, as he may desire. After marking the top of the pile with a pattern corresponding with the slot in the table, he proceeds to "whip-saw" or cut out the sections of the garment as marked out with the pattern. The smaller sections are cut and fashioned with hand-shears, as also are the shoulders "sloped" where the sleeves are to be fitted in.

Finishing Processes. After a dozen bodies, twenty-four sleeves, twenty-four cuffs and twenty-four half borders have been prepared, they are tied up in dozen lots and turned over to the loopers, who loop on or join the cuffs to the bodies, the rib-tails to the bottom of the shirts, and join the shoulders without leaving a seam, as they are joined loop for loop in a manner not easily detected. They may be sewed together very nicely, but the point of joining is never so smooth and slightly as by the looping process.

The seamers then take the garments in hand to seam up the sleeves and join them to the bodies. The inspectors and menders then look them over and attend to what mending is necessary.

If overseaming the cuffs is in vogue the garments then go to the overseaming machines, to have the cuffs and half borders joined on the edges, after which they go to the washroom and are scoured and fullled. If they are to be bleached they are placed in the bleach house over night wet, and are given a sulphur bleach, taken out in the morning, rinsed and sent to the boarding room where they are boarded on forms of the proper size as designated by the yarn marks in the garments.

After drying out in the dry room or drying machine, and removed from the boards, the garments are sent to the finishing room where the process of finishing begins by girls looking over them to see if the sizes are properly sorted, and stamping the sizes on the skirt of each garment, attaching the Stetson coupon tag and sending them to the neck marker, who marks the neck with a "kicker," or in an up-to-date mill with a power marker.

After the neck flaps are cut the stitcher performs her operation of stitching down the flaps, and takes off the first coupon, it being the first piece-work performed on the garments. They are now carried to a cutting table, the fronts marked, cut down for the button stays and button hole facings, and are then turned over to the facer, who sews on the facing, detaches her coupon from the tag, and

passes them over to the twin-needle machine operator, who covers the raw edges of the flaps. The dozen then goes to the finishers, who put on the button stays and further complete the garment with binding of such quality as designated on the stub end of the check.

The button-holer now takes the dozen in hand and makes the button holes, spacing them and trimming off the threads. She turns them over to a little girl who marks them for the buttons and carries them to the button-sewing machine, where the buttons are sewed on and the threads trimmed off.

They now come under the eyes of the inspectors, or 'lookers-

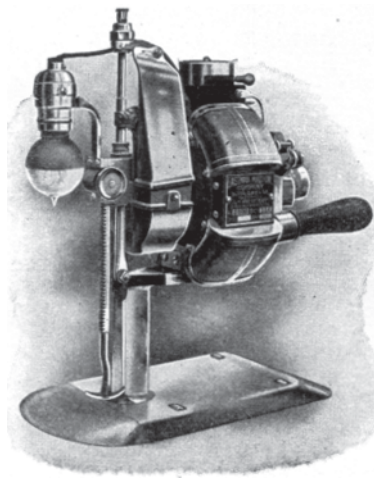

Fig. 4. Eastman Electric Cloth Cutting Machine.

over, who look them over carefully, trim off all loose threads and shaking each garment, send them to the press-room, where they are carefully folded in papers or press boards in dozen packages and put into the press, in which they are left for three hours under a pressure of 3000 pounds or more. After being taken out of the press and the press-boards removed, they are carefully scanned by girls, who throw out all imperfect goods and fold

the perfects or *firsts*, in proper shape to fit the boxes, after which they are boxed and labelled, ready for the shipper. A well regulated and well managed mill ought not to have more than 2½ per cent of seconds, even on a medium grade of goods.

Equipment and Arrangement of the Finishing Room. A well equipped, up-to-date mill today has several features in the finishing department that the larger number of the mills have been slow to adopt. In these improvements are included an electric or power cutting machine, taking the place of the old way of cutting with a knife following a slot in the cutting bench and pushing by hand with

an up and down motion as with a saw. Another departure is in the method of drying, a complete drying machine being substituted for the old way of a large room given up to drying and wasting heat.

The arrangement of the tables—cutting, inspectors', makers', and other tables as well as the machine tables—depends greatly on the size of the finishing room. The cutting tables should be in close proximity to the knitting frames. If the cutting is done on a floor

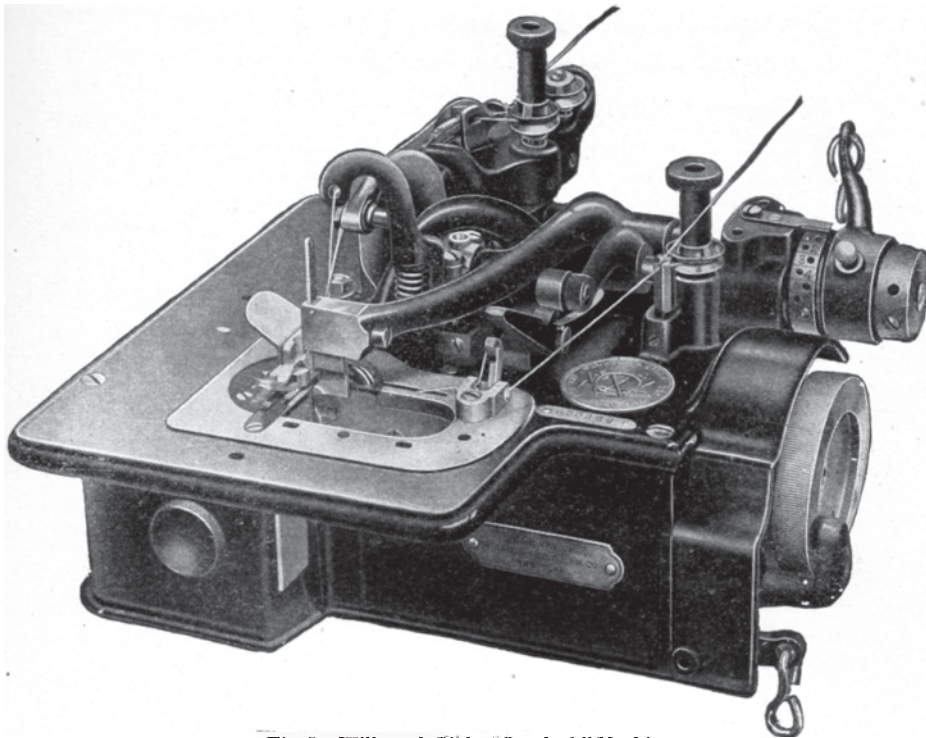

Fig. 5. Willcox & Gibbs "Overlock" Machine.

above that where the loopers are, a chute can be arranged to slide the goods down near the loopers after they are cut and bundled in dozens. To each bundle should be attached a patent tag, on which is printed a coupon for every operator who works by the piece to detach, in order to show the number of dozens she has done. The cutting may be done in the finishing room, if more convenient on account of the floor space. If there is space in the knitting room, it

is more desirable to do the cutting there, the rolls of cloth being more awkward to handle than the bundled dozens.

The seamers should be near the loopers. The nearer all these several operations are to each other, the less day-help is required to handle the goods, and it is folly to have operators of machines running after their work while their machines lie idle. It simply means more machines and more operators, and it is wiser in more ways than one to have little girls do what marking, and other preparatory work which they are capable of doing, carrying the work to the operators and taking it away, thereby getting the full production from machines.

EQUIPMENT FOR FINISHING 100 DOZEN FLAT GOODS
WILCOX AND GIBBS SYSTEM

A good finishing equipment for finishing 100 dozen men's or ladies' fine underwear flat goods, embodying the "Overlock" seam and hem of the Willcox & Gibbs Co., may be as follows:

One electric or power cloth cutting machine, with shirt and drawer patterns.

Eight Beattie double or lock-stitch loopers.

Three Wilcox & Gibbs "Overlock" machines.

Drying-boards; the number required depending upon the weight of goods and methods of drying.

One Kennedy's power neck marker.

Patterns and shears for trimming.

Six Willcox & Gibbs automatic finishers.

One catstitcher.

Six zigzag machines, for suspender tapes and covering gussets of drawers and covering edges of cloth left after running necks.

One button-hole machine.

One button sewing machine.

Three two-needle machines, for double row of stitching on outside.

One single-needle machine.

One Crawford power or hydraulic steam press, with press boards.

One rib cutter.

One Kennedy automatic band cutting machine.

One irregular form-cutting machine, with dies for irregular shapes.

One paper cutting machine for cutting domets, etc., into strips, stays, bands, etc.

One power eyeletting machine, for setting metal eyelets in drawers.

If the drawers have straps on the back with two sets of buttons and button-holes to change the waist size, no eyelet machinery is needed. If a tape or lacing is used, the eyelet may be either a metal

eyelet or stitched eyelet, the former calling for a power eyeletting machine, the latter for an eyelet stitching machine.

It is still a custom in some mills to use end-sewing machines to close the cuffs and anklets, but this is not necessary, the present methods of making the seams closing the cuffs properly.

UNION SPECIAL SYSTEM

An equipment for finishing 100 dozen men's or ladies' fine underwear, flat goods, say half shirts and half drawers, on the Union

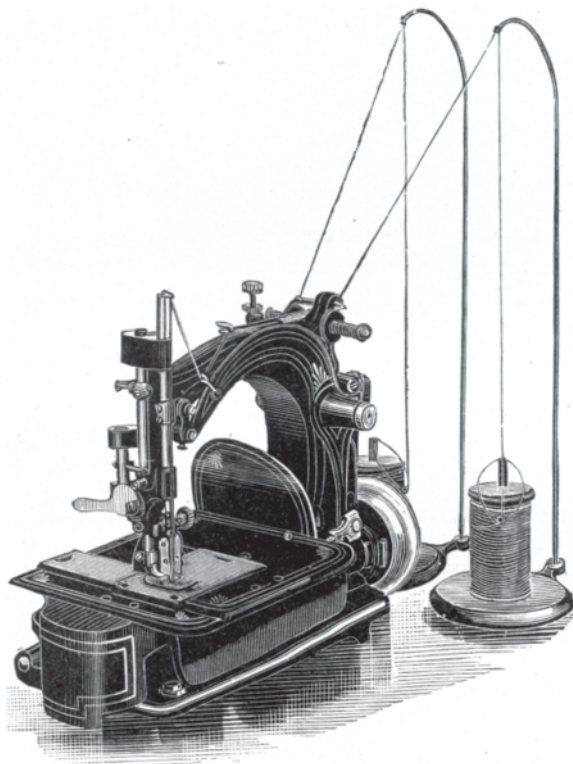

Fig. 6. Dewees Seaming and Trimming Machine.

Special system, should have the following machinery, although, of course, the weight of the goods may make a slight difference:

- One electric or power cloth cutting machine, with patterns.
- Eight Beattie loopers or turning off machines.
- Three Union Special seamers.
- Drying boards—the character of work will determine the number.

One Kennedy power neck marker.
 Patterns and shears for trimming.
 Five Union Special finishing machines for shirts.
 Six Union Special trawer finishing machines.
 One catsitching machine.
 One button-hole machine.
 One button sewing machine.
 One strapping machine, for sewing suspender straps to drawers.
 One Union Special single needle ornamental machine, for making pearl edge on binding.
 One eyelet sewing machine, for stitching round eyelets, or one power eyeletting machine for metal eyelets.
 One Union Special two-line taping machine, for covering back seam of drawers with tape.
 One band stitcher, for stitching drawer bands together.
 One twin-needle machine for necking.
 One McCreary rib cutter.
 One Kennedy automatic band cutting machine, for stays and facings.
 One Gem paper cutting machine for cutting flannels domet, etc., into strips.
 One Kennedy power cutter, with dies for irregular shapes, for cutting stays, drawer bands, forms, gussets, etc.
 One Crawford power steam press, with press boards.

The Finishing Machine Table. Because of the exacting requirements now existing in high-speed sewing machines, it will be realized how vitally necessary it is to the most effectual performance of these machines, and to prolong their usefulness, that a solid support or foundation should be provided. Too often it is the case that the sewing machines are neglected with the result that their full efficiency is never obtained, and they must be overhauled much sooner than would be necessary if the table were of substantial construction, and the transmitters, shafting and pulleys supported and aligned in a workmanlike manner.

Of the sewing machines in use at the present time, the greatest number are either necessarily complex in their construction, and consequently of considerable weight, or are run at a high rate of speed, which is often more than equivalent to the weight factor in its ultimate effect on the table. Many machines combine both these features—weight and speed—which, of course, means a double tax on their supporting structure.

That class of machines which includes those used for button-holing, button-sewing, and strapping, is an example of the heavy type, and their most important function is the stop-motion which

is made necessary by the nature of their particular operations. These machines are run at a comparatively slow speed, but the unremitting succession of shocks from the stop-motion is a factor which imposes the hardest kind of service on the table.

All seaming machines, and some of those used for finishing are comparatively lighter than the class just mentioned, but the load which they contribute is added to by the high speed which is required from them. About the only machines in use at the present period that may be called *light*, as well as light running, are the small, single-thread finishing machines, and if those were the only ones to

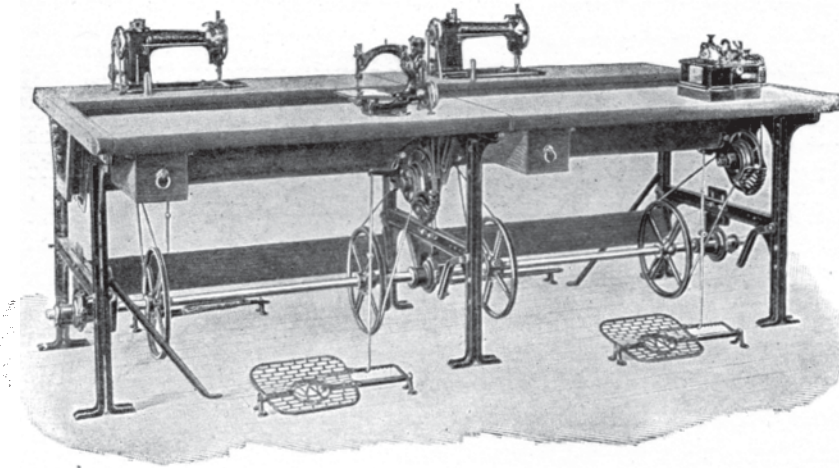

Fig. 7. Willcox & Gibbs Sewing Machine Table.

contend with, the ordinary light, wooden table would no doubt suffice.

Recognizing the requirements as they now exist, however, it becomes most important to consider them carefully, and provide a foundation for the machines that will meet the new conditions, not only with reference to the essential of convenience, but especially in regard to the required amount of strength and stiffness to adequately absorb any amount of vibration that may develop. The result would insure increased general efficiency of the machines, their usefulness would be prolonged indefinitely, and the table itself would be practically indestructible.

There are, of course, many differing ideas as to how a table should be constructed. A strong, wooden table has many good points, and so has one with iron legs and wooden top. The latter meets with the most general favor, however, and seems to embody a greater number of desirable features than any other. With reference to this subject a set of drawings has been prepared (See Fig. 8) that illustrates several views of a table which is designed to embody, in the simplest form, many features that have been proven to be essential, together with others that are somewhat novel; and it is believed that a combination of this description would effectually meet all of the essential conditions that may arise. The design is susceptible of modifications to suit the individual needs of each mill, or as the course of the product through each department may necessitate, but the general scheme will be readily understood.

In this table the legs are of cast iron, the main feature of which is a straight, tubular form of post that is designed to be located as nearly as possible under the point of load or stress which the table top receives from each line of machines, thus securing the most direct support and connection between the machine bases and the floor. The feet of these posts are extended horizontally from opposite sides of each post in a line parallel with the length of the table, and in this manner assist materially as braces in this direction. Strong lag screws which enter the joists or stringers where possible ensure a most effectual fastening to the floor at these points.

A feature which is second in importance only to a good floor fastening is that of supporting the main shaft in its bearings, for in a long stretch of table the corresponding length of shaft must carry a considerable weight of iron in the form of pulleys and couplings, and as this factor is always greatly exceeded by that of the straining belts, which are necessarily short and must therefore be kept at a tight tension in order to transmit the required amount of power to each machine, the resultant of these two forces, weight and strain, becomes of great moment.

To provide an adequate resistance against these forces at this point, therefore, it will be noticed in the drawings that the main, or lower cross rail web has been quite heavily ribbed both top and bottom, making it of the I beam form in section. In addition to this provision for strength in the rail itself, its ends are seen to depend

gradually to their points of connection with each tubular upright member, thus giving the rail an arch form in outline, and providing ample strength for its purpose in any direction.

The well known provision for adjusting each hanger in its rail for the purpose of aligning the shaft is shown in section.

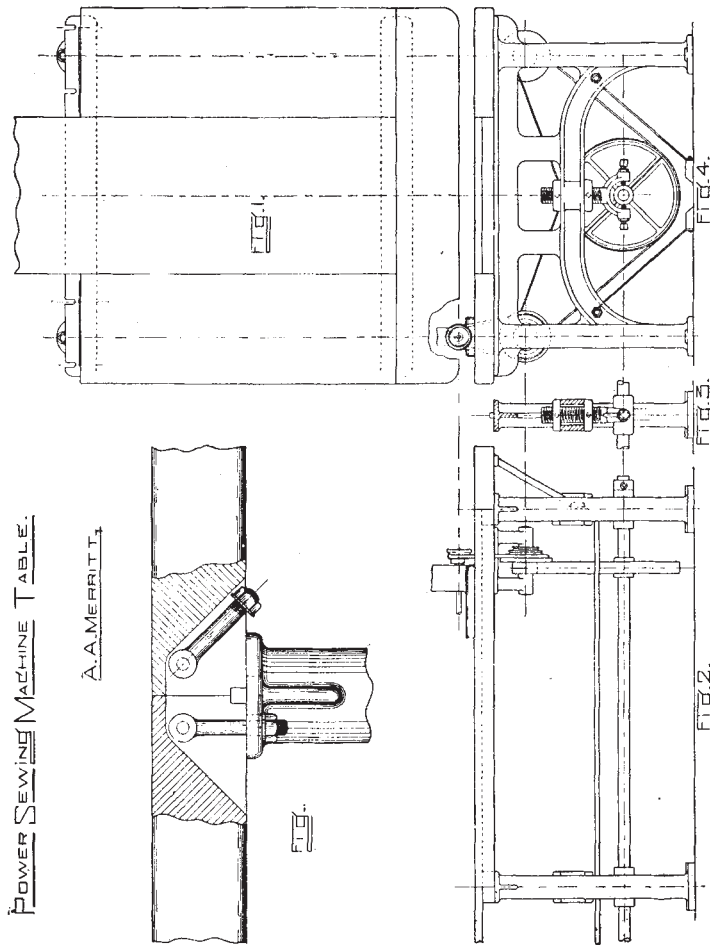
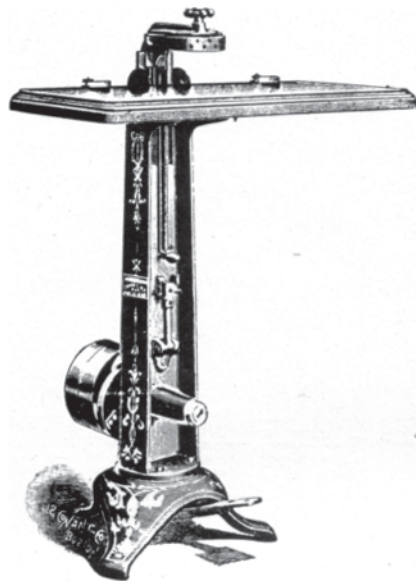

Fig. 8. Merritt's Power Sewing Machine Table.

The upper cross rail which supports the wooden top, is provided with a wide flange on its upper edge, through which the screws that secure the top are passed. Its mid-section is supported through two extensions of the web which connect respectively at two points on the

upper side of the lower rail. Both these rails and the two tubular upright members are combined in one integral casting, and there are no joints for the purpose of adjustment whatever, excepting the one for the purpose of aligning the shaft.

It is no doubt convenient, and sometimes necessary, that vertical adjustment for the table's top be provided, but where it is not necessary, it is doubtful if this provision is a practical one, for if not fastened



Kennedy's Power Neck Marker,

very securely, such adjustable joints are soon out of place, and the table's top deflected thereby as badly, or worse, than any floor would settle in years. So if a table can be erected without them, it would be rigid to the utmost limit, and, thereafter, never need attention except as the building itself might change, and in that event any change would affect all points of the table equally, so if the shaft and the top were originally in perfect alignment their relation would never change.

A section of the top is shown, the central portion of which is made of one-inch stock, approximately, and extends continuously over as many pairs of legs, or supports, as its original length will permit. The two outer parts of each section, however, are intended to be of much thicker stock—say three inches—and will extend only from one leg to the next adjacent one, thus providing a separate top section or base for each machine and its transmitter.

The ends of these short sections are designed to rest on the upper horizontal flanges of the two adjacent cast iron legs in such a manner that two of the tops will meet and make a joint in the centre of one flange, and, if suitable detachable fastenings are provided, it is possible to remove any section with its machine and transmitter undis-

turbed, and replace them between any other pair of legs. This makes it possible to quickly substitute one machine for another at any point on either side of the table whenever it is found necessary or desirable to change the order of operations through the department, and not be obliged to pass the dozens back, or cross the table.

A trough or depression in the top has not been provided in this table, for the reason that this feature has always seemed to disclose as many defects as advantages, mainly in the fact that it was a very convenient receptacle for many forms of waste material, such as poorly wound cones of thread, or bobbins, defective binding, dirt, etc.

One other item in the table's equipment is that of supporting the spools or cones in a position that will most favorably deliver their thread to the machines. This position would seem to be somewhere overhead, but within easy reach of the operatives, and a long central rack may be provided for the purpose, which would be supported at intervals from the table's top, or suspended from the ceiling. The latter plan would be preferable as the rack would not then be affected by any vibration from the machines through the table.

ADJUSTMENT AND OPERATION OF FINISHING MACHINES

The adjustment of sewing machines is an operation which requires great care. If a machine is acting badly, an intelligent study of its condition is absolutely necessary before a move to correct it can be made. Then, and not until then, can a remedy be applied with any hope of success.

General Consideration. So much has been done with sewing machines, and their various applications and forms of construction are so different, that it is hardly possible to group them, nor is it necessary. In nearly all the main functions are identical in principal, and before we take up each one separately, it is well to consider them generally.

Nearly all sewing machines have the combination of a *needle*; a throat or cloth plate, through which the needle passes after piercing the goods, a needle thread loop-laking device, and some form of feed. The needle must descend, or pass its point by the looper's point far enough and quickly enough to act in time for the looper to take the needle's thread, as soon as the needle's upward movement forms a loop, and the feed must do its work while the needle is out of the goods.

In feeding an ordinary piece of material on a plain machine, it can be generally stated that the feed must move laterally to carry the goods as much as is possible while it is above the plate, that is, have it appear above the plate as soon as possible after the needle has left the work, so as to have nearly all of its work done before it has to descend again, thereby getting the greatest amount of effective motion

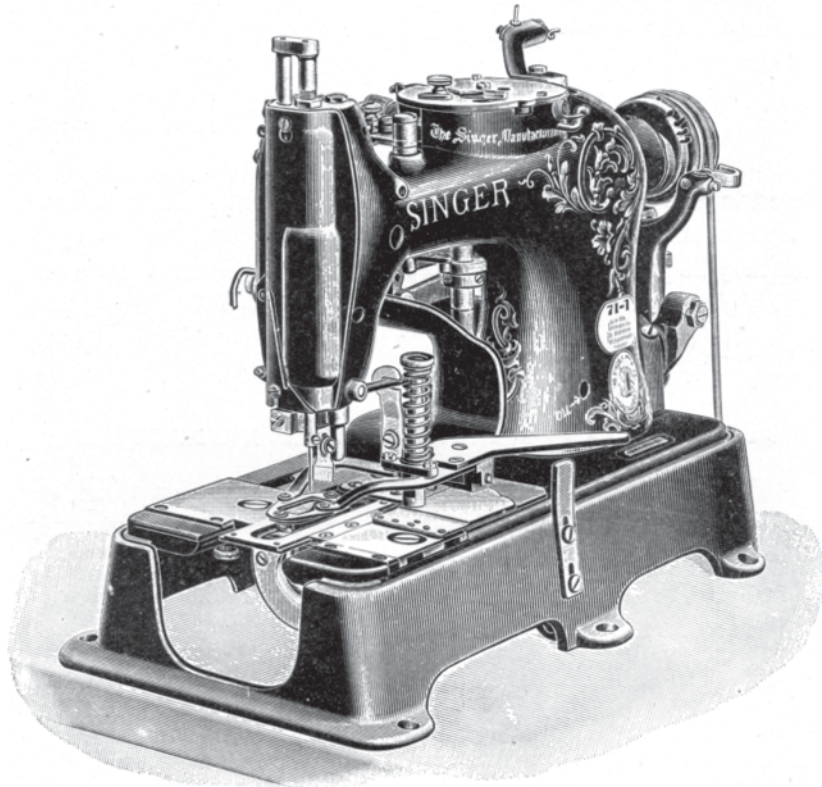

Fig. 9. Singer Button Hole Machine.

with the least amount of actual motion; for the four motion feed actuated by eccentrics (the easiest device known for high speed) cannot be made to take the ideal path, but takes the form of an ellipse. The ideal path would be a parallelogram. This could be obtained by having the raising motion take place before any lateral motion above the plate, and the drop motion before the return below, but it is not suitable for high speed, because the sources of motion would

need to be intermittent, one waiting for the other, and obtainable only with some form of cams, which are hard in their action and lack effective means for taking up wear. Thread controlling devices, such as takeups, and, of course, tensions, are common to all machines; and no small part of the adjusters' art is needed to properly manipulate these inoffensive appearing but highly necessary parts of the general whole.

Plain Finishing Machines. The plainest form of sewing machines embraces the Willcox & Gibbs and Union Special types. They are one needle, single-thread, chain stitch machines in the high-speed class; and on work where this form of stitch is acceptable are very

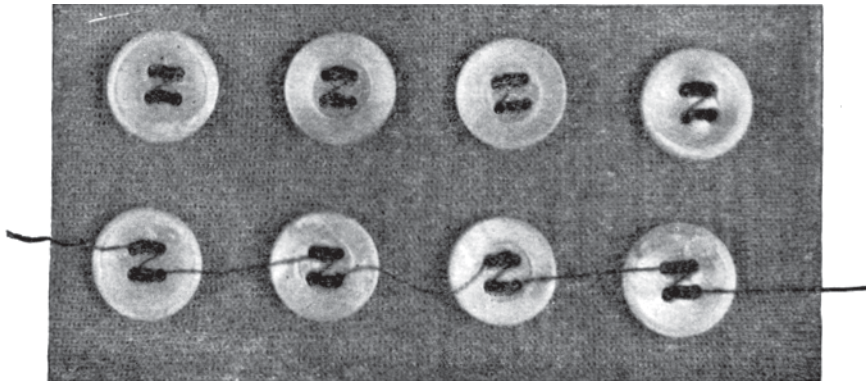

Fig. 10. Buttons Sewed on by Machine. The New Way (trimmed) and the Old Way (untrimmed).

economical, not only on the question of thread, but as to their ease of manipulation by the operator, and small number and simplicity of parts. When once in good working order they rarely need the attention of the adjuster, and when trouble occurs it is easily located.

The Needle. It is realized that the item of expense for sewing machine needles is large, and the practice of saving those which have been discarded and sorting the seemingly good ones out for use a second time, is perhaps an economy in some cases. The evils which an imperfect needle can cause are so many however, that it is of the greatest importance to make sure that this implement is not at fault.

An intimate and extensive knowledge of sewing machines and their habits has proved conclusively that it is a wise plan not to use

a needle a second time. If a machine is breaking more needles than it should, there must be some wrong condition of adjustment. This should be looked for and corrected.

The Looper. Having made sure of a good needle, the looper, or hook, must be examined and made perfectly smooth with crocus cloth. The point must be especially smooth and of the proper shape. If it has been broken or worn blunt, a careful grinding or stoning will restore it to the most favorable condition for taking a loop. If this process has shortened the length of the point materially, it may be necessary to change the spot on the shank so as to time the looper a trifle quicker.

In the Union Special type the looper may be quickened by lengthening its driving rod. As the point of a looper will allow of but little remaking this should be done with great care, for if too much is taken off it is useless. It may also be found that the thread has worn a groove, or crease, in the neck of the looper, where the loop, in the course of forming the stitch, comes to a rest. This may be the cause of breakage, and many times can be stoned out without changing its effective form.

In the Union Special type of machine the loop-retaining wire on the under-side of the throat plate must be looked at, and if rough, it also should be smoothed with crocus cloth. This part is adjusted so that the looper in its action travels very close to it. If it has by any chance become bent, so the looper rubs it, breakage of thread is sure to follow, either by being pinched off between the two parts, or by their roughness from the too close contact.

Before the machine is ready for a test, look over all the eyelets or guiding holes through which the thread passes. These must be smooth and round, that is, they should not have sharp corners over which the thread, in passing or being drawn up, will be compelled to take a sharp angle. If a groove or crease has worn in any of these, a new, smooth one is necessary. If a machine breaks the thread in the chain, the trouble is most likely with the feed, or presser-foot, perhaps both. The bottom of the presser foot must be smooth and have a bearing from end to end on the feed points. It should also rest its whole length on the throat plate when the feed is down. The needle hole and plate must also be examined for rough places.

The Feed. A feed that is new and excessively sharp, or one that has been worn dull, may cause a breaking of the thread. In the latter instance, the chain will not be fed away from the stitch-forming position positively enough. If a feed is too sharp, we have the emery and crocus cloth remedy. If dull, it can be annealed and the teeth refiled to their proper shape. Many times the sharp burrs or edges of feed points may be rubbed off with the wire side of a file card.

Skipping the Loop. The causes for skipping (or missing) stitches generally lie in the needle and looper. If this is the trouble, first make sure that the machine is threaded properly. Then see that the needle in raising throws out its loop favorably for the looper point to enter. If the loop is not large enough, try the needle a little lower still, say one-sixteenth of an inch. If not enough, then try it a little lower still. It is not best to have the eye of the needle over one-eighth of an inch below the under-side of the looper point when the needle is at its lowest position, and this may be considered the most favorable condition in nearly all cases. The exceptions might be when unusually hard or soft material is being sewed; and if, after trial, a lower position of the needle seems better, it will probably be necessary to make the time of the looper a little slower, thereby allowing the lowered needle time to rise and open out its loop before the looper point gets to it.

If the loop does not open out squarely before the looper point, the needle may be turned in its holder, or if it is spotted in the needle bar, the bar may be turned in the required direction to make the loop open favorably.

Loopers having short, slim points should be set so as to pass by the needle very closely, but not touch it, for, as a rule, the needles in such machines throw a comparatively small loop. In machines which carry a broad, longer looper, it will be found that the needle's eye is driven farther below the looper point, and has more of an upward movement before the looper point gets to it than is the case with the other. The vibratory type of looper may be set quite close to the needle on its forward, or loop-entering stroke, and as close to the needle on the return, or backward, stroke as is possible and touch it. These adjustments of the looper in relation to the loop retainer are quite vital points, and it is essential to have them correct before much else is done.

Skipping of stitches and thread-breaking can often be traced to poorly working tensions. The thread friction discs must always be free to move on the post and be clear of lint. If the thread has worn creases in the faces of the discs, they will not control the thread evenly. The spring also must be of the proper strength, yet perfectly flexible. If, having exhausted our list of remedies, the thread still persists in breaking, it is but fair that the quality of the thread be considered, for a small proportion of the thread which is made will not run on any machine, and it becomes a useless expenditure of time to try to make it do so.

High Speed. The matter of speed also is to be considered. Beyond a certain limit in every machine, excessive speed is actually more detrimental to a manufacturer's interests than too little, for once let a machine become racked and worn from this cause, its usefulness is over, and repeated overhauls become more and more necessary. In response to the user's standing request for high-speed machines, the designer's work is constantly carried on with this as one of the important ends in view, and no doubt time will produce machines capable of 4,000 and even 5,000 revolutions per minute.

Two Thread Finishing Machines. In taking up for consideration those sewing machines which use two threads in making their stitch, we enter a more interesting and instructive department of the whole sewing machine art and applications, and it is especially interesting when considered in connection with the manufacture of knit goods, for the very peculiar nature of this fabric at once prohibits the use of a stitch that might be perfectly satisfactory on goods of a firm texture. We may know this from the fact that thousands of machines which make the familiar two-thread, so-called lock stitch, with a shuttle and bobbin, are employed exclusively in making up our heavier outer garments, and also underwear, which is made from muslin and linen. These fabrics all are of a firm and non-elastic nature, so there need be no different element required in the sewing stitch which enters so largely into their construction, and consequently the lock stitch suffices, or rather we may say, it is necessary and therefore satisfactory.

Elasticity in the Seam. When our modern knitted fabric, with its beautiful and distinctive feature—elasticity—was invented, the question of garment making from it on sewing machines became a

vital and puzzling one, and especially was this the fact in the matter of seaming or joining the parts together, for if the old lock stitch was introduced for this purpose the non-elastic nature of it at once destroyed the very feature that brought this fabric into existence. From the very first, this stitch seems never to have been considered except in one or two impractical ways, and the only other recourse was to some form of chain stitch, and up to date but three forms of it have ever been used.

First, and for many years, it was the single-thread chain stitch with which all seaming, as well as finishing, was done, and we may take it for granted that this seam met all early requirements, but as the fabric was improved in texture, quality and finish, each succeeding year, the

single-thread chain stitch became deficient in many respects, and was finally supplanted by the two-thread chain, or double-locked stitch. This stitch was first made by what we knew as the Grover & Baker machine, and was a long step in advance of the single-thread chain stitch, because the second or additional thread not only doubled the seam's strength, but the manner in which the two threads were looped or interlaced with each other, produced a greater degree of elasticity—two elements which we know are of vital importance.

THE LOCK STITCH, DOUBLE CHAIN STITCH AND "OVERLOCK" STITCH

Sewing machines which use two threads in making their stitch may be grouped in three classes—the *lock stitch*, the *double chain stitch*, and what is known as the *overlock stitch*.

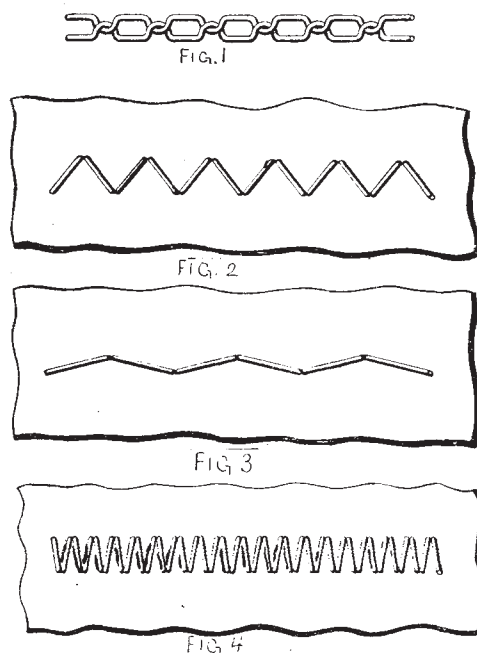

Fig. 10. Diagrams of the Lock Stitch.

Lock Stitch. The first, or lock-stitch, shown in Fig. 11, is the oldest form of the three. It is not used in the actual making of a garment from knit goods to any great extent, owing to its lack of elasticity, that is, it will not yield when the goods are stretched without breaking apart. This, of course, precludes its use for such a purpose. It can be, and is used in button-hole, button-sewing, over-seaming and cat-stitching machines, and in these operations it is

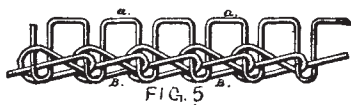

Fig. 12. Double Thread Chain Stitch.

perfectly satisfactory. In button-holing and button-sewing the stitches are confined to particular places on the garment and are not continuous as in a seam, so the element of elasticity is not required.

In over-seaming and cat-stitching, however, this stitch must be elastic, and as it is used in these operations it is so from the fact that the machines are constructed so as to lay the threads on the two surfaces of the material in a succession of diagonal stitches, as illustrated in Figs. 2 and 4, and when the fabric is stretched these diagonal stitches change their position to make an approximately straight line, something like Fig. 3 in appearance.

Different degrees of elasticity may be obtained by adjusting the machine to sew a varying number of stitches in a given distance. For instance, a seam having twelve stitches to one inch, will be much more elastic than one having four stitches in the same distance. There is no way by which this stitch can practically be made to produce an elastic straight-away seam, so if this is desired a lock-stitch cannot be considered.

Double Chain Stitch. The second, or double-chain stitch, is much more elastic than the lock-stitch, and is, therefore, peculiarly adapted for use in making garments from knit goods or any material of that nature. It is elastic for the reason that a surplus length of thread is introduced into each stitch, both in the knot or tie of the two threads together, and as it is laid on the surface of the material between the successive needle punctures.

The excess of needle thread is obtained from the fact that the tie or connection of this thread with the under or looper thread is always made on the lower surface of the work, so, instead of lying in a comparatively straight line, as it does in a lock stitch, it must pass

through the material to its tying position with the under thread, and then back again to the upper surface at each puncture of the needle. The position of this thread as it lies in the stitch is shown at A, Fig. 12.

A surplus of under thread is obtained in this stitch from a process of weaving or looping from stitch to stitch, which gives it a total of three times the length of the stitch itself; that is, there are three strands of thread laid on the under-surface from one lock to another. A close examination of a seam of this character will show the course of this thread quite plainly. It is illustrated at B in Fig. 12. In this manner both of the threads are given a greater length than the seam itself, and produce the necessary amount of elasticity. Of course, all of this elastic element may be eliminated from the stitch by excessively tight tensions, and it therefore follows that more or less may be obtained as required from the same agency.

“Overlock” Stitch.

The “overlock” stitch is the most elastic of all, and its distinctive feature is that it is, in addition to this, a very efficient covering or wrapping stitch. This makes it valuable

for edge-finishing, or selvedging, as well as for seaming, and when used for seaming the result is a beautifully-finished, even and perfectly elastic joint of the two parts of the garment, the edges of which are neatly covered and protected from wear. The elasticity of this stitch is obtained by laying so much of its thread, both upper and under, across the line of the seam.

Another advantage which the double chain and the overlock stitches have over the lock stitch is that the thread may be used directly from large spools or cones, for unlike the lock stitch, the spool-end of the looper or under thread is never passed through the needle loop but the two threads are locked or laced together from stitch to stitch, similar to a knitting stitch or crocheting. This does away with the necessity of bobbins for the under-thread, on which

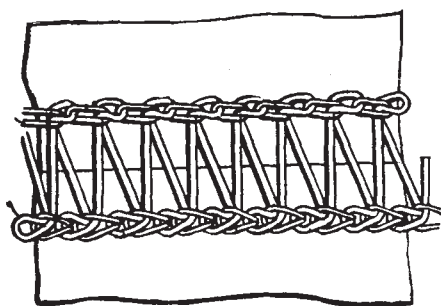

Fig. 13. Diagram of Covering Stitch.

the number of yards which may be wound is always limited, owing to the fact that the whole functional group, thread, bobbin, and bobbin-case, must be passed entirely through the needle thread loop for each stitch.

In the chain and overlock stitches only a very little more thread is drawn from the needle than is actually required to make the stitch when it is finally set in position, so that no great unused surplus must

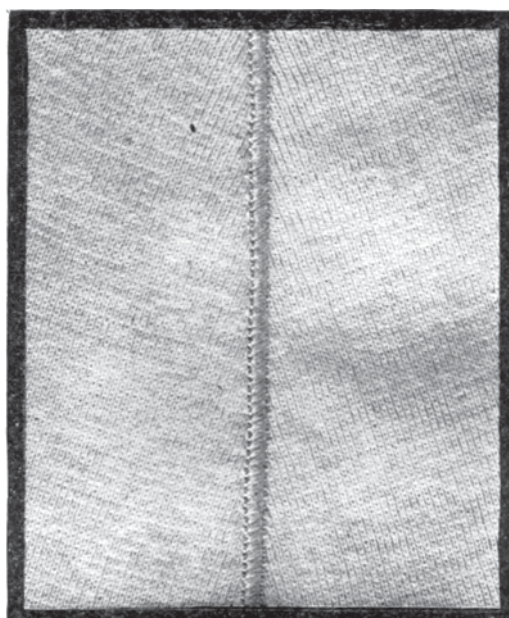

Fig. 14. "Overlock" Seam for Sleeves.

needs be taken back through the eye of the needle by the moving eyelets. For this reason, the thread is not served back and forth so much, and thereby frayed or weakened before finally laid in the stitch.

In referring to the accompanying diagrams it must be borne in mind that they are greatly enlarged, and the positions of the several threads are considerably distorted in order to show more plainly their relation to one another. In actual practice a machine with properly adjusted tensions and correctly operating stitch-forming implements will produce a perfectly smooth and even stitch which can be stronger than the fabric itself, given the proper quality of thread.

Tension. The matter of tensions is a very important one in all sewing machines, and we may say that it becomes more so as the speed

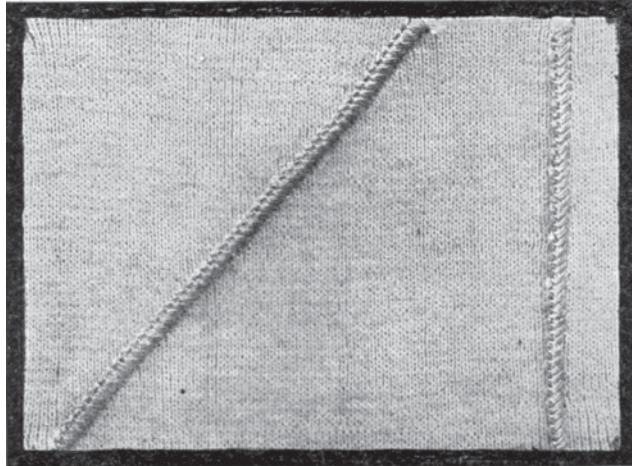

Fig. 15. "Overlock" Seam for Sides and Gussets.

factor is raised in each successive "new model" which is brought out,

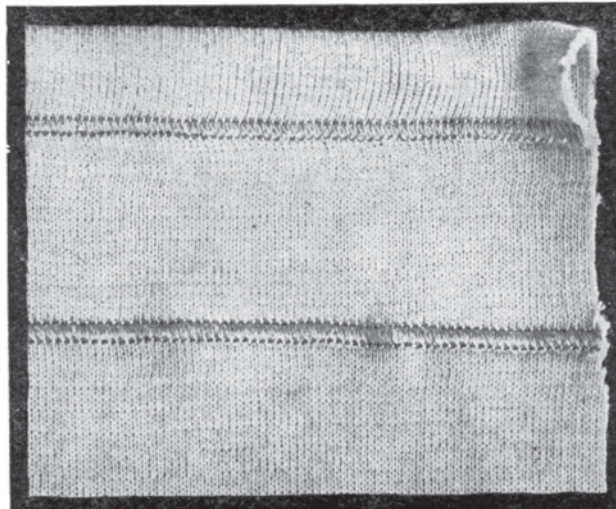

Fig. 16. "Overlock" Seam for Shoulders and "Overlock" Concealed Stitch Hem for Shirts and Cuffs.

for it must be borne in mind that the same functions exist and must be reckoned with in every kind of stitch, whether it is made at a low

or high rate of speed. One of these functions is that a never-varying quantity of thread must be measured off for final treatment by the stitch-forming implements, *i.e.*, the needle, looper, etc., in every individual stitch, and the problem is to produce an even stitch with the

greatest amount of precision, and without applying any unnecessary friction on the several threads.

Trimming the Seam. Another element of great interest to us in the development of a sewed seam on this peculiar fabric is the inception and subsequent stages of improvement of the trimming devices which now are used in connection with the stitching mechanism.

Previous to 1880 the hand-sheared seam prevailed, but the inventive and ever alert minds of the sewing machine makers quickly saw an opportunity, and at once began to consider the feasibility of combining with the sewing mechanism an efficient trimming device which would perform its office simultaneously with the making of the seam, and thereby eliminate the slow, tedious operation of shearing the projecting surplus by hand.



Fig. 17. "Overlock" Over-Edge for Shirts and Cuffs and "Overlock" Tailor-Made Seam for Shoulders and Gussets.

The first trimmer seems to have appeared about 1880, and was in the form of a circular disc with a portion of the disc left blank in order that the feed might operate freely. Other devices of minor importance followed at intervals, until the device which acted on the shear principle appeared. This

was practical and efficient, and was in use extensively for some years. Then came the trimmer, which operated with the abrasive process, and finally a machine was brought out which embraced in one complete whole the three elementary functions of sewing, trimming, and covering the seam at one time.

This brings us to the present day, and from all the various inventions for the purpose of trimming knit goods which we know of, but two of them have survived and are used to any great extent. These are the *abrasive trimmer*, which is used in conjunction with a machine making the two-thread, double-locked chain stitch we have already mentioned, and the *shear trimmer*, which is incorporated in the machine combining the three covered stitch functions. These two trimming devices have stood the test and proved to be very important agents in the process of making the two types of our present finely-developed, covered, elastic seam on knit goods.

The Union Special Dewees Trimmer. The Union Special seaming and trimming machine (shown in Fig. 6) was the result of a combination of the Union bag sewing machine and the Dewees trimmer, which was effected about 1885. The sewing stitch is the two-thread, double-locked chain mentioned above, and the trimmer is of the abrasive type.

This machine has stood the test of years as to strength, durability, speed, and general all-round efficiency. The trimming device is an original, unique, and effective one, requiring no sharpening of knives, is durable, can be operated at a high rate of speed, cuts a clean edge, and the amount of fabric beyond the seam can be regulated to suit any material. It will perform its work satisfactorily for days, with practically no attention whatever other than the ordinary oiling of its parts.

In the final development of the seam, after it has been seamed and trimmed, the garment is submitted to another operation, which employs one of the best designed Union Special machines. This is a side wheel cylinder, two-needle, three-thread machine, especially adapted to cover the trimmed seams on knitted fabrics. The cylinder is small and permits of covering the seam of a very small sleeve or leg. Two parallel rows of stitches appear on the upper surface of the material, (or outer side of garment) while on the lower surface of the material, (or inner side of garment) the rows of stitches are inter-

locked by a thread which entirely covers and draws down flat that portion of the fabric beyond the seam. This adds strength to the seams to a great degree, besides producing a very sightly and comfortable result.

The seam which is made on this system is one of the best which has ever been devised. It has great strength, each stitch being fastened independently as well as in combination, so that it cannot rip, and is very elastic. It is flat and smooth on both faces of the garment, thereby ensuring the greatest comfort to the wearer.

In adjusting the trimmer on the Union Special both upper and lower toggles must first be ground on a true circle with the center of each one, which is easily done on the small grinder furnished with this machine. The upper toggle should then be dressed to a small round on its circular edge, so that its contact with the lower toggle will be but a very narrow edge having no sharp corners. The lower toggle must be left straight or flat, across its circular edge to provide a smooth surface for its mate.

To adjust toggles, fasten the lower toggle in the toggle frame by its fulcrum and clamp screws, and see that it is at the proper height in relation to the feed, means for this purpose being provided by a wedge with thread and nut at one end which lie in the toggle frame beneath the fulcrum block. The height of this toggle should be with its circular edge about half-way between top of throat-plate and top of feed-dcg when the latter is at its highest position; then fasten upper toggle in place and move it down to the lower one by means of its wedge, so that they touch each other. It may be found on testing them with a piece of cloth that they will need a trifle closer adjustment, but care must be taken that they do not press against each other any harder than is necessary to trim the cloth cleanly, for too much pressure will produce unnecessary wear and is liable to break the edges of the toggles.

To adjust for width of fabric beyond the seam, move the whole toggle frame to or from the needle or line of stitching, first loosening the screws which hold it to bed of machine and needle bar head. When the desired width is obtained be sure that all screws are tight.

To adjust needle with looper, when the needle bar is at its lowest point, and the looper is at its extreme backward throw, the point of the looper should be nine thirty-seconds of an inch from the needle,

and in its forward throw should pass the back side of needle as closely as possible and not touch it, and in its backward throw the needle should just clear the back side of looper. The adjustment of this rocking motion of looper is by means of set screws in the looper rock shaft fork which secures it to the rock shaft. The lateral adjustment of the looper is by the connecting rod from lower arm of needle bar lever to the looper holder. After loosening the check nuts at each end of this rod, which has a right and left hand thread at the ends, a slight turn in one direction or the other will move the looper to or from the needle. The needle should be adjusted with the deep groove towards the operator, and of such a height that the eye will be about three thirty-seconds of an inch below the looper when the latter's point is just back of the needle. In most cases this adjustment of needle and looper will ensure the most favorable conditions for taking the loops of thread, but some unusual conditions of thread or fabric may require a slight modification, and this must then become a matter of the adjuster's own judgment.

Tensions. In this machine the lower tension should be looser than the upper, but the proper adjustment of either one will be found to vary with the quality of fabric. That of a hard or non-elastic nature requires, and will stand, a tight tension, varying with the strength of the thread. In sewing on knit goods of an elastic nature, the object is, of course, to produce a seam which will be strong and at the same time just as elastic as the material itself, and it is obvious that the latter result cannot be obtained with too tight a tension. A good test to determine the proper position of the tensions is to examine the seams after sewing: if the seam gaps or opens on pulling the two pieces of cloth apart then tension is not tight enough, and if on pulling it lengthwise of the seam the threads break the tension is not loose enough.

Take-up. This part operates to take up the slack of, and cast off at the proper time, the lower or looper thread. The adjustment of the cast-off function will be found by raising or lowering the retaining wire, the points of which have their position in the central groove of take-up.

To Adjust Nipper Springs. These serve to hold the looper thread tighter than the tension discs will do at the time of setting the stitch; they should close and nip the thread just as the take-up comes

up between the thread eyelets and touches the thread; again, when the looper has reached the end of its backward throw and is ready to come back, the nipper string should be closed. If greater elasticity is desired, adjust the spring to nip a little later, by means of the adjusting screw in the lug directly underneath the free end of nipper spring. By raising or lowering this screw the nipper spring is made to nip the thread earlier or later, as desired. Both of these parts—take-up and

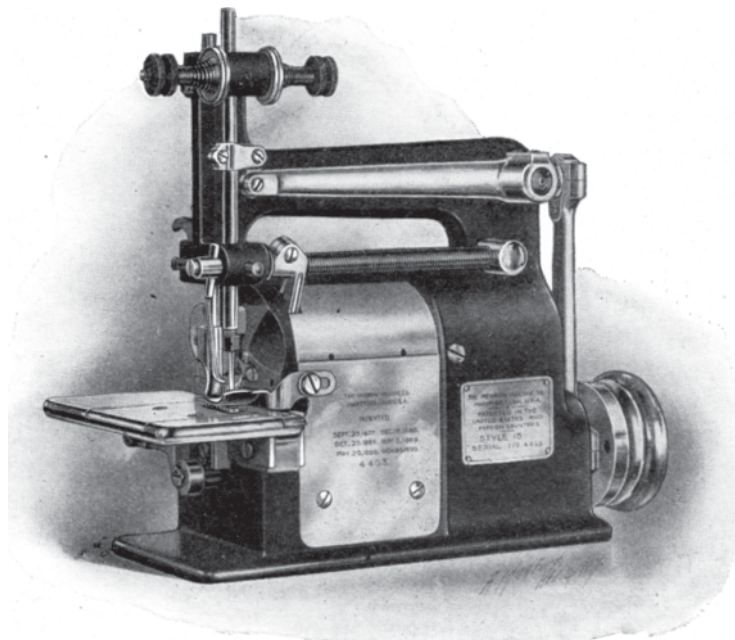

Fig. 18. Merrow Plain Crochet Machine.

nipper spring—are sensitive to a large degree, and should not be moved unless the adjuster is sure there is a reason for so doing.

The Willcox & Gibbs “Overlock” machine, (see Fig. 5) combines, in one complete whole, the necessary mechanism to produce in one operation a trimmed, joined, and covered seam, and makes the “Overlock” stitch. In appearance it is a radical departure from the long accepted type of sewing machine, chiefly owing to the absence of the familiar overhanging arm. This novel design is not unpleasing, however, and the machine is very strong and compact.

All the operating parts of the machine proper, are mounted on a single casting or frame, and this frame with its several mechanical functions is hinged to a plain box casting, which serves as a rigid base or support, and is also a receptacle for the oil which drips from the bearings, thus preventing an unsightly oil-soaked work table. This arrangement of the various parts makes them easily accessible, and all parts can be reached either from the top of the frame or from the under side, which is presented to view when the frame is raised up and backwards on its hinges.

Adjusting. On the subject of adjusting, in relation to this machine, there seems to be a scarcity of matter which may be said or written, for in its design several functions which in the ordinary sewing machine have a latitude of adjustment are here found to be positive and permit of no change whatever. About the only possible adjustments are those for the length of feed, or stitch, the width or bite of seam, or over-edge, and the lower trimmer blade; also to a limited extent the tensions. The take-up and pull-off functions are positive and admit of no change.

Tension. In all sewing machines there is probably no one feature so extremely sensitive, or which, if changed ever so slightly, produces poor results so quickly as the tensions. When trouble is traced to the tensions, the first act should be to draw the discs apart and blow out the lint so that the discs may come closely together and not be hindered, by bunches of lint, from pinching the threads and doing their full duty. Other than this, little trouble may be experienced with the tension mechanism.

With the "Overlock" machine all of the tension nuts are restricted in their movement to less than one full turn, so it is evident that no very great error can result from poor adjustment within this limit. Furthermore, as the pull-off and take-up functions are constructed, any degree of tension that may be necessary to meet the different requirements of the stitch on light to heavy fabrics are found within this comparatively small range of tension movement.

Width of Seam. The adjustment for width of trimming or bite has been made semi-automatic; that is, it is operative within certain predetermined limits at the will of the operator, and while the machine is in motion, This is accomplished in a very convenient manner by means of a treadle connection to the trimmer adjusting arm, which

when actuated serves to alter the position of the trimming parts in relation to the line of needle punctures.

This feature of the machine enables an operator to complete a garment with seams which vary in strength as required in different parts of the fabric. For example, a seam which is made along the side of a sleeve or drawer leg will be stronger than one made across the top or shoulder of a shirt, providing no change is made in the machine. In the first instance, the stitching is with the wale, or lengthwise of the fabric, where there is no tendency of the knitting

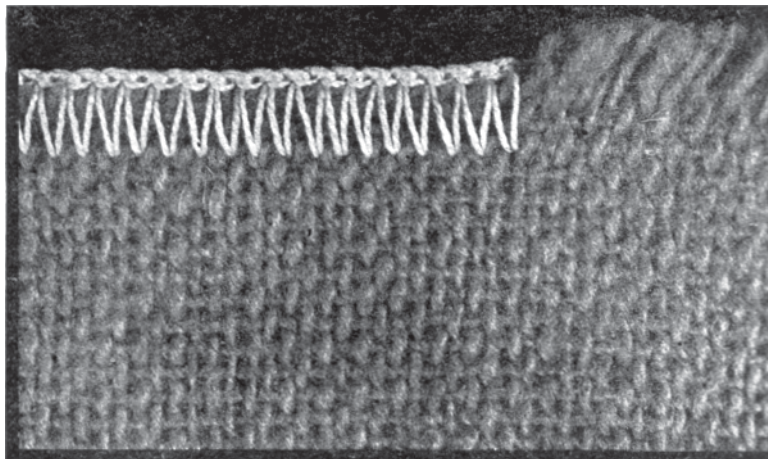

Fig. 19. Two-Thread Crochet Finish on Very Rough Edge.

stitches to ravel out, so that a minimum width of seam or trim can be employed.

In seaming across the top or shoulder, and around arm-holes or gussets, the stitching is laid either squarely or diagonally across the ends of the wales, where the knitting loops are exposed and extremely liable to unravel if not properly secured; therefore a wider seam is necessary. When it is desired to use this width-changing feature of the machine a thumb-pin is inserted in one of a series of holes in the trimmer-adjusting arm, back of a stationary stop, and when it is against the stop this pin is a limit for the narrow seam. Another thumb-pin placed in a hole in front of the stop, as far away as is necessary, to give the required change, will be a limit for a wide seam.

In operation this trimmer adjusting arm is held normally in position for a narrow seam by a spring, and when the treadle is depressed the trimming parts are moved to the position for a wide seam.

Setting the Trimmer. In setting the trimmer blades for seaming, the cutting edge of the lower blade should be adjusted even with the top of the throat-plate, or needle-hole piece. For concealed stitch hemming this blade must be a trifle higher, and for both purposes the cutting edge of the upper blade must pass by that of the lower one a sufficient distance to ensure clean cutting of the fabric. The position of the upper blade is determined by a stop, so there is small chance for error. It is very essential that the trimming blades should be



Fig. 20. Single Thread Crochet Finish, Hemming Edge.

kept sharp, for if they are allowed to become dull no end of annoyance and bad work will ensue.

Sharpening the Cutters. That the blades may be ground accurately there is furnished with each plant of "Overlock" machines a trimmer blade grinder. On the slide of this little machine a set of grooves has been milled to fit the respective upper and lower trimmer blades, and when in position the blades are held and presented to the emery wheel so as to give their cutting faces the proper angles. In shaping the ends of the blades be careful to have them fit the templets on the slide of blade grinder.

MERROW KNIT GOODS FINISHING MACHINES

The Merrow Plain Crochet Machines, a type of which is illustrated in Fig. 18, are made in several styles each adapted to produce a crochet finish upon the edges of various fabrics. Some of the finishes from the different styles of Plain Crochet Machines are illustrated in Figs. 19 and 20.

The Merrow Scallop or Shell Stitch Machine illustrated in Fig. 21 produces the two thread shell stitch finish about half an inch deep.

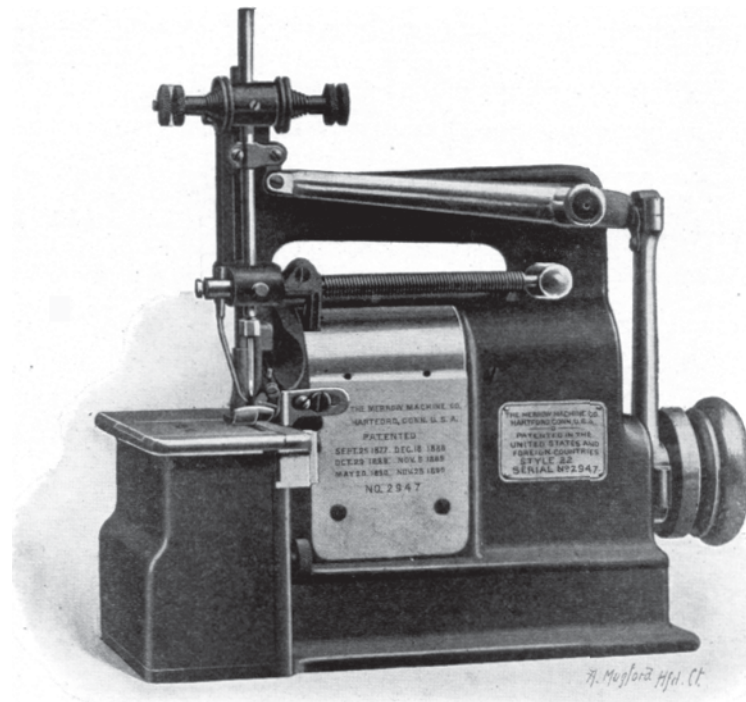

Fig. 21. Merrow Scallop or Shell Stitch Machine.

This finish is beautiful and substantial and is used upon a great variety of fabrics such as heavy knit goods, eiderdown garments, etc.

Fig. 22 represents the shell stitch finish, full size, as made by the machine on knit goods. This machine is used to produce shells of two, three or four stitches each as a foundation finish, upon the edge of which a smaller shell finish is later made by another style of shell machine.

The smaller shell finish made by a variety of this machine, upon the edge of knit goods, is used separately for binding the edges of

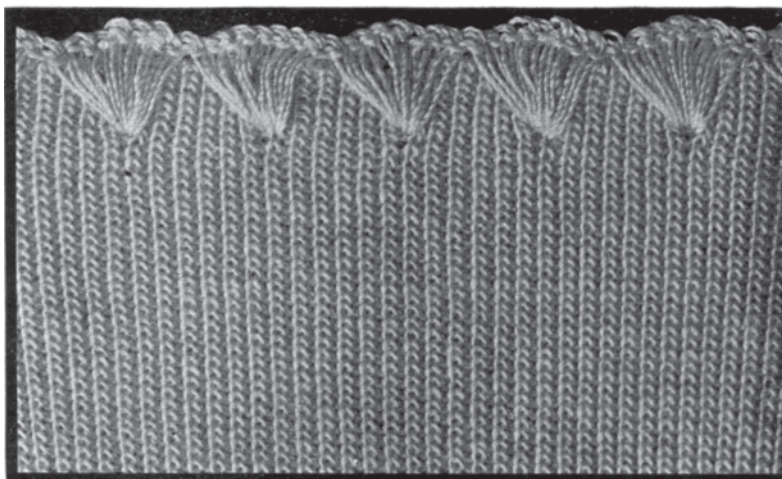

Fig. 22. Shell Stitch Finish, Full Size

light-weight goods. On many classes of knit underwear two or more

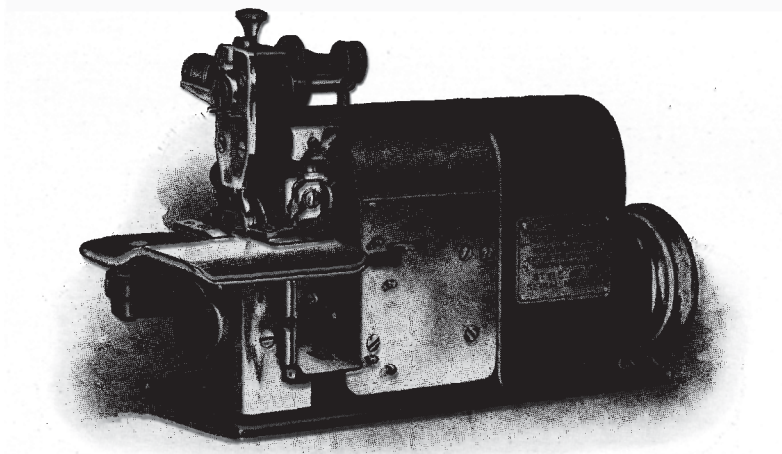

Fig. 23. Merrow Two-Thread Trimming and Over-Seaming Machine.

courses of this finish can be used to great advantage. Braid, tape or ribbon is sometimes drawn under the foundation finish.

The Merrow Two Thread Trimming and Overseaming Machine, illustrated in Fig. 23, is primarily designed for overseaming two or more pieces of fabric together, and is provided with trimming devices for cutting off the edges of the goods simultaneously, and in advance of the overseaming operation, when overseaming, and for trimming off the surplus material at the edge of the goods, when edging, and is also provided with devices for controlling the edge of the fabric in advance of the edging operation, and to facilitate the finishing of cuffs and other tubular goods. A variety of this machine produces a three thread overseam stitch which is especially desirable as an edge finish.

Another style of machine is for producing the blind stitch hem on the bottoms of shirts, etc., such as fleece-lined goods; while still another is especially adapted for producing the blind stitch hem upon the tops of stockings.

PLAIN FINISHING MACHINES

Operating and Adjusting. In the processes of trimming or finishing vests, shirts and drawers, the sewing machines used for these purposes, as well as those for the making or seaming operations, have now been brought to a high state of perfection, and the results obtained are very artistic and pleasing. While the obstacles to be overcome in this branch of the work are not so numerous or as difficult as in seaming, they are oftentimes troublesome, and the final appearance of the garment depends largely on the manner in which these machines are kept up to a proper performance of their work.

In a general way, a few points in these finishing operations may be mentioned which seem to need particular attention. In the matter of feeding, for instance, if the material comes out having a puckered appearance, either in stitching on the bands or facings, but especially in binding, a truly finished effect is absent, and the cause of such work may often be traced to a poorly-working feed. Again, a machine may be making an excessively coarse stitch, which on fine garments, especially, is very unsightly. This, of course, is easily remedied, and after the proper number of stitches to an inch is once decided upon, care should be taken to see that this standard is adhered to.

The size of the needle also plays a part in the general effect, for a needle which is larger than the thread calls for, leaves holes in the

comparatively hard facing or band fabric which the thread does not fill up properly, and oftentimes gives the impression that the holes have been made for rivets, with the rivets left out.

Another point which is more of an individual than general nature, depending largely on the character of stitch made by the machine in use, is the laying of the stitch on the under side of the fabric, or inside of the garment.

In every machine, whether it makes the lock, single chain or double chain stitch, there is a specific method of drawing up the thread on the under side, and perhaps this point in the adjustment of a machine may be called the most important of all, for the design of the whole machine is dependent and made subordinate to the one feature of making the stitch, and surely a slightly appearance on the reverse side is just as important as it is to have the upper side correct. Then, also, if either of the threads is not drawn up properly a greater quantity of thread than necessary is being used.

In the lock-stitch, which lays but a single thread on both sides, it is, of course, possible to obtain a like effect on the top and bottom, and that very easily, through the medium of tensions, provided all other functions of the machine are in normal condition. Owing to the old drawback, the winding of bobbins, always present in a machine of this kind, and their comparative slow speed, lock-stitch or shuttle machines are seldom used in finishing operations. It cannot be denied, however, that this stitch is strong enough for the purpose, not liable to ravel out, and presents a neat appearance on both sides of the fabric. Several of the concerns that build this class of machines have expended large amounts of money and inventive energy to overcome their inherent defects, and with considerable success. The Willcox & Gibbs, Standard, Wheeler & Wilson, and Singer companies have each recently brought out high-speed machines of this type, and in their design and construction several novel features have been introduced.

The Willcox & Gibbs Lock Stitch Machine. (Fig. 24.) The machine built by the Willcox & Gibbs Company is built on the well-known Willcox & Gibbs system, of the finest of material and workmanship, and is a long step forward in lock-stitch sewing mechanism, embodying high speed, perfection of stitch, perfect tension control, yet simple and durable, and easily adapted to handle the most deli-

cate of fabrics, as well as the heaviest. The other machines of the type referred to also have points of excellence.

The type of machine used almost universally for finishing operations on knitted underwear is the one which makes some form of a chain stitch. The reason for its use is that the threads may be led to the machine and used directly from large cones or spools, thus avoiding the constant stopping of the machine to replace the empty bobbins with newly filled ones, as is the case with shuttle or lock-stitch machines. The item of interruption in a day's work is not inconsiderable.

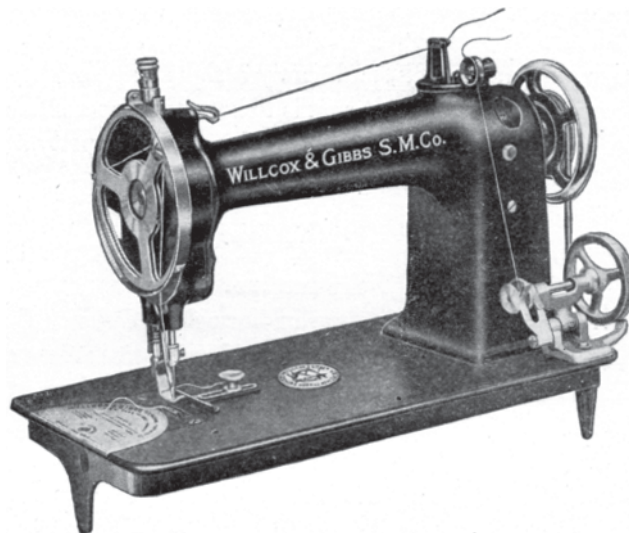

Fig. 24. Willcox & Gibbs Lock Stitch Machine.

The mechanical design and construction of the chain-stitch type, in the matter of continuous rotary motions, and strength and simplicity of parts, is more favorable to high speed than any lock-stitch type. For these reasons the chain-stitch machines are the most economical, both from the point of production, and care and expense of repairs. This stitch is also of advantage where an ornamental effect is desired, as on vest and drawer facings, or on the edge of binding.

The Union Special Finisher. The finishing machine designed and built by the Union Special Machine Company has found great favor for the latter class of work. They make either the two-thread

chain or "safe elastic stitch," or the single-thread chain stitch, and if so desired, the two types may be combined in one machine, for the basic functions of both are identical and the few necessary changes can be easily and quickly made. This point is of undoubted advantage in the case of a small mill where the number of machines is limited, or when there is not enough work to warrant the investment for separate machines for each individual operation. In a large mill, however, it is much more economical to make this provision, for by so doing a machine when once adjusted to a nicety for its particular

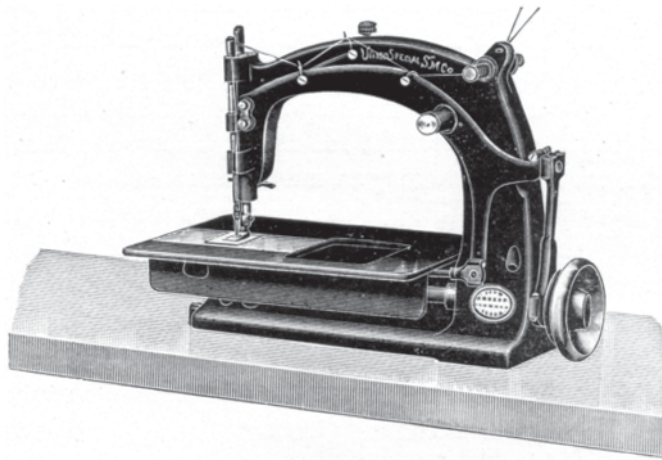

Fig. 25. Union Special Plain Finishing Machine.

work may be left so, and not require any further care from the adjuster.

One style of Union Special machine has been designed for finishing knit drawers. It is built on lines similar to those just noted, and has the same general characteristics. In stitching on an inside band, where a silk finish is desired, this machine makes a beautiful, ornamental stitch, greatly adding to the appearance of the garment. A large saving of silk is effected by using cotton thread in the needle, and silk, or a fitting substitute, in the looper, care being taken to adjust the tensions so that the upper, or cotton thread, will not show on the under side.

The Willcox & Gibbs Finisher. The Willcox & Gibbs chain-stitch finishing machines are largely used for binding, being especially adapted for the purpose. These machines are furnished with the automatic tension, or with the ordinary friction discs, a tight wheel, or the two tight and loose pulleys for driving, and a feed surface with one or two lines of teeth. They may also be had with the registering or measuring tension. The object of the latter is to measure off and deliver to the looper the exact amount of thread required for each stitch, to uniformly draw up each stitch to any desired degree of tightness, and produce sewing that is perfectly smooth and even without any care on the part of the operator. It can be readily adjusted, and the resulting seam will be of unvarying strength and elasticity. The thread cutter attached to this machine is worthy of note, because it prevents the characteristic tendency of this type of stitch to ravel. By its use the thread is cut at the end of every seam when the work is taken from the machine, leaving an end of thread about three-eighths of an inch on the under side and drawn through the last loop, which "fastens off" the seam and prevents its ravelling. It can be made doubly secure by pulling this end, which is through the last loop, toward the sewing. The cutting is accomplished by a slight forward and backward movement of the hand wheel by the operator when the needle is brought to a position to allow the work to be taken out.

The Singer Manufacturing Company build a single-thread, chain-stitch machine, having a similar method of forming the stitch, which has considerable room under the arm. It is similar in design to the machines of this type which have been described, differing in points of construction. The needle bar is driven by an upper rock shaft. This shaft lies back of the head-supporting arm, and its connection to the needle bar is completely covered in the head. Thus, no moving parts are here visible, and therefore are not liable to throw oil. The feed mechanism has positive movements, and the length of stitch is adjusted without the use of springs. This machine is furnished with the ordinary plain friction tension or an automatic device.

Adjustments and Repairs. All machines of the single-thread, chain-stitch type are capable of a limited variation in laying the stitch through the medium of their tensions. The thread may be drawn closely to the fabric, thus forming a close or tight seam, or it may be

left in an elastic chain as desired. A beautiful stitch, resembling braid may be produced by using coarse silk, which is effective as an ornamental finish on facings or bands. By manipulating the tensions in this manner, many pleasing results may be obtained with both the one-thread and the two-thread types of chain-stitch machines.

In making an ornamental edge on binding, it is customary to run the braid or binding through a machine directly from the roll, reeling it from a full roll on a pin in front of the machine to another one at the back. The operator who stitches this prepared binding to the garment will make the fold at the line of the ornamental stitching, thus presenting a silk purl on the edge.

All of the sewing machines which we have to deal with today have either spot screws or pins to confine the different parts in their proper functional relation with each other. This has been found to be absolutely necessary, and especially so with reference to high-speed machines; for even those built on the most scientific principles would become disarranged by a few turns at the rate of 2,500 or 3,000 revolutions a minute.

The location of these pins and spots on the shafts, studs, etc., is not determined until the most favorable relative positions of the several parts are fully established after many trials in the sewing-off or adjusting room; and when finally fixed upon these points of registration are exactly duplicated in every machine of the type in question by a set of accurate jigs and fixtures, many of them costing hundreds of dollars to design and build.

In timing the loopers of chain-stitch machines of the Willcox & Gibbs type, the eye of the needle should be about $\frac{1}{8}$ of an inch below the under side of the looper's hook, when the needle is at its lowest position. Then, as the needle starts upward and the looper point approaches it, these two implements should pass each other as closely as possible and not touch, with the needle's eye about one thirty-second of an inch below the under side of the looper's hook. This will ensure time enough for the needle to raise and throw out a good loop before the looper gets to it, and a good looper will then handle the thread during the succeeding stages of the stitch in a satisfactory manner.

In setting the needle, the long groove must be at the left, or away from the looper point, and its shank should rest against the bottom

of the hole in the needle bar. If the eye of the needle is then not at its proper height in relation to the looper, as described above, it can be adjusted by the eccentric ball at the driven end of the needle-bar lever. In some of these machines it is possible to turn the needle in the bar, or the bar itself, which is an advantage when it is desired to throw the loop to or from the looper's point, thereby favoring the latter a trifle in handling different qualities of thread. Generally, however, the loop should throw out squarely with the line of feed.

The looper is positioned in its rotary direction by a spot on its shank which receives a set screw in the shaft, and the only adjustment which is usually necessary for this implement is in its endwise position, to bring it to or from the needle. If it seems desirable to time the looper a trifle quicker or slower, this may be accomplished by changing the spot on its shank one way or the other with a fine file.

When the needle and looper in this type machine are in their proper relation to each other, it will be found that the tension, once adjusted, will need but very little variation. Care must be taken, however, that it is not so tight as to destroy the elasticity of the stitch's varying thicknesses of material or a change of stitch to fine or coarse, may require a slight alteration of the tension.

In timing the looper of the Union Special two-thread, chain-stitch machine, the eye of the needle, when in its lowest position, should be about three-sixteenths of an inch below the under side of the looper. The shank of the needle should rest against the bottom of the hole in the needle-bar, with the long groove in front or towards the operator, and securely fastened. If the eye is not at the proper height the bar can be raised or lowered in its driving connection. Care should be taken to use needles that are perfectly straight and have good points. The size of needle is determined by the thread used, a fine thread taking a small needle, and so on. Many times when a machine is working poorly, a larger size needle will handle the thread better and eliminate all the trouble.

The looper should be adjusted so that its point is one fourth of an inch from the needle when it is at its extreme throw to the right, and, in passing the needle on the back side, that the point will just clear the needle. This will ensure a good loop when the looper has advanced to meet it. When the looper makes its return throw to the

right, the needle must pass the back side of the looper with its point a little to the right of the looper's eye, in order to take and hold this looper-thread until the next needle-loop is secured by the looper, thereby locking or enchaining the previous stitch with the last one. In passing each other, the needle and looper should just clear on both strokes.

These adjustments of the needle and looper may be varied a little to meet varying qualities of thread or material, but for ordinary conditions they are correct. Enough tension should be used on both threads to produce an even stitch, but if an elastic stitch is required the under tension should be considerably lighter than the upper. If either one fails to control the thread properly it may be found that a bit of lint has collected between the discs, thus holding them away from an even contact with the thread.

When the under thread lies straight from the heel of the looper to the double-wire fork, and just before the approaching edges of the rotary take-up touch it, the nipper-spring should hold the thread fairly tight, for at this point in each revolution of the machine the required amount of under-thread for the stitch is determined. If it is desired to regulate this, it may be done by means of the set screw in the lug on the looper-rocker, the head of which rests against the free end of the under nipper-spring, and taking its motion from the looper-rocker, serves to open and close the two nipper-springs in contact with each other. As the take-up revolves it will carry the thread upward and back, so that the retaining wire will catch and hold it until the slightly lower part of the take-up is in a position to allow the cast-off to take place.

The duties which are required of a feed and presser-foot in this work are identical in all machines, so our treatment of these two functions will apply to both of the types under consideration.

The top of the feed must be level and the teeth fairly sharp, but with no "hooks" or "burrs" on them. If the feed points seem to be too sharp, or cling to the fabric, a good remedy is to hold them against a revolving wire brush, just enough to smooth the points and not dull them materially. The rise of the feed surface above that of the cloth plate will vary within certain limits, according to the weight and texture of the material to be sewed, but for general work this should be about 1-32 of an inch.

A *hinged presser-foot* is the best for nearly all classes of work, for it enables the seams of garments to pass between the feed and foot more surely, and will conform to the top of the feed in any position, thus ensuring a firm hold on the material from a minimum amount of tension on the presser-bar spring. In the operation of binding it will be found that the feed and presser-foot must be in good condition, and in correct relation to each other. The presser-foot must set squarely on the feed points, with no side motion, and have an even contact on the cloth plate when the feed has dropped for its return stroke. If the goods have a tendency to run off sideways, in feeding through, it will probably be found that some one or more of the feed or presser-foot conditions are not right.

General Adjustments. In the course of time, with all machines, it becomes necessary to give them something more than a somewhat superficial "setting in order," and a general overhauling is required. When one shows signs of excessive wear, a few new parts, and a general tightening up of joints and fits will restore the machine to a more efficient condition. An adjuster who watches his machine closely will detect the wearing points about them as they begin to appear, and by judicious attention here and there can postpone the time when a general overhauling will be necessary.

The parts of all machines worthy of mention are manufactured in duplicate, so that a new part will replace one that has worn out without any fitting. New parts may be ordered from a catalogue of parts pertaining to the machine in question.

Many of the wearing parts are provided with means for taking up this wear as it occurs, but in the case of shafts and needle-bars this is not so, and when these parts become badly worn the only remedy is to replace them with new ones a trifle larger, and ream the holes to fit. For this purpose the shafts and bars are made in two or three different sizes, one being three or four thousandths of an inch larger than the original, and a third the same amount larger than the second one, thus providing for several renewals.

The holes are enlarged by an expansion reamer, having a long pilot extending from both ends of the fluted cutting section. In using this tool care should be taken to ream the holes perfectly straight, and a very little at a time, in order to secure as good a fit as possible and keep the bearings in true alignment.

The Union Special Company has introduced a new method of mounting the needle-bar, which provides for a renewal of the worn-out bearings, as well as the bar, and also furnishes means to take up a limited amount of the wear before a renewal is absolutely necessary. In the construction of these bearings the two ears, or lugs, through which the needle-bar passes, are drilled and reamed out at the factory somewhat larger than the bar itself, and a thin shell, or bushing, is inserted, which is then the bearing. This bushing, and also the encircling lugs, are split on one side, and by means of clamping-screws in the latter, the bushings may be collapsed a sufficient amount to meet the reduced surface of the bar. In case of renewal, these bushings may be discarded and new ones inserted to fit an original-sized bar, or they may be retained and re-reamed for the next larger one, as in the older method. The great advantage of the new system seems to be the clamping feature, which allows the wear to be followed up as fast as it occurs.

MISCELLANEOUS MACHINES USED IN FINISHING KNITTED UNDERWEAR

There are various operations in the finishing of knitted underwear that are performed differently, and with different machines, according to the system or custom in force in the mills. Some mills use for binding what is called a purl edge binding, made in the mill by running plain binding of most any kind through a Union Special Single Needle Ornamental Machine, oftentimes called Binding Machine. This machine is built on the same lines as their drawer finisher with certain minor changes, and with attachments for holding and guiding so that the purl edge may be laid on in the middle of the binding as it passes through the machine. Oftentimes the machinist in the mill is ingenious enough to rig up an attachment for rolling up the binding as it comes from the machine.

One of these machines arranged in the above manner, will, after being started, make the purl edge on the whole roll of binding without attention of an operator until a new roll is to be started.

As drawer bands have to be stitched together, most mills have in their outfit a band stitcher. Any extra machine can be pressed into service for this purpose, though it is preferable to have a two-thread machine; it is often a W. & G. plain tension machine as anything else, and even sometimes an old line lock stitch machine.

A drawer strapping machine is important now, as many manufacturers are sewing on suspender straps in a durable manner with machines especially designed for that particular purpose. While straps have been sewed on with plain single, and double thread, chain, and lock stitch machines, it has always been apparent that a zigzag lock stitch was the most desirable. The "Standard" have a machine for such a purpose, the Union Button Sewing Machine Company and the "Singer" have a machine especially designed and adapted for sewing suspender straps on drawers and making stays and bars at required places in union suits and ladies' vests. It fastens the strap securely, rapidly and in a proper manner.

Zigzag machines have been used for several purposes after being adapted more or less to the work required such as sewing in gussets of drawers, such a stitch covering the raw edge nicely, besides sewing it on securely. They are sometimes used for covering the edge of the cloth left raw after running the necks. Sometimes a zigzag stitch is used with good effect on the facings of garments, or for making bars at intersections or parting of the seams on drawers, union suits, etc.

For covering the raw edge after running the neck, the Union Special Twin-Needle Machine makes a pretty ornamental stitch, as well as effectually covering it. It has two needles and one looper, leaving two parallel lines of stitching on the back and an interwoven fancy stitch over the raw edge of either silk, worsted or cotton thread, as preferred. It is the same stitch as made by the cylinder side-wheel covering machine, though the twin-needle machine, so called, for necking, is a regular flat machine. It is also sometimes used for catstitching, or wherever a pretty ornamental stitch is desired. Often it is called a Necking machine.

Twin-needle and *two-line machines* are often confounded. Two-line machines make two separate rows of stitching on both back and front of work, and require two needles, two loopers or hooks, and use four threads. Two-needle machines are by no means always two-line machines. For instance, the so-called twin-needle or necking machine, has two needles, but only one looper, and consequently runs but three threads. The side wheel covering machine is similar as to needles, looper and number of threads. In fact, the covering machine is simply the twin-needle machine redesigned in the form of a cylinder machine to facilitate the handling of the work.

Two-line machines are used wherever it is desired to have a double row of stitching, as on the outside of drawer band—covering the back seam of drawers with tape—sewing on each side of the tape simultaneously, being fitted with a device for holding and guiding the tape properly. It is commonly called a Taping Machine. Wherever two-row work is required, two-line machines are desirable, because the lines of stitching are more likely to be parallel, more slightly, and the work turned off much quicker. Two-line machines are built almost any width between the rows, from 3-32 to 13-32 of an inch. Special widths are made from 13-32 to 21-32 of an inch.

End sewing machines were formerly required, but where covered seams are made, and covered seams are almost universal, none are necessary. Almost any zigzag machine answers the purpose where such a machine is required, though there is a machine made especially for this purpose.

Hemming machines are used for shirts or vests, on flat goods, or rib-tails, either looped or stitched on, take the place of the hem. On ribbed goods, the hem is made on a machine designed for the purpose, the “concealed” stitch being much in favor, though edging machines are used for this finish in many instances.

THE LOOPING OR TURNING-OFF MACHINE

Within the province of sewing processes for elastic knitted fabrics, and the various more or less complex mechanisms with which they are severally executed, comes one which, in its final appearance, has the most satisfactory effect of all, from many standpoints. Yet, strange to say, its accomplishment is by means of a type of mechanism that is wholly at variance with all of the latter-day ideas which the modern sewing machine calls for. We refer to the familiar process of looping one piece of material to another, and as is well known, the finished product is nearest to perfection of anything in the art of joining two parts of a knitted garment.

The beautiful flat effect which is obtained by this peculiar method, and the effectual merging of the sewing thread with those of the fabric itself are features which have effectually combined to continue this abnormally slow process in use at the present time.

This looping machine—variously called *looper*, *turning-off machine*, or *ribber*—is extremely simple in construction, containing as

it does only the principal fundamental sewing-machine functions, and it has passed through but few radical changes since its inception years ago. Indeed, it requires no stretch of the imagination to recognize in its main features those of the original Elias Howe hoop wheel feed model for a sewing machine. Even so, it is today the only practical device which will do its work perfectly, owing to the prime necessity of first impaling each individual knitted loop of both parts of the fabric

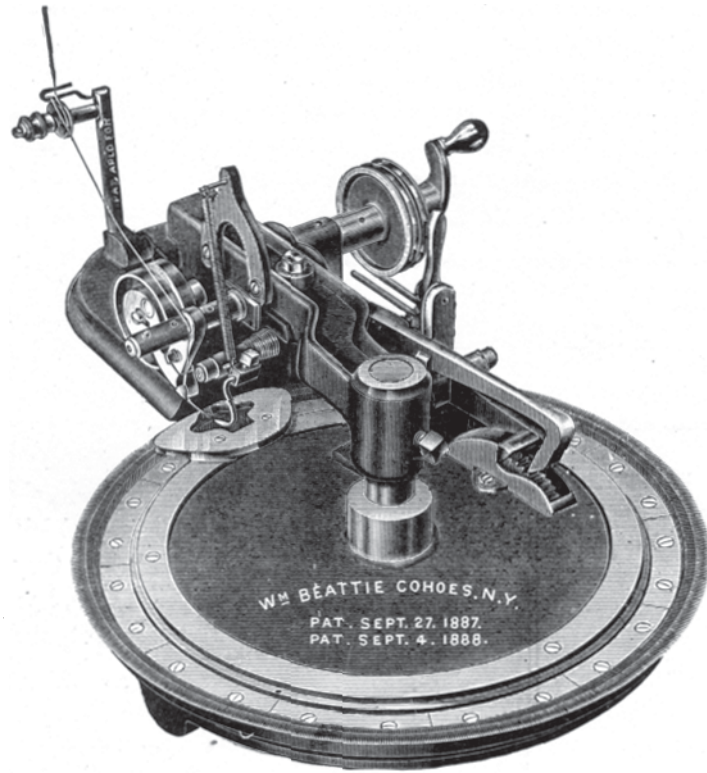

Fig. 26. Beattie's Looper or Turning-Off Machine.

to be united on a separate point or needle. It is from this peculiar fact that it is possible to cut, ravel, or trim, all surplus stock away from these loops before proceeding with the operation of sewing, thus producing in the opened-out joint, or seam, a result so perfect that the two parts thus joined will appear as one integral piece. Indeed, most people who wear such underwear think it is "knit that way," not knowing that the cloth comprising the body of a garment is knitted

on a circular machine, making a wale on one side only, and the firm but very elastic rib or cuff is knit on what is termed a *rib* machine. (Hence the term *ribber* previously mentioned as applied to one machine for joining these two parts together.) The rib-knitting machine is built on an entirely different plan from the circular one in that it has two sets of needles, and produces wales on both sides of the fabric.

In the rib machine, also, its needles are manipulated in and out of the yarn loops successively, as the fabric progresses in groups, which vary in number according to the desired width of rib or cuff being made, and as its motions are intermittent, the process of making this part of a garment is necessarily slow.

In the circular knitting machine the process is, as its name implies, circular and therefore continuous.

While the looper, or turning-off machine, is one where the operator works constantly, it is also working constantly itself, if speeded to the operator's gait. To the uninitiated, looking at the operator sitting on a low seat, putting the toes of a stocking, or the parts of the fabric to be looped, on the points of the disc of the machine, stitch by stitch, one loop on each point, it may seem easy, but it is soon apparent that quick and strong sight and nimble fingers are required, and also that the machine is capable of running much faster than the most expert operator can place the loops on the points in the proper manner to obtain perfect work.

Other Methods of Joining the Rib. From time to time devices and machines have been brought out that were designed as substitutes for, and to hasten this exceedingly slow process. Some of them have met with a fair amount of success for a time on certain classes of work, but none were acceptable on the finest grades of this fabric, so we still have the looping machine in almost its original form of forty years ago.

Of all substitute methods and machines for this purpose, perhaps the most satisfactory has been the one of utilizing the "Overlock" stitch. This consists of placing a row of these stitches along the edge of each part of the fabric, to be joined in such a manner that their loops form two continuous selvages, and a subsequent operation will join them. This method is much quicker, stronger, and produces the desired flat seam.

Other devices have been the so-called pin-wheel sewing machines of different types. In this plan the familiar wheel of points to hold and carry the fabric to the needle was retained, but the necessity of impaling each knitted loop on a separate point was eliminated by providing an exceedingly fine feed, with the result that while some of the uniting stitches would be made between the wales of the fabric, each knitted loop would receive at least one. This method proved to be a great time saver, but lacked the finished appearance of the genuine looping method, and it is not now used to any great extent.

Looper Trimmers. For the purpose of assisting the operator in her work, and to reduce the amount of time necessary for this operation of looping, various automatic devices have been introduced, whose office is to remove the surplus material projecting above the feed-wheel points, and prepare the impaled loops of fabric for the final sewing operation. This had previously been required of the operator herself, and while it did not take a great deal of her time, an expert being able to cut and brush away the ravelings very quickly, these attachments did show a percentage of saving by allowing the operator to devote her whole time to impaling the loops of the fabric on the looper points.

These attachments operate in various ways, the most practical embodying a combination of the cutting and brushing processes. They have been arranged for use on both the old-style looper and several of the substitute pin-wheel machines.

Straight-Bed and Circular Loopers. For convenience in handling the various classes of undergarments during the looping process, looping machines are made in two forms. One with a straight bed on which a row of work-holding points are mounted to project along one of its sides, and having the stitch-making group of parts assembled on a traveling carriage. This form of machine holds the work stationary while the needle-looper, etc., are automatically moved along the bed from point to point after each stitch is completed.

The other form of machine is a circular one, in which the work-holding points are mounted to project from the periphery of a disc about eighteen inches in diameter. In operation this disc is given an automatic rotary feeding motion on its axis after the completion of each stitch. Thus it will be seen that the operating functions of the process in the two forms of machine are exactly in reversed order,

one holding the work in position, while the stitches are inserted progressively along the prepared edge of the material, and the other proceeding reversely to carry the prepared edge to, and by a stationary group of stitch-forming implements. The first, or straight-bed form is more peculiarly adapted for use on what is called "full-fashioned" garments, and the circular form is most generally used for "cut goods."

Character of the Stitch. In both forms of machine the stitching functions are practically alike, and produce the same finished result. By different arrangements of these parts in their relation to each other, and to the automatic feed, as to time, etc., several styles of stitch may be obtained, such as the "single stitch," "under and over," and "through and through" or "double stitch," and may use one or two threads, each style of stitch having its peculiar advantage for the work in hand. In some makes of machine the needle, (always a curved one), works from the inside or butt end of the points, outward, and others work in the reverse direction.

Operation. In setting up the circular looping or "turning-off" machine, it must be fastened securely to a good table, similar in construction to the ones used for sewing machines. It

need not be as wide, however, as it is never required for holding the work during this operation, and also because the full diameter of the disc, and several inches more must overhang the table's edge so as to be sure and provide ample space for the work to revolve while depending from the feed points.

The two pieces to be sewed together or looped are fastened to the disc, so that one of the points shall pass through each of two courses of loops near the raw edges of the fabrics, which are in position with their faces together.

The rotation of this disc will then bring each pair of loops in succession to a point of exact registration with the needle, which travels in the arc of a circle directly over and parallel with each point when in this position. A groove or depression in the top of the points will allow the thread-carrying needle to enter each pair of loops, and

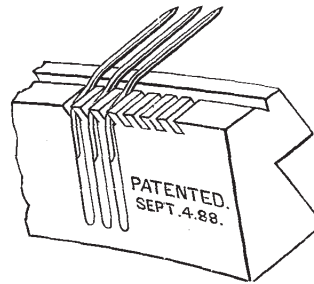

Fig. 37. Looper Points.

in conjunction with a properly shaped looper, which operates in time to meet the needle's thread, the two fabric loops are securely and almost imperceptibly joined.

In order that the machine may operate successfully and perfectly, it is necessary to trim the raw edges of material down to the loops that are impaled upon the points. Unless this is done and all the raveled threads and loose waste be removed before passing under the needle, the seam will be made with an unsightly welt.

The speed of the machine is limited to the ability of the operator in putting the loops of fabric on the points, and with those who are most expert it can never be run more than 300 or 400 stitches per minute.

Adjustments. If the machine skips stitches, examine the needle. If broken or damaged beyond repair, replace with a new one. If the point is dull make it over with an oil stone, care being taken to have the lower side as low as possible, so as to ensure its entering the loop. See that the point of the needle registers exactly over the center of each point. Skipping is also often due to the hook or looper getting out of adjustment. When taking the looper from the needle, the looper must slightly rub the needle when passing over it. The needle may move too quickly or too slowly and thus be out of time with the looper. When properly timed, the needle's point in entering the loop on the hook should be one-sixteenth of an inch from the hook, and just clear the heel of the looper. The hook, after passing away from the needle, will again move forward and pass under the needle, just touching it. The hook will be about one-eighth of an inch from the point brass when it is at its lowest drop. It is very essential to have the hook perfectly smooth and of such a shape as to keep the loop of thread from dropping off, and also to allow it to slip off easily before the needle enters the new loop. Keep the thread taut during the time the needle is passing through the loop. Have the thread rather too fine than too coarse for the needle.

In order to replace a point, remove the brass section that covers the base of the imperfect one, and remove it with a quick pull upward, thus preparing the groove for the new point. Place the new point in position, and with a small staking tool drive it to its seat, then with a hammer smooth the brass down around it, and finally replace and secure the covering brass in position.

The sewing mechanism must be timed with the points on the large disc, and if not exactly right their relative position may be changed by loosening the set screws in the main arm of the machine, and moving the disc to its proper position.

NAPPING KNIT GOODS

Brushing. Brushing is generally done in a machine similar to the one shown in Fig. 28. Many grades of goods are thus made to present a much more sightly and saleable appearance by being run through the garment brushing machine which raises the stock a

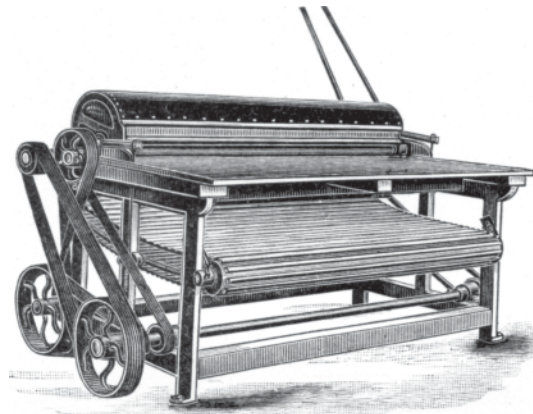

Fig. 28. Garment Brushing Machine.

little and gives the garment a soft and lofty feel and a more woolly appearance. It is customary to brush only the outside of the garment, but in some instances it seems desirable, for selling purposes, to brush both outside and inside, and in other instances it is run through the brusher twice to get more of the woolly appearance. These machines are not intended to tear up a nap like napping machines do, the rolls being made with stout, stiff bristles—instead of wire card clothing—that raises a light nap which has a tendency to give cotton or mixed goods more the appearance of wool. The process and the machine are shown in the illustration, and the samples of cloth shown indicate or illustrate the difference in appearance before and after brushing, the wale of the cloth being almost covered up by the nap after brushing.

Napping. A thread is tied into the fabric when it is being knitted, for the express purpose of making the nap, but it does not really form a part of the fabric. On goods where the nap is worked out of the fabric, without this backing thread looped in, it really destroys much of the strength and durability of the fabric, hence the introduction of the backing thread.

The great objection to napping on underwear is the tendency of the small fibers to roll up into lumps, and to become detached from the fabric in use, or to accumulate into hard lumps in washing. A close felted nap does not exhibit this tendency in so great a degree as one that is long and combed out.

The first nappers used on underwear made the nap by brushing with a rapidly revolving cylinder covered with a comparatively long straight tooth clothing which had a tendency to cut the loops and drag out the fibers into a long, hairlike fleece. This was objectionable on account of the amount of flocks detached from the fabric and the tendency of the nap to roll up or "pill," and led to the use of the tease gig, similar to those for finishing woven fabrics. This gradually worked out a shorter, felt-like nap, but was too slow and expensive, and the teasles were superseded by wire clothed gig nappers. These are of two kinds, *single acting gigs* and *double acting gigs*.

The single acting gig has a number of rolls journaled in a revolving cylinder and covered with wire clothing, all the points being bent in one direction. Means are provided for turning the rolls on their axes independent of the movement of the gig. This was an advantage over the brusher but is no longer used for underwear, as the double acting machine is better.

The double acting machine has the gig rolls in pairs, and a separate motion is provided for controlling each set so that they can be driven at different speeds, or, as compared with each other, in different directions.

The clothing also is of different shape, usually being straight or with a very slight pitch on one set of rolls and having a knee or sharp bend forward on the other set. The straight tooth or "carrier" rolls handle the cloth and hold it against the action of the bent tooth or "worker" rolls. They also help to release the fabric from the workers. The workers seem to dig into the fabric a certain distance when

the action of the carriers release their hold on the fabric and by repeating this movement rapidly work out the fibers of the yarns composing the fabric, into a short heavy nap.

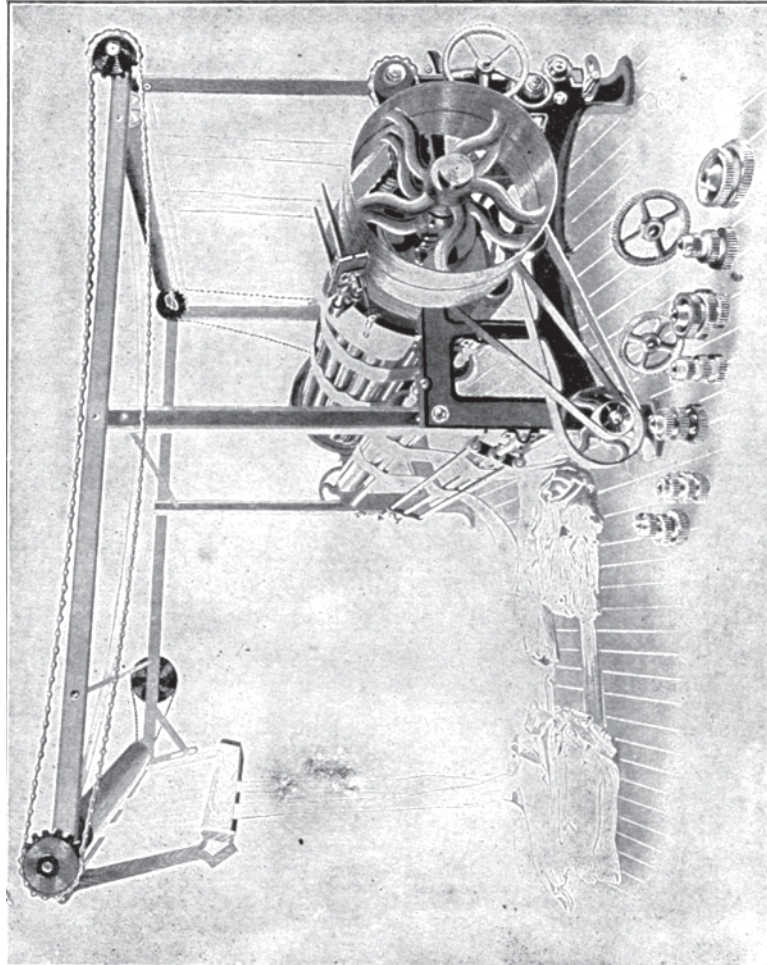

Fig. 29. Stafford & Holt Napping Machine.

On the Stafford & Holt Napping Machine, of which Fig. 29 is a view of the driving end, the gig runs contra-clockwise, or the top of the gig runs over toward the side where the cloth is fed in. The rolls in the gig turn in the opposite direction, that is, in a direction that will carry the cloth through the machine. The bent tooth rolls

are governed by a large internal gear on the driving end of the machine and the straight tooth rolls are governed by the internal gear on the opposite end of the gig. The function of the straight tooth rolls is to hold the cloth while the bent tooth rolls act upon it. They should be given enough speed to keep the cloth just slightly strained around the gig. A large change gear on the feed shaft loosens the cloth and a smaller one tightens it.

With a 96-tooth gear on the sprocket stud it would require from a 48 to a 56-tooth gear on shaft. The napping is done principally by the bent tooth "worker." With a 110-tooth gear on the sprocket stud, and a compound intermediate of 52 and 26 it would require from a 50 to a 21 pinion on the shaft for napping. The smaller the pinion the harder it will nap, say 38 into 52 and 26 into 110, the 52-26 being the compound intermediate, to be varied as required for the different fabrics and the character of the nap.

Napping "flat" goods, "straight-ribbed" goods and "jersey-ribbed" goods (or "fleece backs" and "plush backs") is better accomplished on *planetary* nappers, because they make a much shorter, thicker, and more evenly distributed nap than regular nappers, and give a more velvety feel. The nap obtained by this means is much less matted into knots or bunches by rubbing or washing, and the fabric handles much thicker and fuller, even after washing and use.

Planetary nappers contain, principally, a napping drum, a cloth feed roll, a series of napping-rolls mounted upon the drum and containing points inclined in the direction in which they act upon the cloth; crimper-rolls containing practically straight points mounted upon the napping drum and interposed in the series of napping-rolls, and a tension roll arranged to act on the cloth in advance of the napping action. The plurality of series of nap-treating members are mounted upon the drum, so arranged that a differential action is produced between the members of one series and the members of another series. The result of this action on the cloth is somewhat analogous to felting, inasmuch as the napper rolls raise the nap, and the other series of rolls serve to bend or crimp the fibers and drive them in making a felt or "fleece."

The mechanical construction of the David Gessner napper is described and illustrated to make the operation clear and comprehensive.

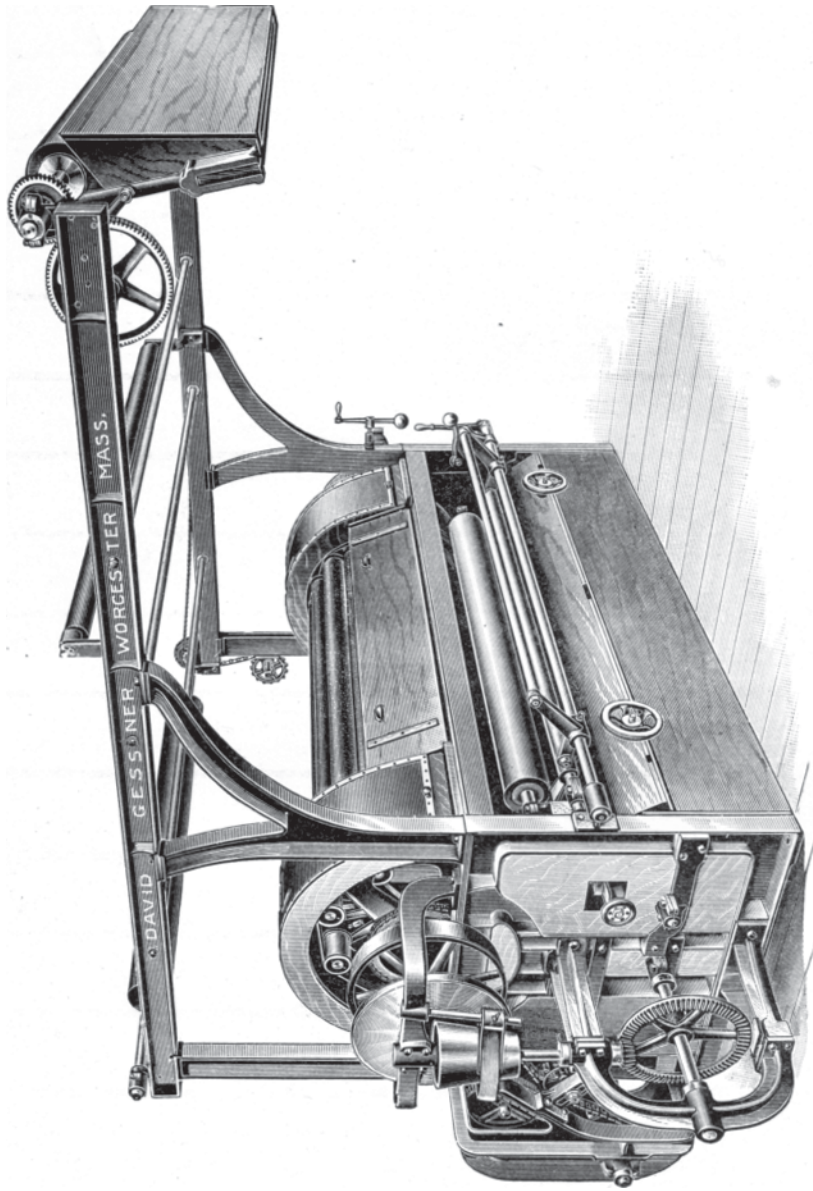

GESSNER KNIT GOODS NAPPING MACHINE
David Gessner

Referring to Figs. 30, 31, 32, and 33. The frame is composed of the upright end pieces 1 1', connected at the bottom by the girders

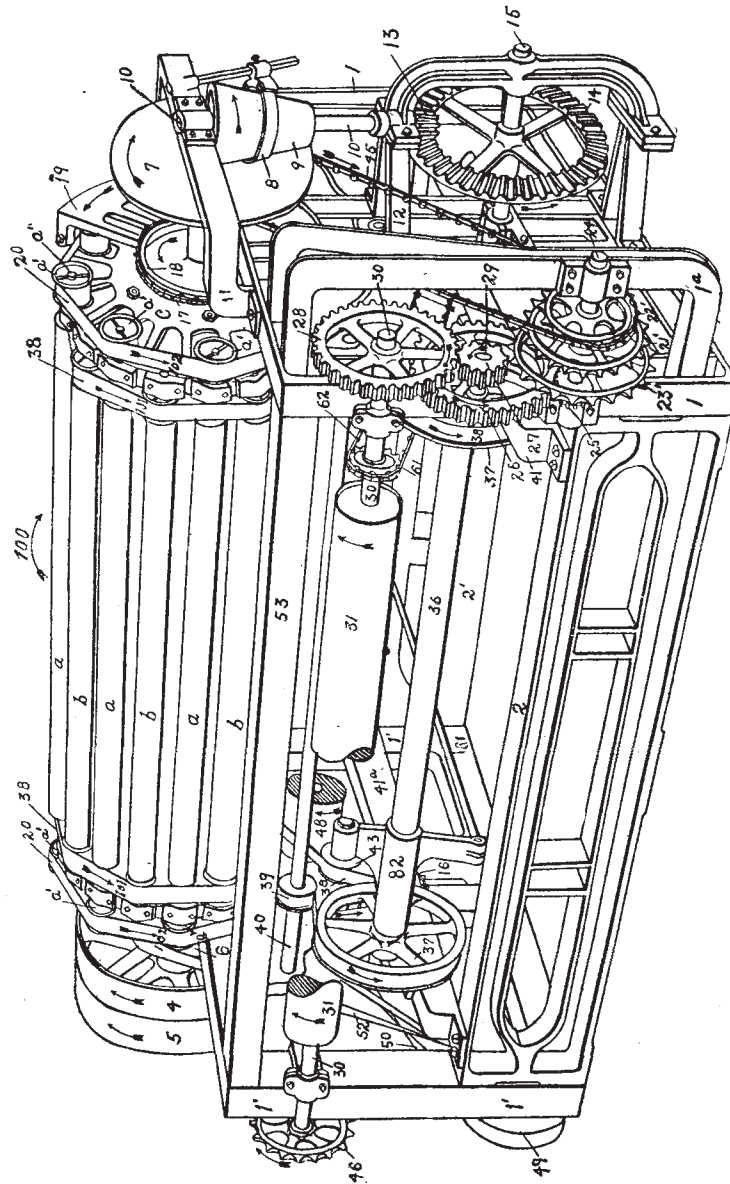

Fig. 33. View of David Gessner Napper.

2 2', which are united again crosswise by brackets or stays 41 and 41^a, and at the top by the girders 53 and 53' and carries upward

extensions 1^b 1^c and horizontal member 1^d , and a yoke on the side, marked 1^a .

Number 3 is the main shaft, carrying the heads $c c$, on the outer periphery of which are mounted the napping-rolls a and the contact-rollers b , which are called "crimper-rolls," because their contact against the ends of the napped fibers serves to bend or crimp the fibers with a result which is analogous to felting.

Number 4 is the fast pulley, by which the main shaft is driven, and 5 is the loose pulley. 6 is a pulley, fast on the main shaft, from which by the belt 52 is driven a pulley 52^a , fast on the inside of pulley 49, from which the shaft 47 is driven through the belt 50 and pulley 51. The stripper roll or fancy, 48 is fast on the shaft 47.

The napping-rolls a are covered with card clothing, the points of which are inclined in the direction in which they act upon the cloth. The crimper-rolls b are covered with card clothing having straight or radial points. The napping rolls, at their points of contact with the cloth, move in non-unison with the cloth, so that their points raise the nap. The two series of rolls act differentially, the napping series serving, as it were, to comb out the nap and the crimper series serving to crimp or felt the nap.

The mechanism for driving the napper-rolls a consists of the disc 7, fast to the main shaft 3, the belt 8 and the conical roller 9 co-operating with the disk, the shaft 10, upon which the conical roller is mounted, having its bearings in the brackets 11 and 12 and carrying at its lower end the pinion 13, which drives the gear 14, fast upon the counter-shaft 15. Upon this counter-shaft are fixed, on the inside of the frame, sprocket-wheels 16, 16, (there being one for each end of the machine) from which, through the sprocket-chains 17, are driven the sprocket-wheels 18, 18, (there being one at each end of the napping-cylinder), fast to the spiders 19, which carry the belt 20, which passes around the series of pulleys a' , a' on the ends of the shafts a^2 of the workers a . By raising or lowering the belt 8 any desired speed may be given to the workers a for increasing or decreasing their napping capacity independent of the speed at which the cloth may be running, and independent of the speed at which the travelers b may be running, and independent also of the speed at which the main shaft is running.

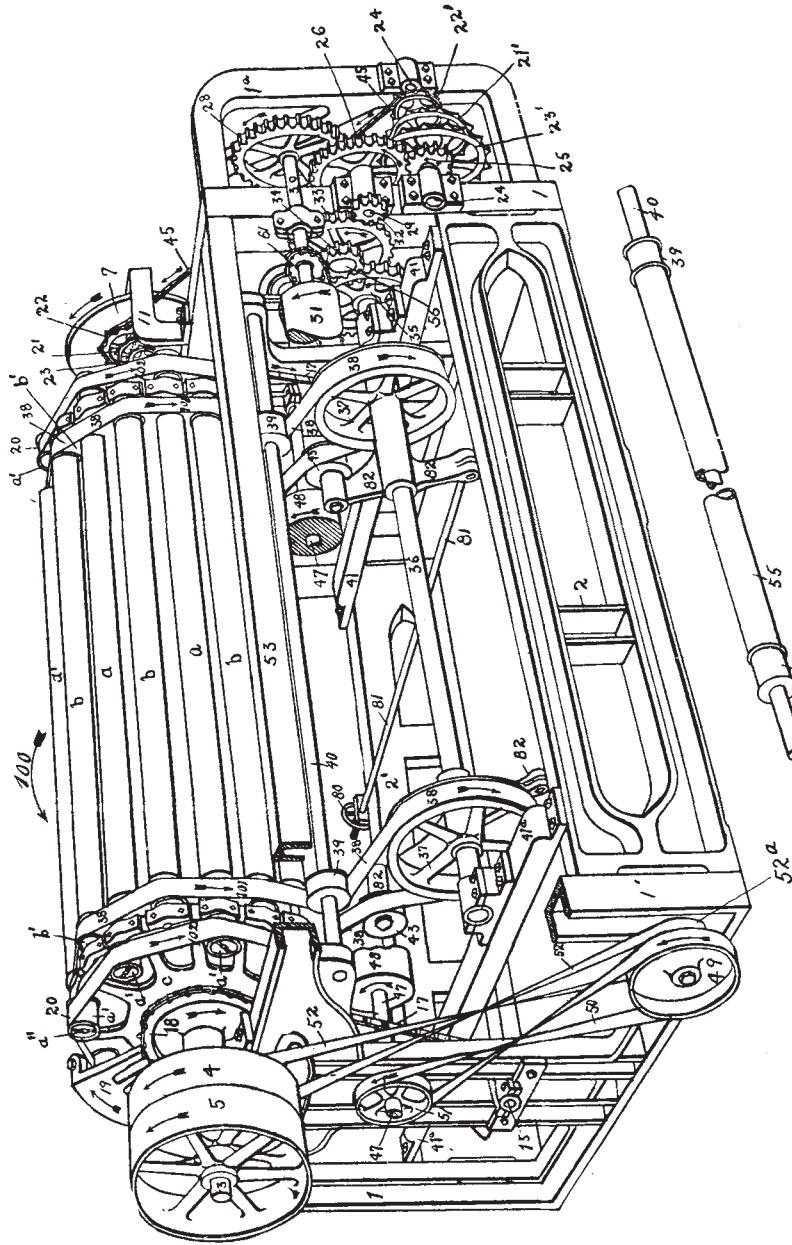

Fig. 31. View of David Gessner Napper.

The mechanism for driving the cloth-feed rolls, of which 31 is one, is as follows: 21, 22 and 23 are sprocket-wheels fast to the main shaft. 21', 22', and 23' are corresponding sprocket-wheels fast to the

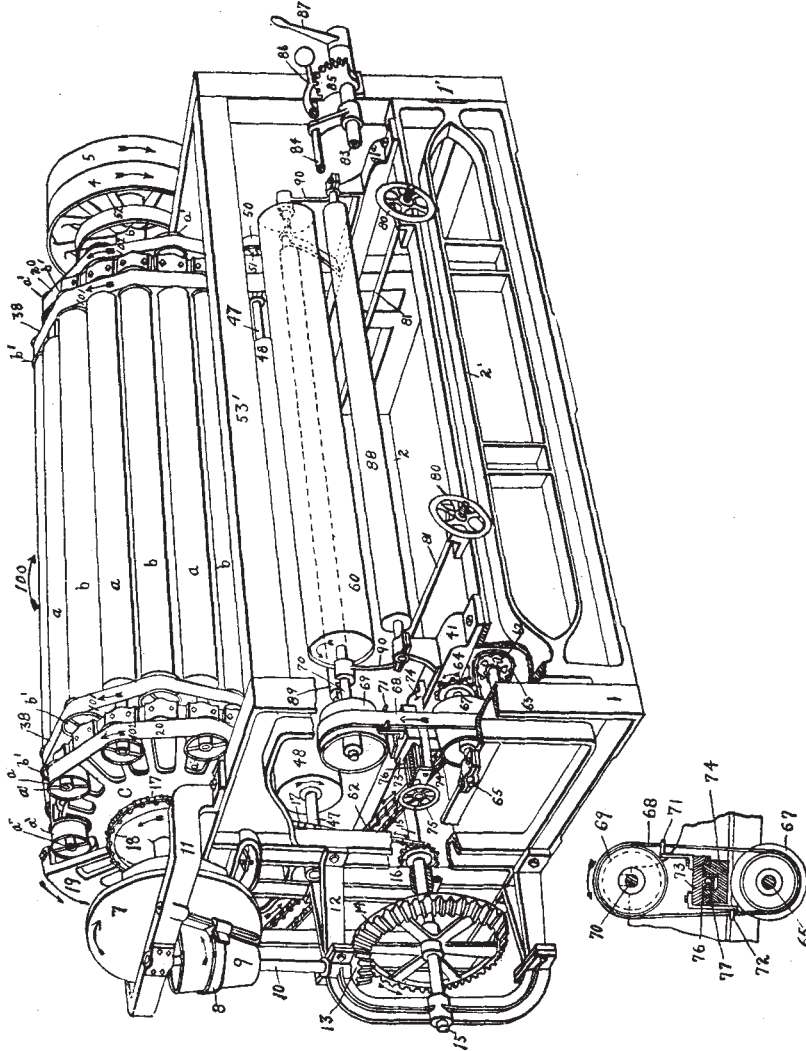

Fig. 32. View of David Gessner Napper.

counter-shaft 24. 45 is the sprocket-chain, by shifting which from one pair of said sprocket-wheels to another the speed of the counter-shaft 24 may be varied with respect to the speed of the napping-cylinder. 25 is a pinion fast on the shaft 24 and which drives a gear

26, fast on the shaft 29. The pinion 27 is fast to the gear 26 and drives the gear 28, fast on the shaft 30, to which shaft the cloth feed roll 31 is fast. On the opposite end of the shaft 30 is fixed the sprocket 46, from which may be driven all other cloth feed rolls in the machine.

The entrance tension-roll 60 is driven as follows: On the shaft 30 of the rear draft-roll 31 is fast a sprocket-wheel 61, which drives a chain 62, which drives a sprocket 64, fast on a shaft 65, carrying a cone 67, which drives a belt 68, which drives cone 69, fast on shaft 70 of the entrance tension roll 60. The chain-idler 63 serves as a take-up for chain 62. By shifting the belt 68 on the cones 67 and 69, the speed of the entrance tension-roll 60 may be varied at will relatively to the speed of the other feed-rolls and traveler-rolls. This adjustment is a feature of the utmost importance, because it vastly increases the scope of the machine with respect to the range of materials which may be successfully treated by the workers *a*. For the purpose of enabling this adjustment to be made while the machine is running, and to be regulated to a nicety, the following mechanism is provided, whereby the operator may shift the belt 68. 71 and 72 are belt-forks fastened to the carriage 73, which is made to slide upon ways on the bracket 74, fast to bracket 41. By a screw-spindle 76, with hand wheel 75, nut 77, fast to carriage 73, is moved so as to shift said forks and belt 68 at will by the operator while the machine is running.

By the adjustment last described the tension of the fabric being treated can be regulated to suit very tender fabrics, which by too great a tension are liable to be torn or stretched and narrowed, and by too little tension are liable to be dragged forward by the workers *a*, and thus slacked up in a manner causing disaster.

The mechanism for driving the crimper-rolls b is as follows: Upon the opposite end of the shaft 29 from the gear 26 is fixed a pinion 32, which drives a gear 33, turning upon a stud 56. The gear 34 is fastened to the gear 33 and drives gear 35, fixed on the shaft 36, having its bearings upon stays or brackets 41 and 41'. The pulleys 37, 37, are fixed on the shaft 36 and drive the belts 38, 38, which extend around the pulleys *b* at opposite ends of the crimper-rolls *b*. These belts 38, 38, run under the idlers 39, 39, and over the idlers 43, 43, respectively, so as to substantially encircle all of the travelers *b*. Whenever the chain 45 is shifted from one pair of sprocket-wheels to another for the purpose of varying the speed of

the cloth relatively to the speed of the main shaft, a corresponding variation will be produced in the speed of the belts 38, 38. Therefore any change in the speed of the cloth feed rolls, as 31, will be accompanied by a corresponding change in the speed of the crimper rolls *b*.

In the particular form of this machine the mechanism above described is so proportioned that the surface speed of the cloth feed rolls, as 31, is substantially the same as the surface speed of the crimper rolls *b*, which surface speed of the crimper rolls *b* is the resultant between the speed of the crimper rolls *b* upon their own axes and the speed at which they are carried bodily by the cylinder-heads *c*. In other words, if the diameter of each pulley *b'* is the same as the diameter of their respective crimper rolls *b* the belts 38, 38, may have substantially the same speed as that at which the cloth being treated is traveling through the machine.

The relationship between the speed of the crimper rolls and of the feed is maintained constant in the operation of the machine notwithstanding and independently of any variation which may be made in the speed of the working rollers *a* or of the main shaft. The shaft 29 constitutes a common actuator for the cloth feed rolls and the crimper rolls. The connections between this common actuator 29 and the cloth feed rolls, as 31, are invariable. Likewise the connections between this common actuator 29 and the crimper-rolls *b* are invariable, so that for a given speed of this common actuator a corresponding speed will be communicated both to the crimper rolls and the cloth feed rolls, and the speed of one will be invariable with respect to the speed of the other. In the connections, however, by which the common actuator is driven the shifting of the sprocket-chain 45 affords a speed adjustment whereby the speed of the common actuator 29 may be varied with respect to the speed of the other parts of the machine.

The belt 38 can be taken up and tightened by turning the hand-wheels 80, which are screw-threaded to the rods 81, that engage, respectively, with the swing-arms 82, which are loosely mounted on shaft 36 and carry on their free ends the idlers 43.

The broken line *d* indicates the cloth being treated. In leaving the napping-rolls it passes under a roll 55, fast to the two idlers 39, 39, and turned with them at the same surface speed as the surface speed

of the crimper rolls *b* by the power of belts 38, 38. Thence it passes under and partly around the feed-roll 31, under the weighted roll 54,

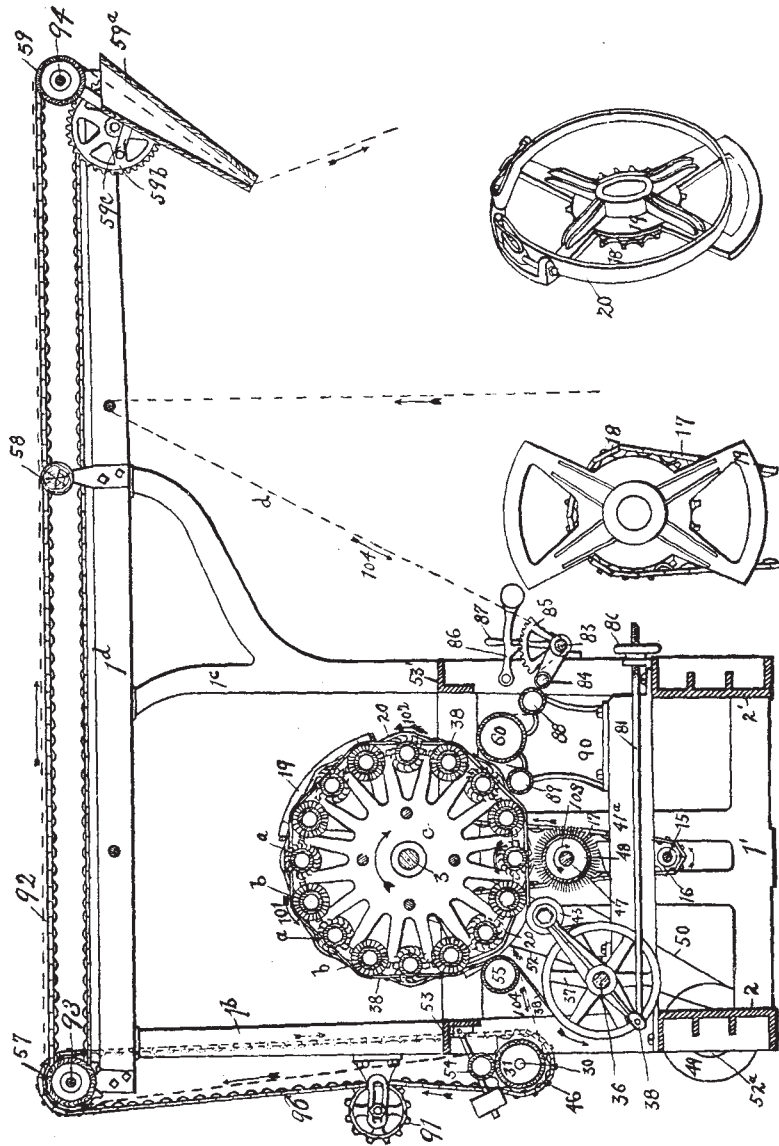

Fig. 38. Showing End View of David Gessner Napper.

upward and over the driven feed roll 57, over the idler 58 (overhead of the operator) and driven feed roll 59, whence it is delivered

through the folder 59² behind the operator. The chain 96 is held taut by the idler 91 and drives the shaft 93, to which the feed roll 57 is fixed. Thence the driving power is transmitted through chain 92 to shaft 94, on which feed-roll 59 is fixed. Thence the driving power is applied to vibrating the folder 59^a through the wheel 59^b and connecting-rod 59^c.

The cloth enters the machine under the bar 83 and over the adjustable tension-bar 84, the adjustment of which is controlled by segment 85, catch 86, and hand lever 87, at the end of the bar 83. Thence it proceeds under idler 88, over the tension roll 60, under and around idler 89, directly in front of the napping cylinder. The idlers 88, 89, and the tension-roll 60 are mounted in brackets 90, which are fastened to brackets 41 and 41^a, extending across between the girders 2 and 2'.

The directions of movement of the drum-cylinder of each series of napping-rolls, and of the cloth, are respectively indicated by the arrows 100, 101, 102, and 104. The direction in which the brush 48 moves is indicated by the arrow 103.

The result is a nap much shorter, thicker, more evenly distributed, and more like a felt or "fleece" than the nap raised on a regular napper, the fabric handling much thicker and fuller even after washing or use and much less liable to become matted into bunches by rubbing or washing.

REVIEW QUESTIONS.

PRACTICAL TEST QUESTIONS.

In the foregoing sections of this Cyclopedia numerous illustrative examples are worked out in detail in order to show the application of the various methods and principles. Accompanying these are examples for practice which will aid the reader in fixing the principles in mind.

In the following pages are given a large number of test questions and problems which afford a valuable means of testing the reader's knowledge of the subjects treated. They will be found excellent practice for those preparing for Civil Service Examinations. In some cases numerical answers are given as a further aid in this work.

REVIEW QUESTIONS

ON THE SUBJECT OF

KNITTING.

PART I.

1. How is the gauge determined?
2. What style of outside circles do you consider most advantageous, and why?
3. How is a fleeced lined fabric made?
4. Explain the function of the clearing bur.
5. Where would you begin to set a feed?
6. How would you prevent the needles loading up?
7. What are the three things to be considered in preparing to make Single Plush?
8. What ought to be first done when a Winder runs hard?
9. What is the method of determining the weight of the yarn?
10. Having less than 50 yards of woolen yarn how would you find the size or run? What is the run and cut of 12 inches of woolen yarn which weighs $1\frac{1}{4}$ grains?
11. Why is the Winder a necessary machine in a Knitting Mill?
12. What are the principal differences in Spring Needle Machines?
13. Describe the function of the take-up.
14. How many burs in a plain feed are located inside the fabric on the needles, and what are they?
15. What objects are to be considered in determining the proper speed to run the cylinder?
16. What three objects ought a Knitter to keep in mind?

KNITTING.

17. What is the composition of the lead?
18. How may some burs be changed to correspond to change in gauge of cylinder?
19. Which way of plating do you prefer, and why?
20. How should a double plush feed be arranged around the cylinder?
21. For what purpose is the Heart Cam made with a long and short side?
22. How many needles are required in a 20" cylinder to knit 20 gauge fabric?
23. How many motions are there to the cotton friction rail, and of what use is any motion to it?
24. State briefly the process of forming the stitches.
25. What is the most important matter to look after when an Evans friction cone is applied to the Winder?
26. How would you start up a machine without a fabric on the needles?
27. What is the ideal position to set a cast-off bur?
28. How would you proceed to even the stitch?
29. What are the "comparative tables" to be used for?
30. State how the run system differs from the cut system?
31. Having less than 50 yards of yarn why divide by 1,800?
32. Describe the functions of the backing bur.
33. Describe the correct method of setting a sinker bur or feed wheel.
34. Why are needles made in leads?
35. What style of a take-up do you prefer, and why?
36. What is the gauge?
37. What is the correct position for the holding-down wheel and what is its function?
38. With hard twisted or wiry yarn which style of presser would you use?
39. State the advantages of a trick needle machine and those of a leaded needle machine.

REVIEW QUESTIONS

ON THE SUBJECT OF

KNITTING.

PART II.

1. What effect does tucking the stitch have on the fabric?
2. Describe a 6 and 2 rib.
3. How is the tuck stitch made in automatic machines?
4. Describe what you consider the best method to even the stitch.
5. How does the royal rib or tuck stitch differ from plain rib knitting?
6. State the essential difference between a Plain and an Automatic Machine.
7. What is the pattern chain used for?
8. How are ribbed goods distinguished from flat goods?
9. What are the important members of a rib knitting machine?
10. If you desired to slacken the fabric, how would you proceed?
11. What extra work is done by the needle when tucking?
12. What is the take-up and what are its functions?
13. What is the advantage of the sectional cam ring?
14. Mention two conditions that will cause dropped stitches.
15. Describe the action of the hole and bunch detector.
16. How would you set a yarn guide or carrier?
17. How much space is it good practice to leave ordinarily between the needle cylinder and needle dial plate?
18. How would you proceed in replacing a press-off?
19. What are the advantages of the new method of measuring knitting machines?
20. Give a short description of how you would proceed to start up a machine that had been stopped for some time.

REVIEW QUESTIONS

ON THE SUBJECT OF

KNITTING.

PART III.

1. What is the difference between a Stationary Needle Cylinder Machine and a Revolving Needle Cylinder Machine?
2. What is the characteristic difference between the Leighton Machine and those common to the rib knitting type?
3. Describe the formation of the stitch on the Lamb Machine
4. How do common locks differ from cardigan locks?
5. How would you set a yarn guide on a Stafford & Holt Machine?
6. Give a short description of starting up a Scott & Williams Stationary Cylinder Machine.
7. What would you do in case the work persisted in rising up on the needle in a Lamb Machine?
8. How does knitting the royal rib or tuck stitch differ from knitting the plain rib?
9. How is the stitch adjusted on the Lamb Machine?
10. Describe the usual way of testing the amount of yarn the feeds are drawing and explain how they are adjusted.
11. How would you make a separating course on a Leighton Machine? What is it for?
12. How is a needle removed from the Lamb Machine?
13. Name some of the conditions which affect the speed at which a machine may be run.
14. Describe the action of shogging the stitch on the Leighton Machine.
15. What is the characteristic feature of the Lamb Machine?
16. Describe the functions of the latch openers.

KNITTING

17. In knitting tuck stitch, what extra work is performed by the needle and which bank of needles does that extra work?
18. What would you do if the whole fabric dropped off the needles? How would you replace it?
19. Give several causes for dropped stitches on a Leighton Machine.
20. What is the characteristic difference between ribbed goods fabric and flat goods fabric; that is, latch needle fabric and spring needle fabric?
21. How is the tension adjusted on the Lamb Machine?
22. What is a narrowing comb used for? Describe the operation.
23. How would you "thread up" to make plated goods on a Leighton Machine?
24. What is the effect on the fabric if the different feeds are drawing different amounts of yarn?
25. How is the tuck stitch made on the Stafford & Holt machine and what effect does it have on the fabric?
26. When knitting a welt, what limits the length of welt that may be made?
27. Describe what you consider the best method to even the stitch.
28. What is the cause when the needle makes a clicking or snapping sound when operating, and how is the difficulty remedied?
29. What is the advantage of having an adjustable throat?
30. How would you proceed to "slacken" the fabric, or loosen the stitch if it were too tight?

REVIEW QUESTIONS

ON THE SUBJECT OF

KNITTING.

PART IV.

1. How is the fashioning or shaping to the leg done on a circular latch needle knitter?
2. How is the fashioning or leg shaping done on a flat rotary frame?
3. How would you change the size of stockings?
4. Describe the difference in the character of fabric made by tight and loose by knitting.
5. Why is it necessary to have different numbers of slots in needle cylinders?
6. What function do the sinkers perform?
7. What are the primary elements of the circular knitting machine?
8. How many movements are necessary to the needle cylinder in knitting a stocking?
9. Wherein is the two-and-one method of making heel and toe superior to the one-and-one method in circular machine knitting?
10. Describe the operation of the lifting pickers in the Acme machine.
11. In what respect does the circular ribbing machine differ from the circular stocking machine?
12. What is a slack course?
13. What is a welt?
14. How is a welt made?
15. Which fabric is the more elastic, that knit on the circular latch needle frame or that of the straight rotary spring needle frame?

KNITTING

16. What are the primary differences between the circular latch needle frame and the rotary spring needle frames?
17. How is a "split-foot" stocking made on a circular machine?
18. How are rib-tops joined to the stocking leg?
19. Give a short description of the operation of knitting a stocking on an automatic machine.
20. What are commonly called the fashioning needles in a circular automatic knitting machine?
21. In knitting a stocking when are all the needles in operation?
22. What is the function of the sinkers or jacks in a stocking machine?
23. What is a winding or twisting device employed for?
24. How does the rib-top machine differ from the regular stocking machine?
25. How do the mechanisms employed to change the length of the stocking differ in the Hemphill and the Acme machines?
26. Referring generally to knit fabric—state your preference for spring needle fabric or latch needle fabric, and give your best argument in favor of the kind you prefer.
27. Is it possible to knit as fine a gauge fabric with latch needles as with spring needles?
28. Give the best reasons you can in favor of latch needle fabric, comparing it with spring needle fabric.
29. Why is it possible to make a more shapely stocking on a machine of the Schubert & Salzer or "Cotton's Patent" type, than on a circular latch needle type?
30. Give the best argument you can in favor of spring needle goods, comparing it with the faults of latch needle goods.
31. Yarn, gauge, and other conditions being equal, do you consider a ribbed fabric knit on spring needles as good as that knit on latch needles?
32. State why you prefer a latch needle machine of the revolving take-up type, or why you prefer one of the type in which the take-up does not revolve.
33. Which is the more elastic fabric; that knit on latch

KNITTING

needle circular machines or that knit on straight spring needle machines?

34. Will latch needle ribbed fabric retain its elasticity as long as a spring needle ribbed fabric?

35. State the advantages, if any, of the straight spring needle machines over the circular latch needle machines.

36. What are the advantages, if any, of circular spring needle fabric over the circular latch needle fabric?

37. How is narrowing and widening effected on straight rotary frames of the Schubert & Salzer or "Cotton's Patent" type?