

CHAPTER VII

GAUZE

THE principle of weaving gauze with shafts and healds applies equally to making it with a harness, though perhaps the latter is simpler, as there is not the same trouble in the arranging of drafts ; and, in intricate work, the number of doup leaves required for shaft mountings adds considerably to the trouble of the weaver and tackler.

The simplest, or in any case the most ready, method of weaving gauze in a harness, is to use an ordinary harness, and form the gauze by means of one or more doups and standards in front of it. Suppose we have a 400 machine with the harness tied up in simple repeats of 400 ; any desired pattern can be put upon the cloth to the extent of 400 hooks of the jacquard as in ordinary harness work, but it cannot be made of any texture desired—it must be made to suit the working of the doups in front of the harness. If the open work is to be a plain gauze with one shot into each shed, then the pattern must be plain cloth, as the doup standard must be raised and sunk alternately for each shot ; but any desired form or figure can be made in plain texture on the 400 hooks, and the cloth will consist of a plain figure on a gauze ground ; or it might as well be a gauze figure on a plain ground.

Those not acquainted with figured gauze work, have considerable difficulty in understanding how to make plain or gauze as required on the cloth.

It is easy to understand that working the harness without the doups can make plain cloth, and also that working the doups and standards, and portion of the harness, for alternate shots, can make gauze ; but the difficulty is to thoroughly comprehend how, when working gauze, to neutralise the crossing of that portion of the warp

that is to form the plain figure. There are two ways of neutralising the crossing effect of the doups on any thread or number of threads that may be required for the figure: first, by not raising the mail or mails carrying the crossing threads, or threads in the doups, but forming the plain by raising the mails carrying the threads not in the doups, alternately with the doup standard; and, secondly, if the threads not in the doups are raised along with the doup standard, no crossing can take place; but this would not suit for working plain cloth, as these mails must be down when the doup standard is up in order to form plain cloth.

If a different gauze is required, say one with 2 shots into each shed, or between the crossings, then the solid texture might be a rib or mat; or if it suited the pattern, as in the case of dice work, two doups could be employed, so that one could rest when the other is working the gauze. Fig. 126 is a plain gauze and plain texture, common dice pattern, which could be wrought with shafts, but shows the principle of working with the harness as well. This could be wrought with one doup in front of the harness. To work the dice A the

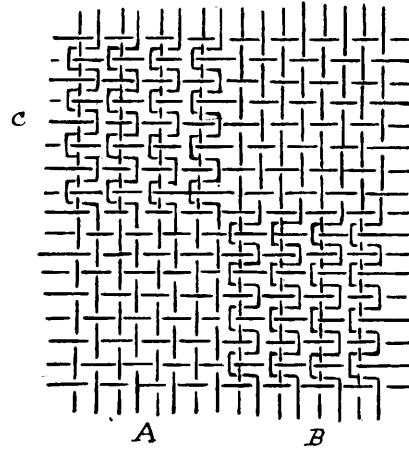

FIG. 126

mails carrying the threads not in the doups would be raised alternately with the doup standard, and thus form plain cloth; and at the same time, to make the dice B a gauze, the mails carrying the threads in the doups would be wrought alternately with the doup standard. For the dices C and D, this would be reversed. In case of the gauze having to be made with, say, 3 shots into each shed, and 2 threads twisting round 2 to give openness of texture, it will be seen that it could only be wrought with one doup, provided 3 shots went to each shed of the solid dice, as the doup would require to be up for 3 shots in succession, and down for the same. If plain cloth were required it would be necessary

to have a doup and standard for each dice, so that one could remain down when the other is raised for gauzing; this would allow the harness to work any texture on the solid dice, the doup of which is not gauzing. If it were required to work a diagonal stripe of plain and gauze, as shown in Fig. 127, with 2 weft shots coming in between each crossing of the gauze, 6 doups would be required in front of the harness, whereas if only one shot came between the crossings only one doup would be required. It will be seen that there are 6 splitfuls of

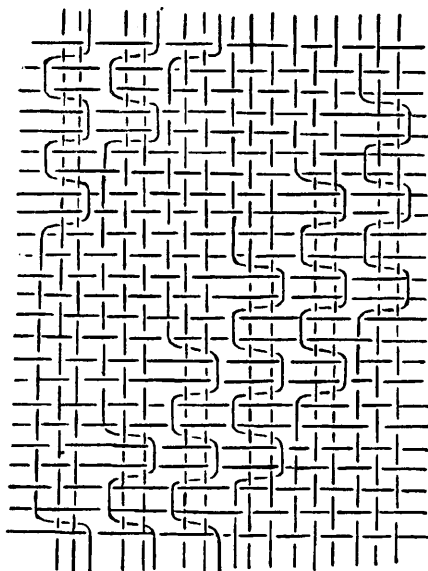

FIG. 127

warp to one repeat of the pattern, and that the change from the plain to the gauze is at a different time for each; therefore, on account of the doup standards having to be raised for 2 shots in succession when a portion of the cloth is plain texture, it is necessary for each splitful of warp to have its own doup so that it can be crossed without interfering with the plain texture in the other portion of the cloth.

This pattern would be better suited for a shaft mounting than for a harness

with doups in front, but could be wrought with a gauze harness more easily than with either. The advantage of using a harness with doups in front, in this case, over a shaft mounting, would be that the plain stripe could be figured if desired, and the gauze stripe might go in steps of two or three splitfuls alike, which would give much bolder stripes.

When more than one or two sets of doups would be required to be used in front of a harness, it is advisable to adopt a true gauze harness, as the doup shafts come in the way of the weaver. A gauze harness

has the doups in the harness, so that they can be lifted independently, which admits of indiscriminate figuring on either the gauze or solid portion of the cloth.

When using doups in front of the harness it is not necessary that the plain or solid cloth should be all a plain or unfigured texture; any suitable warp figure may be formed on the plain by the harness, but weft figures cannot be made on the upper side of the cloth, because, though the harness can be raised for any number of shots in succession to form a figure by the warp, having it sunk would not in the same way form a weft figure, as in crossing the gauze a portion of the yarn would be raised by the doup standard, which cannot be prevented, unless by having more doups than one. A harness with doups in front is better suited for working stripes than any other class of work, and it is in this class of work that gauze can be made most effective.

When figuring with gauze, unless several shots are thrown into each shed, or between the crossings of the gauze threads, and 3 or more warp threads are twisted together, the openness of the texture is not sufficient to make a good contrast between the plain and gauze unless the fabric is very light; and even with 2 threads round 2, and throwing 4 to 6 shots into each twist, the contrast is not so great as might be desired when the cloth is heavy. A portion of the weft, say every second or third shot, might be made to pass either over or under the gauzed texture and interwoven only with the solid portion of the cloth, the flushed or loose weft to be cropped off afterwards. In stripes, not only can this be done, but the warp may be set much thinner or wider in the reed for the gauze: say every second or third split may be left empty; or it may be of a different description of yarn—a fancy twist if desired, or in threads of different colours. A fancy stripe with three threads to the split in a reed, set 30 splits per inch, and every second split of the gauze portion left empty, makes a very effective pattern for fine work, with say 80 picks per inch; or 120 picks might be used, and every third or fourth one not wrought into the gauze, but flushed over to be cut off afterwards. There might be 2 thick threads or 4 finer ones to each split of the gauze, and 4 to 6 shots into each crossing, this, of course, to be regulated to suit cir-

cumstances and taste ; one thing must, however, be remembered—viz. that when made too bold or open the warp ribs are liable to slide on the weft, and this is the chief defect in gauze when made open, especially when a smooth, clean yarn, as linen, is used.

When working stripes, any pattern, or any texture or style of cloth, whether single, double, or pile work, may be used for the solid stripes,

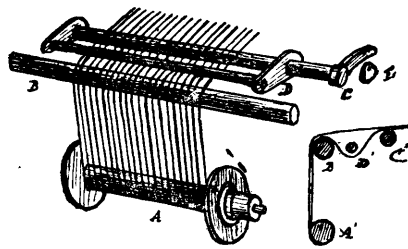

FIG. 128

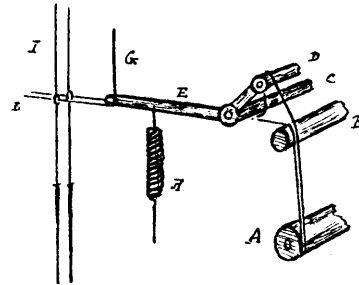

FIG. 129

or the whole cloth may consist of stripes made of combinations of gauze and solid textures. One set of stripes may be wrought quite independently of the other by having the yarn on separate beams, and when only one set of stripes is gauzed, the others are not drawn into

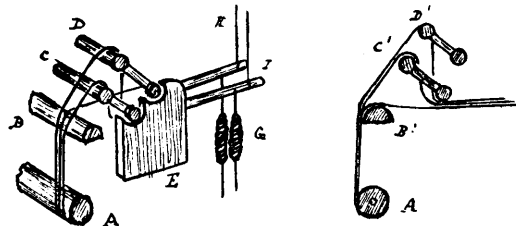

FIG. 130

the doup heddles, so are quite independent of them. The doup heddles may be spaced or otherwise as desired. When working with doups in front of the harness, there must be a slackener for the crossing threads for each doup standard, same as for heddle work. Figs. 128, 129, and 130 show some of the methods of slackening in use. In Figs. 128 and 129, A is the yarn beam, B the back rail, c and D the vibrating bars or slackeners, c acts as a fulcrum ; and in Fig. 128 the bar D presses

the crossing yarn down and is raised by the tappet ϵ , which may be either above or below a lever on the end of the bar c , a spring on the lever regulating it, to hold it against the tappet. In Fig. 129 the bar d is sunk to relieve the crossing yarn, by drawing up the cord g , which is attached to the jacquard or dobbie, the spring h holding the lever ϵ down when it is relieved. Fig. 130 is similar to Fig. 129, but for two doups; it is shown both in perspective and in end view, and will be clearly understood. c and d must be set at such a distance above each other as will permit of the traverse of d without c being moved. Two or more shafts of heddles might also be used which could hold the crossing yarn either up or down, same as the bars, till they are acted on by the jacquard or by a tappet.

Designing.—When designing a pattern for gauze, with doups in front of the harness, it is only necessary to set off a few hooks of the jacquard to work the doups and slackener, and design the fancy portion on the remaining hooks; or if the gauze and slackener are wrought with tappets the full jacquard will be available for the figured portion, the same as if no gauze were being made. If the doups and slackener are to be wrought by the jacquard the pattern can be painted on the remaining hooks, and the dots for working these can be added afterwards, agreeably to the texture of the gauze required. The doupstandard and slackener should act together, and the doup or half leaf should rise when the harness carrying the crossing threads rises. If the doup standard is to be raised every second shot, as is required when plain cloth has to be wrought with one doup, it might be wrought by a tappet, and the doup or loose heald might be raised by the machine for every shot, as it must rise with its standard as well as when the harness raises any of the yarn drawn into the doup. The doup shaft is best held down by a light spring. Indiarubber about $\frac{3}{16}$ or $\frac{1}{4}$ in. in diameter suits very well. One spring at each side of either one or two ply of this should be sufficient. If the number of rows in the harness is such that it will correspond with the number of threads to be twisted together, or be a multiple of them, it will be all the more convenient, though it is not necessary for it to be so. For instance, if 1 thread is twisted round 1, =2, an 8-row harness would give 4 repeats of this

in each row ; but if 1 thread were twisted round 2, =3, then 1 row of the harness would give 2 repeats, or hold 2 splitfuls of warp and 2 threads over, so that another thread would have to be taken from the back of the next row. For this a 6-row harness would be more convenient, which could be got by leaving 2 rows of the machine idle, and designing the pattern on 6-row paper, or ruling 8-row paper to 6-row after the design is painted. To work fancy textures with gauze by means of a harness with doups in front, both must be arranged to suit each other, unless a large number of doups be employed. For instance, a 2-and-2 twill could be wrought with 1 doup leaf in front of the harness by making 1 thread of the gauze twist round 3, and throwing 2 shots

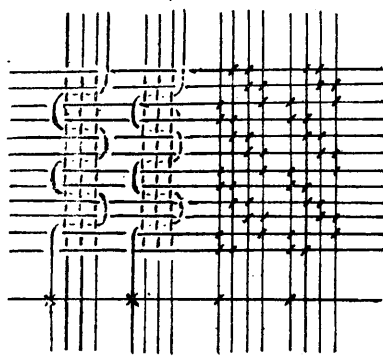

FIG. 131

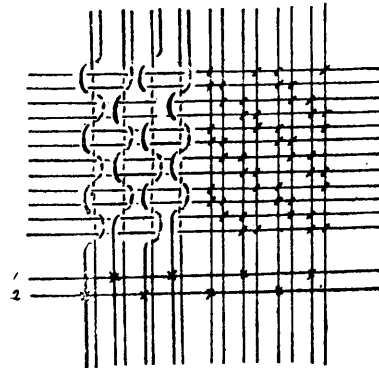

FIG. 132

into each crossing, as shown in Fig. 131. If 1 thread were to be twisted round 1 with a 2-and-2 twill, and 2 shots to the gauze crossing, 2 doup leaves would be required, as shown in Fig. 132. A 4-thread fancy twill can be wrought with 1 doup, as shown in Fig. 133, 1 thread twisting round 3 and 4 shots into each crossing of the gauze. Satins or regular twills are more difficult to work, unless by making an irregular gauze. Take a 5-end satin, which has the threads over 4 and under 1. The gauze might have 4 shots and 1 shot into each crossing alternately, and be easily wrought with 1 doup ; but if 2 or 3 shots had to go to each crossing it would be different, as the doup would require to sink for .1 shot out of 5, in order to let the threads drawn into it bind in the

twilled portion of the cloth, or otherwise the binding would have to take place on these threads when the doup is down, which it could do if it suited otherwise. But it must be remembered that when solid cloth and gauze are working together, the former is made by raising the doup standard and those mails which carry the threads that are not drawn into the doup, leaving stationary the mails carrying the crossing threads, except where gauze is being made; therefore, in working a 5-end satin, if the doup held up any of the threads for, say, 3 shots, and then sank for 3, there would be no way of holding up these

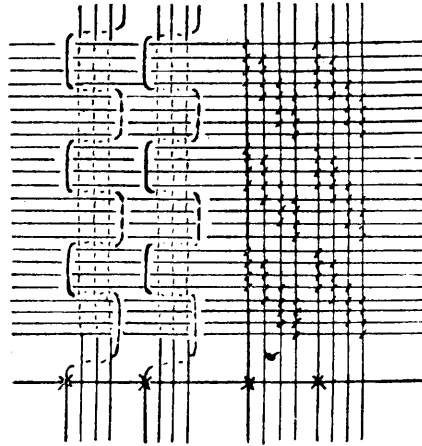

FIG. 133

threads in the twill portion to make them pass over 4 shots, as a 5-end satin must do, for if the harness twines carrying these threads are raised, they will cause a cross to be made instead of completing the twill. Patterns of this description should all be wrought in a gauze harness. In the figures given the gauze crossings are represented by dotted lines where they are raised by the harness, for sake of distinction.

HAND-LOOM GAUZE HARNESS.

A large quantity of goods are still being made in the hand loom on the gauze principle. These are mostly for curtains known as Cretes or Madras muslins, and for antimacassars or chair backs. They are chiefly woven in and about Glasgow, and in Newtownards in the North of Ireland. These goods are made on the half-harness principle—that is, half the warp is drawn into the harness and the other half passes through the harness and is drawn into a set of heddles in front. This mounting is shown in Fig. 134. It will be seen

that every alternate thread is drawn into one of the harness mails and all the threads are drawn through a pair of clasped leaves of heddles A B; those that are drawn into the mails are drawn through the under clasp of the leaf A, and those that are not in the mails through the upper clasp of the leaf B. The threads are next drawn through the doups as shown, those in the mails being in the back set, or upper doups. These doups are made different from those generally used, the doup or half-heald being connected with two standards; this is for the purpose of throwing less strain on the yarn. When the harness is drawn the shaft A is also raised, B being sunk, as well as

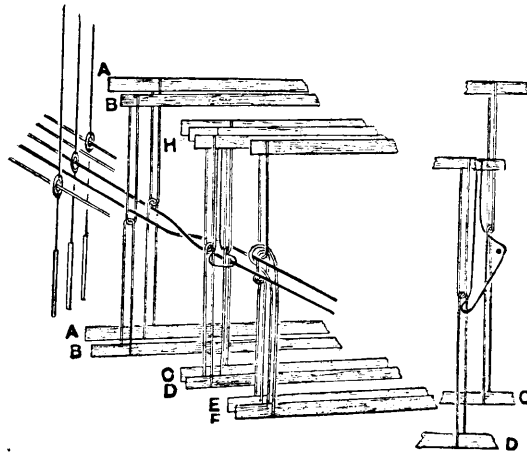

FIG. 134

FIG. 134 A

the front set of doups. As the yarn in the harness is also drawn through the back set of doups, it follows that they must be relieved to allow the harness to raise the yarn. This might be done, and sometimes is done, by sinking the ordinary doup shaft and letting the yarn draw the doup through its standard; but in this case the standard c is raised, which allows the thread to rise in the doup, as shown at Fig. 134A, without having to draw it up, and at the same time all the doups are kept firm in their places by the standard d, thus preventing any entanglement in a fine set of doups. The distance between the harness and back leaves is 4 in., and between the back leaves and gauze

mounting 3 in. The cloth is a plain gauze, and the figure is formed by throwing one or more shots of rove weft, either white or coloured, into the shed formed by the harness flushing over the ground and clipped off afterwards. To form the figure shed, draw the harness, raise the leaf A and the standard c, and sink the other leaves, making a rising and falling shed, or centre shedding. To form the gauze, for the open shed raise B C D and F, and to form the cross shed raise E and F, in both cases sinking the others. For these sheds fine or ground weft is thrown in, the flowering shots coming between them. The shafts A and B are for the purpose of keeping a clear shed, but might be done without. These goods are now largely made by power looms, principally with gauze reeds, which see.

GAUZE HARNESS

In a true gauze harness the doups are connected with the mails or leashes of the harness, the harness twines, or leashes, acting as standards for the doups, so that any splitful of warp may be crossed or twisted differently from the others, and any kind of texture can be wrought along with the gauze without having to consider the one in connection with the other, as in the previous harness. Figs. 135 and 136 show how these harnesses are tied up; the letters refer to the same parts in both figures. The harness is shown with four cords in the row, for the back harness and the doup mail in front, and this could be repeated twice for an eight-row harness. It is better to have the rows of the harness regulated in this way to suit the gauze to be made, and have the doup leashes in one or two rows at the front, but it is not necessary for it to be so, as the doups could come on any of the mails through the harness, if desired, in case of a harness being tied up, and it being wanted to add the doup leashes for gauzing; but this is rather confusing. In any case, this method of working is now superseded.

A is the doup or dead leash, B the doup standard, or what answers to the doup standard in heald work. C and D are the leashes carrying the plain or lying threads, and E the leash carrying the crossing

thread, the crossing in this case being one thread round two. F is the doup. Fig. 136 shows the harness drawn for the open shed, and it will be observed that the dead leash A is connected with the back harness E, so that when this leash is raised to form the shed it draws up the dead leash, also relieving the doup. There was one trouble with these dead leashes—namely, that they were liable to twist round the standards when close to them in the cumber board, sometimes being put through the same hole or the next one; but by having them

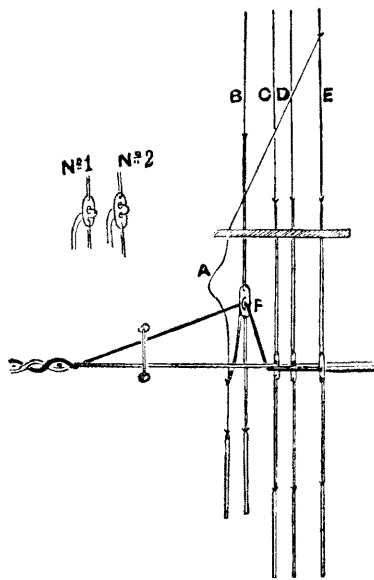

FIG. 135

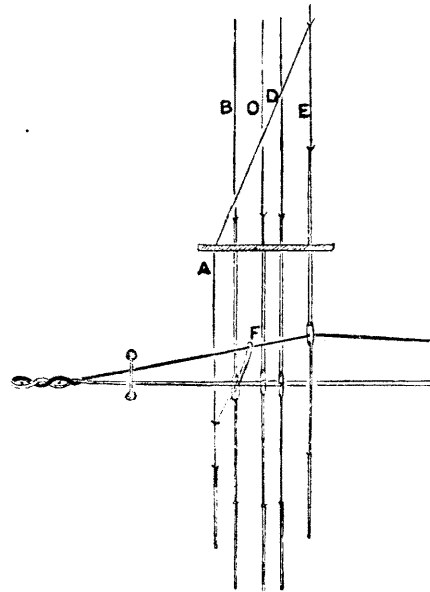

FIG. 136

in front and a little distance off this could be avoided. Wires or cords were sometimes stretched across between the lingoes to prevent the twisting. Fig. 135 shows the harness drawn for the cross shed, the doup standard being drawn up, drawing the doup up with it. The doup was fastened into the mails as shown at No. 1, Fig. 135; but a better plan is to have double-eyed mails, and fasten the doup as at No. 2. This form of harness is now superseded by one having all the doups on a shaft in front of the harness, which consists of two parts

— namely, the back harness and the douping harness (which is about $\frac{3}{4}$ in. to $1\frac{1}{2}$ in. in front of the former); the doups are connected with this latter harness, and all the doups may be on one shaft, whether for one, two, or more rows of standards in the front harness. The doups on the shaft are known as a 'slip heald' or 'slip.' This is a much simpler and more convenient method of working than the preceding.

Fig. 137 shows a simple and effective gauze mounting for a 4° jacquard, the cords being carried up to the machine in the usual way. A is the breast beam of the loom, B the reed, C the back rail, and X the yarn beam. D is the slip heald, or doup, which is simply a half-

leaf of ordinary clasped heddles, made of cotton or worsted, fine or coarse, as may be desired for the quality of work to be wrought. E is the front or doup mounting, connected with the two front rows of the machine, and passing through a small cumber board in front of that for the body of the harness; it is bolted so that it can be shifted to

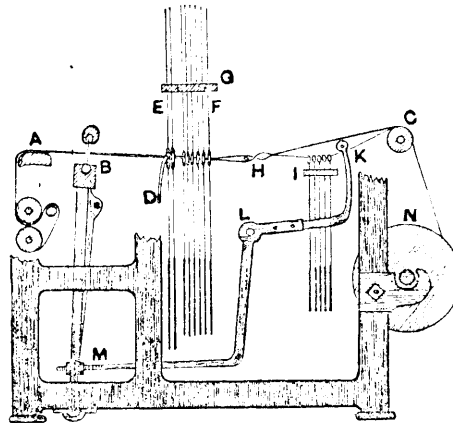

FIG. 137

regulate the distance between the doup harness and that of the figuring. The distance between the two harnesses may range from $\frac{3}{4}$ in. to $1\frac{1}{2}$ in., or whatever is found most suitable to ease the strain on the yarn and make a clear shed. G is the cumber board, and F the body of the harness for working the figure.

The method of slackening the threads that are drawn into the doups is perhaps the principal feature of this mounting. When one or more slackening bars are used it is plain that all the threads that pass over the bar that is oscillated will be slackened at once, though for figured work it may be that only a very few of these threads should be slackened, and if the remainder or any portion of them are raised by the back

leashes they should be kept tight at the back so as to enable them to draw up the slack doups. It follows, therefore, that for giving good work and keeping the threads at a regular tension, every thread in the doups should have its own independent slackener. It is not absolutely necessary that this should be so; strong twist cotton or worsted yarn will work very well in a harness with one slackening bar vibrating for each shot, though it must throw an irregular strain on the yarn, and it requires to be tightly paced.

In Fig. 137 the slackening arrangement consists of a small back harness, as shown at I, through which all the whip threads are drawn; these threads then pass over one lease rod and under the next one, as shown, and then on to the harness to be drawn in according to the draught of the gauze. The harness consists of small mails attached to lingoes with twines in the same way as the lower portion of the ordinary harness is prepared, but the mails are rounded off above the eye or centre hole without having the top hole for threading the upper portion of the harness to. The cumber board of this harness must be nicely set, so that the lingoes will hang on the yarn without drawing the mails quite close on the cumber board, which soon would cut the twines. To regulate this the cumber board and back rail must be set in relation to each other and the mails of the harness so as to produce the desired effect. A medium position for working may be taken as follows:—Cumber board 12 in. behind harness and 6 in. in front of back rail. Back rail 2 in. above the level of the mails in the main harness, and cumber board of small back harness 3 in. below the level of the mails, or 5 in. lower than the top of the back rail. The back lease rod might then come in about 8 in. behind the harness. The weight of the lingoes on the back harness must be regulated to suit the strength of warp to be wrought; about 30 to 40 per lb. for, say, from 40/2 to 80/2 cotton would suit. The mails for the body of the harness may be 25's or 30's, or the same as for ordinary work, and those for the doup standards heavier, say 18's or 20's. In addition to this harness for slackening, or rather for keeping a yielding tension on the whip, there is a slackening bar supported by a lever *KLM* at both sides of the loom. This lever has its fulcrum at *L*, and is attached to the swords

of the lay at π , and therefore vibrates at every beat up. The slackener acts as a positive motion, and keeps the threads from tightening up or being drawn forward by the twisting; it acts on the body of the threads, and the harness acts on them individually.

This, when properly set, is an easy motion, and produces a good firm gauze. It is a Bradford patent. Now, in reference to the working of the gauze: The harness is levelled much in the same way as for ordinary work, the mails being $1\frac{1}{2}$ in. or $1\frac{3}{4}$ in. below the level of the breast beam. The doup mails should be a little lower than those for the harness, say $\frac{3}{4}$ in. or $\frac{1}{2}$ in.

The shed should be closed, and begin to open again when the reed is at the fell of the cloth. Too large a shed should not be made with the doups, on account of the strain on the yarn: a small clear shed gives much more satisfactory work. The front cumber board, containing the doup leashes, may be shifted a little forward or back if thought desirable, so as to get the cross shed to spring as easily as possible, the amount of elasticity in the warp varying this considerably. The slip heald is raised for every shot by cording it to the brander or griffe of the jacquard, which for gauze work is generally a single-acting one. Springs are used for holding down the slip—a light wire spring, or, better, a piece of round indiarubber about $\frac{3}{8}$ in. in diameter, doubled if necessary. Bridles should be attached from the shaft of the slip heald at each end and fastened to the cumber board so as to bear the draw of the springs when the harness is down; the cords connected with the jacquard for raising this shaft may then be left slack, and the size of shed may be regulated or made less than the draw of the machine, if required.

It is very important to have the doups nicely adjusted; on this depends their lasting capacity, and sometimes a very short time is sufficient to cut them to pieces if badly set. But if correctly done they will generally last for a length of time, particularly if occasionally turned on the shaft, which is more essential in working with a linen than with a cotton warp.

One of the doup standard mails with a doup through it is shown at No. 1 (Fig. 138), where it may be seen that the doup is simply drawn

through the eye of the mail, and not connected with it in any way. It is only held in this position by the warp thread passing through it, and whenever the thread breaks the doup falls out of the mail. This is a trouble to the weaver, at least till she gets accustomed to it, and mails, as shown at No. 2, have been made to hold up the doup. The remedy here is often worse than the evil. The mails wear the doups, particularly if the springs draw them tight down on the eyes of the mails; and besides, they have the disadvantage that the slip heald has to be built in them after the harness is mounted, whereas with the open mails the slips can be procured anywhere quite independent of the harness. The slip heald must be set so that when the harness is down the yarn will not be drawn through the eyes of the mails by the doup sinking too low. This may be guarded against by adjusting the bridles at each side, between the slip shaft and the cumber board. The loops of the doups should pass about $\frac{1}{4}$ in. through the eyes of the mails when at the lowest or bottom position, and the front mails being about $\frac{1}{4}$ in. lower than the others allows the loops of the doups to be just bearing lightly on the warp, all being held up straight. The slackening bar must be arranged to work in time with the doup standards, and should not slacken the yarn too much nor too little, just keeping it at a uniform tension. The great point with tender or weak yarn is to reduce all friction to a minimum, no matter by what it is caused, and if this is done the yarn and doups, if they are of a fair quality to begin with, should both work well; but a very slight difference in setting the doup may make a great deal of difference in the working of it. A doup that may be cut to pieces in working 20 yards of cloth might work 400 or 500 yards with so little alteration as not to be noticeable to those not accustomed to the work. The slackening bar must not rise so high as to raise the yarn that is above it, nor must it sink so low as to press the whip down on the back harness board, and it must be so regulated that within these limits it will give the proper amount of slackening, and prevent the whip warp from getting tight and drawing up the small back harness.

Worsted makes the best weaving doups for strong work, but for lighter work cotton is mostly used, being finer and cheaper. Some-

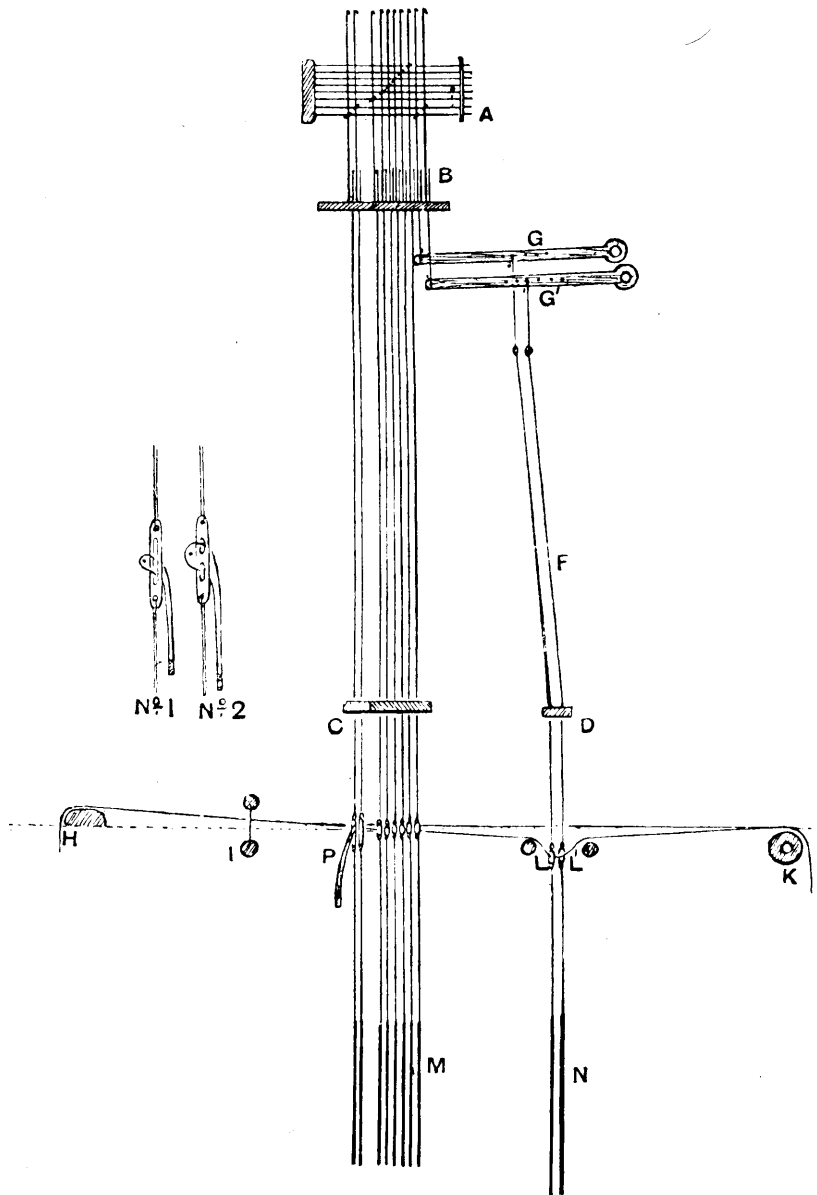

FIG. 138

times polished linen yarn is used and makes a very smooth doup, but does not give the wear.

Small metallic rings are sometimes used on the loops of the doups, and the warp drawn through these rings; this suits for yarn with much fibre on it, as it keeps the fibre from getting twisted into the doups, but the rings cut the doups faster than ordinary yarn working in them would.

Instead of a slip heald in front, doups with a lingo on each have been used, with the mails for the standards as shown at No. 2, Fig. 138, so that the doups cannot fall out of them, and the yarn when drawn up by the back harness in shedding raises the doups and lingoos up with it. The weight of the lingoos must be such as will suit the strength of the warp to be used—not too heavy for it to lift nor too light, so that in the cross shed the doups would be drawn through the mails. These doups being separate, are easily built in the harness and very easily repaired by the weaver when they break, but they break too frequently. It is, of course, only for a strong warp that this method of working is suitable, and even for it, although it works very well, the principle is not good.

The gauze harness which will probably be most frequently met with, at least in the cotton trade, is shown in Fig. 138. It is an older harness than that described, having been patented in Macclesfield in 1876 in a somewhat different form. The difference between this and the preceding chiefly consists in the method adopted for slackening the yarn, and the jacquard may also be specially built to suit for this. In setting this loom the harness and mails are tied up and levelled as before, but when working the back rail is kept down, as it usually is for gauze work, say about $\frac{1}{2}$ in. lower than the eyes of the mails. Each whip thread has its own slackener, the slackening apparatus consisting of a harness wrought either by the same jacquard that works the figure, or by an extra one, when much pattern is required.

The connections of the needles with the hooks are shown at A, the two bottom needles being connected with the two front and two back hooks, the former for working the gauze and the latter for working the slackeners. This harness is intended for a 1-round 3-gauze, and is

mounted on a 10-row machine with an 8-row cylinder on it. It is not necessary that the back harness for slackening should be raised so high as the figuring harness is, and for this reason, as well as that it makes the harness more direct and avoids friction, it is tied to two sets of levers as shown at G and G¹; they are made of brass and are fastened on two rods, one about 4 in. above the other, so as not to come into contact with each other when rising or falling. The points of the levers are fastened to the two back rows of hooks as shown, and the harness is tied to wire hooks on these levers; F is the neck of the harness, D the cumber board, and N the lingoos, which are much heavier than those used for the figuring harness, from 6 to 10 per pound being the weights frequently used, according to the class or weight of the work.

The mails used on the back harness are similar to those used for the doups—that is, such as are shown at No. 1 (Fig. 138); but if these cut with the warp sawing through them, glass mails should be used. L L¹ are two rods or bars which support the warp that is drawn down between them by the slackening harness. The closer these bars are set together the greater will be the amount of slackening given to the warp when the harness is drawn; therefore these bars should be made to slide either way so that the desired slackness is obtained by setting them. About 3 in. to 4 in. apart is a good working width; the tops of the bars should be about 1 in. lower than the mails in the figuring harness, and the tops of the eyes of the mails in the back harness should be 1 in. or $1\frac{1}{4}$ in. lower than the rods.

Another method of arranging the needles in a jacquard for a gauze mounting is shown in Fig. 139, which is, perhaps, more convenient for the designer, as will afterwards be seen. In this harness there are 10 rows of hooks, the same as before—6 for the figuring harness and 2 for the doup standards. The doup standards are here on the hooks connected with the fourth and eighth needles, and come after the threads that the whip in them twists round, and fall in this position on the design paper, instead of both being at the end of a design—that is, on the seventh and eighth checks. For any order of twisting, the arrangement of the hooks and needles might be made to suit on the same principle.

It will be seen that in the leno jacquard, shown in Fig. 138, a number of levers and attachments are required to work the slackening harness. In order to simplify this, Messrs. Devoge & Co. have brought

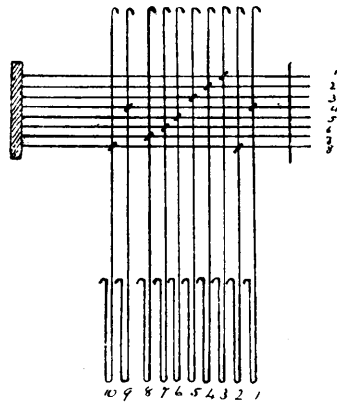

FIG. 139

out a leno jacquard with which none of these levers, &c., are required, the slackening harness being tied to the two back rows of hooks in the machine. These two rows of hooks are lifted by a separate griffe, the lift of which is much less than that for working the body hooks of the machine, and which can be varied to suit the amount of slackening required. This machine is shown in Fig. 140, a view of the motion for raising the griffes of both back and body harness being given in

Fig. 140 A. *c d* (Fig. 140.A) is the link connection between the bar of the griffe *a a* and the top lever *L* (Fig. 140), somewhat similar to what is used for an ordinary jacquard. To raise the small griffe at the back, it will be seen that there is a cross lever *e* from the links *d, c* to its fulcrum *h* on a bracket *g* attached to the top of the machine. The small or back griffe *b* is connected to this lever by the link *f*. The amount of lift given to the small griffe in proportion to that given to the large one will be as the length of the lever from the stud in *h* to that in *f* is to its length from the stud in *h* to that in *d*. The farther the fulcrum is pushed back in the slot in which it is fastened, the more the back griffe will be raised, the link *f* being always vertical. The back griffe is arranged to commence lifting slightly in advance of the front one, in order to lessen the strain on the doups. The needles are connected with the back and front hooks in this machine similarly to those in Fig. 138.

The draft of a gauze in the harness is just the same as regards the doups as for shaft work; the crossing may be made from left to right, or the reverse, but the pattern must be made to suit. Some mount the harnesses and paint the patterns from right to left. About Brad-

ford this appears to be the usual method, and it does not matter provided the mounting, drawing and designing be kept in accord; but here we shall keep to the same principle as is recognised all through—viz. mounting and designing from left to right, which is the correct method so far as drawing is concerned, and equally convenient in other respects.

To design a pattern for gauze: if it is to be a simple geometrical

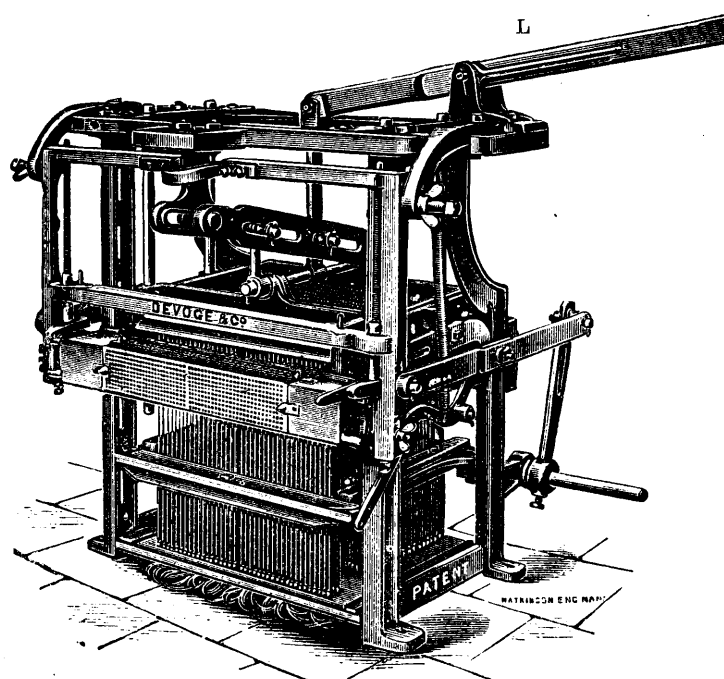

FIG. 140

pattern it may be put direct on the design paper; but if to be a figured pattern, a sketch should be prepared for it in the same manner as for ordinary figured patterns, whether for dress goods, curtains, or any other material. Any desired figuring can be made, providing sufficient space be left between the figures to admit of the open work being made. The figuring should be treated as the ornamentation of a plain or short twill ground figure, which is woven on a gauze ground;

the figure may be entirely plain or twill upon a gauze ground, in which case it must be sufficiently plain and solid to be effective, or it may be treated as damask figuring on ornamental patches of plain or twill on a gauze ground; or, again, the gauze may form the figure and the ground be plain or twill. Any variety may be made that ingenuity can suggest, and figuring with extra warp or weft may also be adopted if desired. When about to put the pattern on design paper, it may be observed that out of the 8 rows of needles in the machine only 6

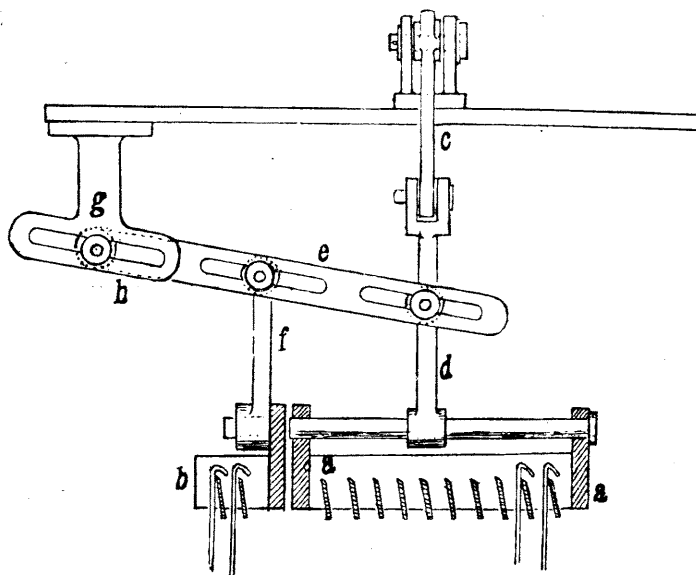

FIG. 140 A

are used for figuring, the other 2 being employed for gauzing; therefore, some means must be devised for getting the pattern on the paper so as to suit this. The simplest plan is that adopted in America—viz. instead of using two rows of hooks along the jacquard for the doup standards, to leave as many hooks at the first of the machine as will correspond with the number of doup standards required for one repeat of the pattern. Suppose for the same ties as those given—100 hooks for the doups and 300 for the figure—then the cords from the first or last 100 hooks would be taken down through the two front

rows of the cumber board, and those from the 300 hooks would make up the body of the harness. When mounting in this way, the jacquard would be better turned with the cards hanging over the side of the loom, as for the 'London tie.' This method of mounting enables the pattern to be designed for 300 hooks and painted on the design paper independently of the gauze, which can be filled in afterwards.

Fig. 141 is an example of designing in this manner, using 6 rows of hooks, to suit the gauze. The pattern is put on the rows of designs numbered 4, 5, 6, 7, and 8. No. 3 is for the selvage, and the working of the doups is on Nos. 1 and 2. This is for a 1 round 2

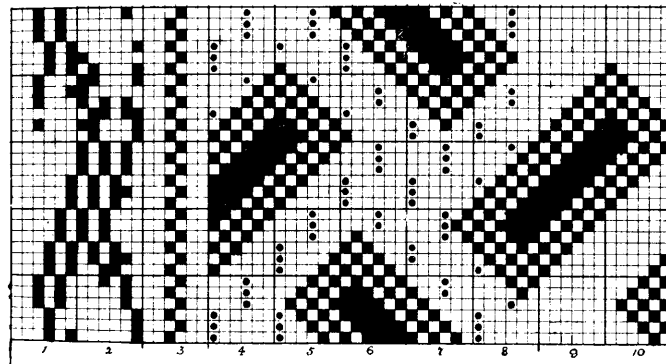

FIG. 141

gauze, 6 checks, or 2 splitfuls of gauze to the design; there would be 10 doups required for the 5 designs in the repeat of the pattern, and for these 10 checks are used of designs Nos. 1 and 2. The rising of the back leash of the harness to form the crossing is shown by the dots marked on the design, and as gauze is formed by raising this leash and the doup alternately, it is only necessary to take each line of the design paper for the doups, and, following up the markings for the back leashes, fill in for the doups to rise when the back leash is sunk for the gauze, taking care to keep clear of the figuring. In making gauze the doup should always rise immediately after the figuring ends, to form the first crossing, and it should also be up immediately before

the next portion of the figuring begins, so that in an irregular figured pattern the gauze might frequently require to be broken to effect this, as may be seen in Fig. 141. Take the first upright line of the pattern, design No. 4: the back leash is raised for three, then the doup for three, and the figure follows. Passing on to the tenth line it will be seen that the doup rises for three after the figure, and is also up for three before the next figure begins; but, passing on to designs 7 and 8, it will be seen that the risings of the doup and back leash would not fall in regularly in threes against the figure, as it would be better if they did, and therefore the gauze is broken so as to fall in; but in small patterns of this description, when it is of importance to keep the out-

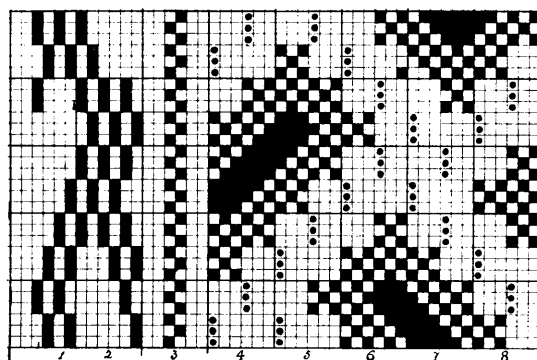

FIG. 142

line of the figure as regular as possible, this can and should be remedied; instead of the outline of the figure running diagonally on the design paper in steps of one check, it should go in steps of as many checks as there are threads to the twist of the gauze in the warp and shots in each twist in the weft. This is shown in Fig. 142, where all the twisting falls in regularly with the figure. This may to a great extent be carried out with irregular figures by the designer exercising a little judgment, and when filling in the gauze make up the plain edging of the figuring to fall in with it—that is, only to break the gauze where there is room to do it effectively, and where there is not, a few dots can be added to the plain. If Figs. 141 and

142 be compared, it may be seen how this could be done : examining designs 4 and 8 above the figures, the latter below as well ; but Fig. 142 shows the proper method of treating these small geometrical figures. Another point to be observed is whether all the doup leashes are to be raised together to form the gauze, or whether it is to be formed by raising every alternate doup leash and every alternate back leash, as is done in these figures. The latter method is preferable for working, as it makes an even tension on every shed, whereas if one shed is a full cross shed formed by the doups, and the reverse of this an open shed with no crossing, the cross shed will be the tighter, and produce a certain amount of plucking, with a tendency to shire in some patterns ; but in case of working dices or any pattern where the top and bottom of the figure extend some distance straight across the design paper, it would be impossible for the first shed of the gauze to be formed by the doup if only every alternate doup leash was raised. Some judgment must therefore be exercised in these matters, and the best effect obtained that will suit circumstances.

Now to put the patterns on design paper to suit the harness when the two front rows of the jacquard are used to work the doups, as in Fig. 138, also when any other rows are used, as in Fig. 139 : the simplest way to do this—at least, for those not well accustomed to the work—is to design them on 6-row paper, as Fig. 142, and afterwards transfer them to 8-row paper, leaving the lines for the doups empty, the doup lines being afterwards filled in, as in Figs. 143 and 144. Fig. 144 has the advantage that each splitful of gauze stands alone, whereas when filling in the markings for the doups in Fig. 144, two splitfuls stand together ; but a little practice makes one method as simple as the other. The dots represent the markings for the doups, and the shaded squares those for raising the back leashes to form the open shed of the gauze. The transferring of the designs from one sheet of design paper to another is, of course, a matter of trouble and expense, and may be avoided if an experienced card-cutter is to cut the cards. The design need not be transferred, but have the marks for raising the doups put on the same lines of the design paper as those for raising the back leashes for the open shed. This is shown in Fig. 145, the

shaded squares being the same as in Figs. 143 and 144 ; but the dots, instead of being put on lines left for them, as in these figures, are put

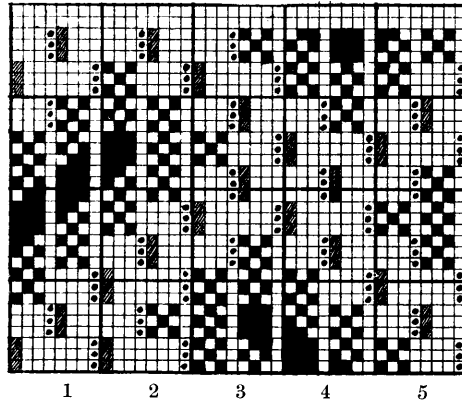

FIG. 143

on the same lines as the shaded squares, and the card-cutter sees to their being cut on the correct lines, as in Figs. 143 and 144. In designing, different colours would be used. The shaded square should

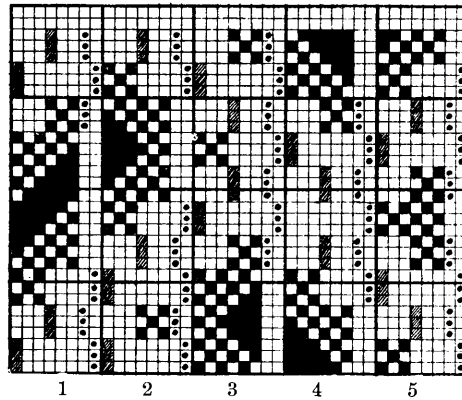

FIG. 144

be the same colour as the figure, as they are to be cut for the lines they are on, but the dots should be of a different colour, to be cut for

a different line of the card from that on which they are placed on the design—the dot on the first check of a design being the seventh hole in a row of the card, and that on the third check of a design being the last hole of a row on the card.

Fig. 146 shows a portion of an ornamental pattern as it would be designed for a gauze ground of two threads of warp twisting round two = 4 in the split and 4 picks into each crossing of the gauze. This would require a 10 - row machine, eight rows for the figuring harness and two rows for the doup standards. When two threads are twisting round two, it is not necessary to have a doup for each, though it may be desirable ; but it suits very well to have both threads drawn through the same doup. It will be necessary to have a stronger doup in this case, but if the warp is very

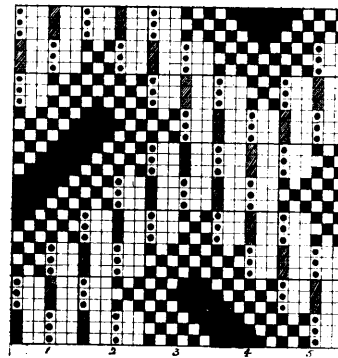

FIG. 145

light it would have so much more to do in drawing up the heavy doup than if each thread was drawn through a very light doup that the latter had better be adopted ; otherwise a stronger doup, with both threads through one, is simpler. On the pattern, the doups are raised by the dots, which must be cut on the proper line of the card, as before ; both lines are dotted as if each thread had its own doup, but only the front dots of each pair are necessary. The shaded squares are for raising the crossing threads with the leashes for the open shed of the gauze. In this pattern it is necessary that the outline of the figure should go in steps of four warp ways, as there are four threads to the twist ; but it is not necessary that it should go in steps of four weft ways. A better outline can be given to the figure by not adhering to this, though the perforations in the gauze will be to some extent sacrificed by being irregular ; but this would be so in any case in order to raise the doup standard after the figure when the doups and leashes are gauzing alternately ; they might be regularly started at one side of the figure, but

this would probably make them more irregular at the other side. By following round the edges of this figure it will be seen that by a little care no blemish of any consequence need be left, though it will not be so perfect as when calculated to fall in as Fig. 145.

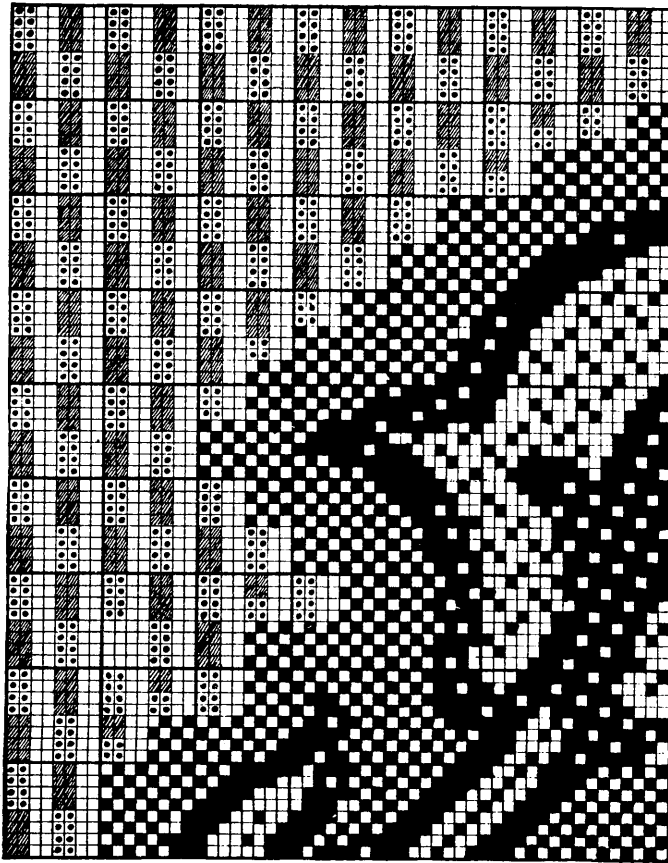

FIG. 146

Any variety of simple gauze texture may be used, as well as the plain and honeycomb gauze, but unless there is plenty of space and the figures are plain and large, no very intricate crossings should be attempted, unless for stripes, as they would probably mar the outline of the figure; but if not, they may be used where suitable.

Another important point in designing for gauze is that if the texture of the solid cloth is loose and that of the gauze pretty firmly twisted, the take-up of the warp may be very different when weaving. To avoid this the gauze and figure should be well intermixed, and not be in too great quantities in any one part—in fact, the gauze and plain should be constantly interchanging, and when the pattern is such that this cannot be, the textures must be regulated so that there will be about an equal quantity of warp taken up for each. A little practice will soon show this.

Nothing has been said about the description of jacquard used for working gauze, but the same principle holds good as for working with shafts. A gauze shed is taken to be a plain jacquard lift—that is, the shed formed by the single-lift jacquard raises the yarn and lets it down again before beginning to raise the following shed. This enables the doup and doup yarn to fall into their places before being drawn away to form a following shed. At the same time, we are not limited to a single-lift jacquard. If you have a double-lift jacquard, and want to work a small piece of gauze, do so; but do it correctly, or, in other words, take means to make a good job of it. Before explaining how to do this, it will be well to show where the difficulty exists. In a double-acting machine one griffe is rising when the other is falling, and in plain gauze the doup standard and leash carrying the crossing thread are raised alternately, one shot being thrown into the shed formed by each. Therefore, the same thread is up for every shot, and the thread round which it twists is always down. Now, when one griffe has raised the doup standard and the next one raises the leashes carrying the same threads, both will pass in the centre of the shed, and, as shown in Fig. 147, the crossing thread will be dragging up the lying thread from the position shown by the under dotted line, thereby causing considerable friction on the yarn, which must be detrimental to a fine or weak warp, and is inclined to drag the doup through the eyes of their standards; but as the harness in coming to the centre slackens the warp threads, and also as the slackener begins to act when the harness begins to rise, the threads will be further slackened in those sheds where the doups follow the back leashes, and this reduces the friction. It may, however, be

entirely avoided by raising the lying threads to the mid position to meet the descending griffe, and then let down with it. A simple method of doing this is to have the leashes carrying the lying threads through a separate slip of cumber board at the back, and knots on them above it, so that when it is raised all the lying threads will be drawn up with it.

The cumber board can be raised by a cam, or in any other suitable way. (See *Journal Weaving for Scotch Carpets*.)

These leashes might also be raised by means of a shaft through

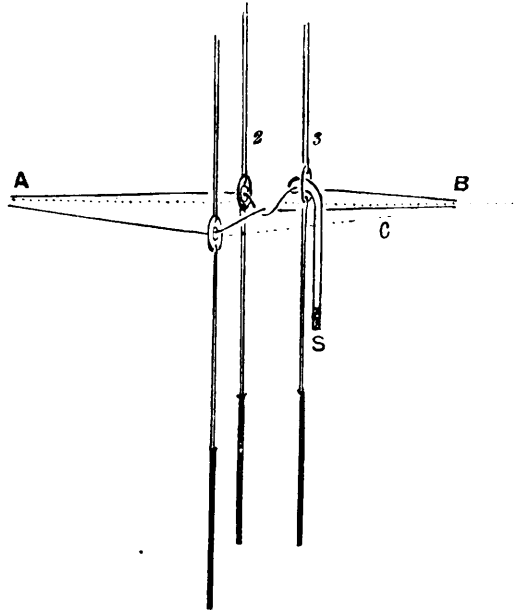

FIG. 147

loops in them, or with bars under the jacquard hooks, in the same way as is done in twilling harnesses (which see), but with a special motion to raise and lower them. In Fig. 147, the dotted line A, B shows the middle position or centre of the traverse of the yarn in shedding.

Although this is the proper means to adopt to work gauze satisfactorily with a double-acting jacquard, or with any double-acting shedding motion, it may be that small portions of gauze, such as a few stripes up a web, are wanted without the trouble of making any special

arrangements for it. Good strong twist cotton yarn will work very well, if nicely tempered, in a double-acting machine. The slackeners can be arranged by leaving a few hooks apart to work them with, and cords tied to these hooks and let down at the back, in the same manner as in the gauze harness (Fig. 138), which will do very well. When three or more shots are thrown into each shed of the gauze—that is, between the crossings—there will be much less friction than when the crossing takes place at each shot, as it is only at the crossing the friction takes place.

One source of annoyance in working gauze is the wear on the doups, which requires them to be changed frequently and adds cost to the production. It has often been attempted to work the gauze by other means, and for some classes of work this has proved successful. One of the best arrangements, and one that is largely used, is the gauze reed, which is almost entirely adopted about Glasgow for weaving leno curtains in the power loom; it is also employed for other classes of work, but is limited in its use. It will not supply the place of a gauze harness.

THE GAUZE REED.

This is principally used for working leno curtains or Madras muslins in power looms. The texture of these fabrics is a plain gauze ground, the figure being formed by one or more colours of thick soft weft, thrown in and bound for the figure, but flushed or floated over the ground, to be cut off afterwards. The reed is wrought in conjunction with a harness, the reed forming the ground of the fabric and the harness the figuring. The harness is mounted in the same way as a half-harness, or for half the warp, and the reed does the work of the doups. The gauze reed will suit for gauze up to 55 threads per inch in the reed, but is more used for fabrics ranging from 30 to 50 threads per inch. A portion of the reed is given in Fig. 148, in which it will be seen that it consists of the usual dents set in ribs, and a set of half-dents, perforated at the points which are set into the lower rib of the reed behind the others, and lie about half-way through the splits in a

slightly slanting position. The gauze reed works behind the slay and in front of the harness. It should be about $\frac{1}{2}$ in. behind the slay when the cranks are at the back centre, so as to leave sufficient room for clearance between them.

A good method of working the reed is shown in Fig. 149, which is a back view. *A* is a rocking shaft supported by brackets, as *a*, on the top rail of the loom; *B* is a lever projecting towards the front of the loom, and the rod *b* from it supports one end of the reed; *c* is another lever on the shaft *A*, projecting backwards, and the rod *D* connects it with the tappet treadles, so that when the treadle is pressed down the reed rises; about $3\frac{1}{2}$ in. is the usual height for it to rise. *F* is the upper rib of the gauze reed, and *F'* the lower one. *G* is the yoke of the reed. On the yoke is fastened a bar *P P*, connected with the strap which passes round the top rib of the reed. *I I* are two projections on the bar *P P*, through which the slide rod *E E'* passes and is fastened at the top to a bracket *c* on the top of the loom, and at the bottom it fits into a socket or stand *N* fixed to the ground; the reed slides up and down on this rod. *H* is a tube round the slide rod between the projections *I I*, and is about $\frac{1}{2}$ in. shorter than the distance between them; to the bottom of this tube is fixed the support *H'* for the dipping rod *K*, which, when the yarn under it is very tight, can yield $\frac{1}{2}$ in., along with the tube *H*. The reed is not positive in falling, but when raised by the tappet it falls by its own weight and that of the weight-box *L*, which slides on the rod *E E'*. The weight-box is fastened by a rod *M* to the crank on the bar which supports the dipping rod, and weights it as well as the reed. Small weights, as *R*, about $\frac{1}{4}$ lb. weight, can be placed in the weight-box till as much weight as is required is put on. Fig. 151 gives a view of the gauze reed mounting, with the gauze or cross-shed open. Every alternate thread of the warp is drawn into one of the gauze dents, and every other one into the harness, as shown. The harness is levelled 2 in. or $2\frac{1}{2}$ in. below the level of the breast beam; or, having the slay levelled with the race $\frac{1}{2}$ in. below the breast beam when the cranks are at the top centre, push back the slay till the cranks are at the back centre, and place a straight-edge across the race, and the under edge of the

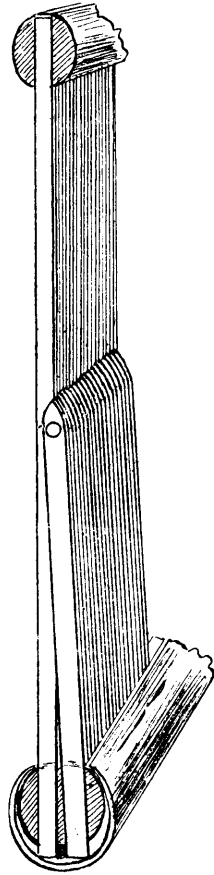

FIG. 148

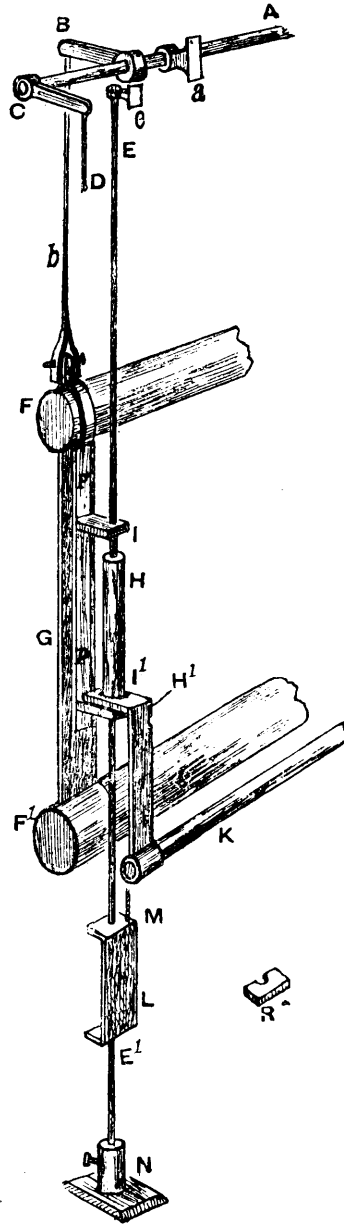

FIG. 149

straight-edge where it passes the front row of the harness will give the height for the eyes of the mails. The back shell E should be set $\frac{1}{2}$ in. below the level of the breast beam, and should be made to vibrate with a tappet, which should lower it when the gauze shed is opened, and keep it raised for the figuring shots. A shows the position of the weaver's reed, B is the gauze reed, C the dipping rod, D the heck or ravel which is on the harness under the harness reed or cumber board F; the ravel should be about 6 in. above the yarn and 3 in. below the cumber board, making the latter 9 in. or 10 in. above the yarn. The ravel is like a small harness reed with only one rib on it, which is

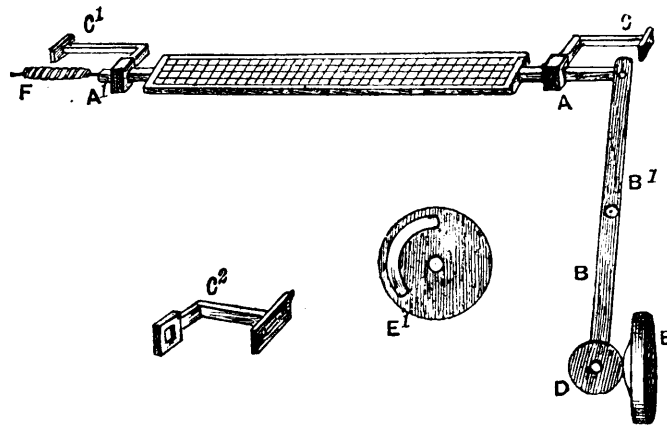

FIG. 150

placed behind the harness, being covered with an iron tube to strengthen it; in front a flat iron rod is fastened above the ends of the dents and serves as the second rib. Three wires are stretched along the ravel to keep the harness steady, in the same way that they are stretched along a harness reed, but three are sufficient, instead of having one for each row of harness. The ravel is shown in full in Fig. 150; it is about $1\frac{1}{2}$ in. deep (or across it), and the cumber board 3 in. deep; it is for the purpose of drawing the yarn in the harness to either side, so that when the gauze reed is rising the half dents may pass to the right and left of the threads in the harness alternately; it is this which gives the gauze twist. Two bars A A¹ (Fig. 150) extend from the ends of the

frame of the heck ; these slide in brackets $c c^1$ fastened to the sides of the loom. The lateral motion is given to it by a lever $B B^1$ with its fulcrum at B^1 ; this lever has a bowl D on its lower end, which is acted on by a wheel E driven at the proper speed to suit the shedding. E^1 is a face view of this wheel, which has a projection on it for shifting the lever.

Sometimes the motion is imparted to the lever so as to shift the ravel just when it is required—that is, before the gauze reed has risen to form the shed ; and sometimes the ravel is shifted a part of the way at each shot of figuring, and has completed its traverse before the gauze reed has risen ; this latter makes a more gradual pressure on the harness, and avoids any sudden plucking. When the wheel E acts upon the lever the ravel is drawn to the right, and when released the spring F , fastened from the side of the loom to the end of the ravel, draws it back again. The traverse of the ravel should be about $\frac{3}{4}$ in. c^2 is a separate view of the brackets c and c^1 .

Sometimes the heck is on the yarn between the reed and the harness, instead of being on the harness ; in this case there must be about 8 in. between the reed and the harness, and the heck or ravel rests about half-way between them. The harness is wrought with a double-lift machine and three tappets. One tappet which is much like a plain wyper tappet, but with less dwell on it, acts on one of the treadles, which is connected by a rod and lever to one of the griffes ; this raises the flowering shed, the lift being about $3\frac{1}{2}$ in., and the flowering shot is thrown in as in ordinary work, the sheds being close when the cranks are at the top centre or a little over it. As soon as this shot is thrown in, when the cranks are a little over the back centre, the second griffe is raised by another tappet. As this takes place before the cylinder is in against the needles, all the yarn in the harness is raised ; the reason for raising it is to get all the harness yarn clear of the half dents of the reed, so that it can be shifted over them by the ravel. The gauze reed is raised by the third tappet ; it begins to rise shortly after the second griffe, or when the cranks are a little past the top centre during the same revolution. The yarn raised by the first griffe begins to fall at the same time that the reed begins to rise ;

the second griffe raises the bottom yarn till it meets the top yarn of the first shed descending, at which time the ravel should be fully shifted, and the points of the half dents rising should be $\frac{3}{4}$ in. below the harness yarn. As the harness falls and the reed rises, the yarn in the former will pass down at the opposite sides of the half-dents to which it was before being raised; a ground shot is then thrown in (this is the second ground shot), and the reed descends, taking the yarn in it down level with that in the harness. The harness is again raised as before for the next flowering shot.

When the reed is raised to form the shed for the ground shot no card is required to pass over the cylinder of the jacquard, and to prevent one passing the sneck or shears is raised for this shot, so that the cylinder is not turned. The reed must be raised in time to have the shed open for the passage of the shuttle, but keeping it a little late requires less lift to be given to the second shed which is being raised to get the bottom yarn clear of the half dents of the reed. The above description is intended for weaving fabrics with one cover, or one colour of flowering shot, as when the pattern is in white or a single colour, as it often is; but when two or more colours of figuring weft are used, the flowering sheds might be opened with one griffe working the machine single-acting, and constructing and timing the tappets to suit. One tappet would then open two or more sheds for the flowering; the second and third tappets would act on the bottom yarn and reed as before. It is, however, usual to work the machine double-acting, and to construct the tappets to raise the griffes alternately for two covers. No. 1 tappet would raise one griffe, No. 2 tappet would raise the other griffe; then a small wing on No. 1 tappet would lift the bottom yarn, and No. 3 tappet would raise the reed, the sneck being lifted at the last beat of the cylinder to prevent it from turning. For three or more covers the tappets would require to be arranged to suit in a similar manner. Fig. 151 A is a front view of the position of the yarn in the reed when the flowering shed is drawn. Only a portion of the harness would be raised for each shot, as, say, the threads 1, 1, the remainder 2, 2, being sunk. After the flowering shots are thrown in, the bottom yarn in the harness 2, 2 has to be shifted to the other

side of the half dents for the gauze shed. It is therefore raised up to meet the threads 1, 1 coming down. All are then shifted together, and when the reed is raised the position of the harness yarn is shown at the crosses; 0000 shows the position it was in at the previous

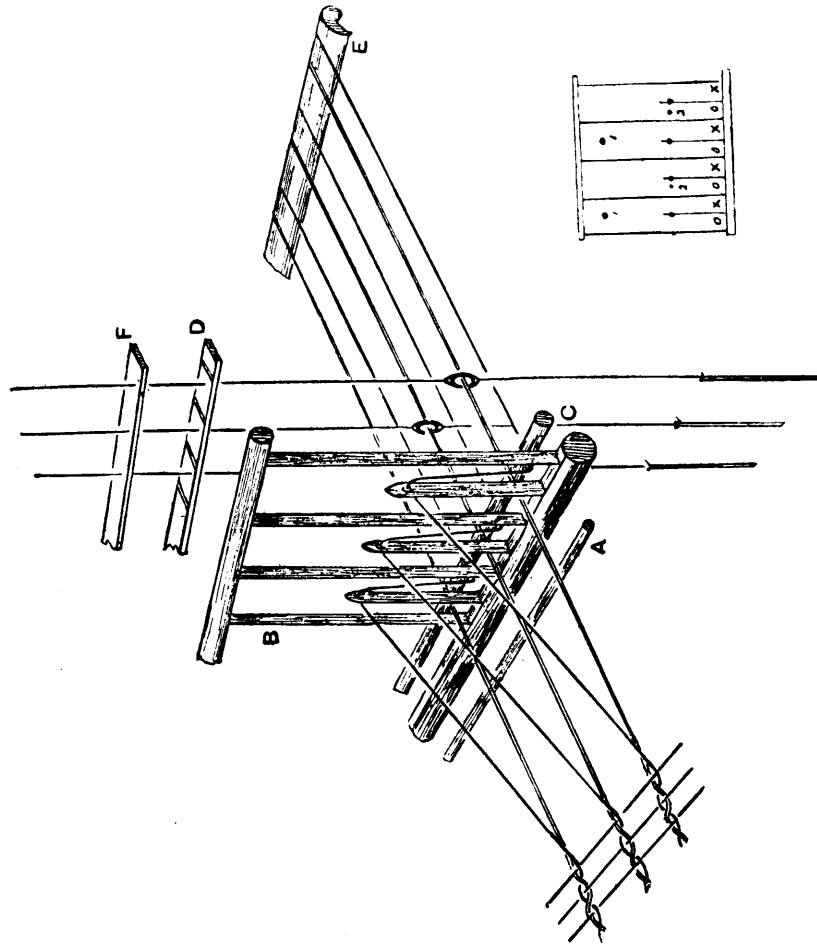

FIG. 151 A

FIG. 151

ground shot. The dots on the half dents show the position of the yarn in them in relation to that in the harness 2, 2 when the reed is at rest, the yarn in both reed and harness being on a level. The reed could be wrought turned upside down with a harness, but all the loose

flowering weft would require to be below. In this case there is no necessity for getting the under shed clear of the gauze dents for changing it with the ravel to form the ground shed ; but this is an objectionable method of working, particularly with a light pattern, on account of the heavy shed that has to be raised. If the flushed yarn was thrown to the top and the reed turned upside down, the only way to work the heck would be on the harness below the mails, which would require it to be as deep as a reed or cumber board, in order to let the lingoes fall, and this would not answer very well.

CHAPTER VIII

DOUBLE CLOTH

DOUBLE CLOTH AND QUILTING HARNESES

A VERY great variety of cloths come under the heading of double cloth ; in fact, almost every description of coloured cloth figured in the loom, excepting coloured damasks and the commoner descriptions of dress goods, as well as many uncoloured fabrics, are generally woven more or less on this principle. Quiltings are mostly made on the double-cloth principle, and have nothing to specially distinguish them, except that some makes of cloth appear to be more suitable for goods of this description, though frequently other fabrics of a much more costly nature are woven in the same way ; as, for instance, matelasses may be made in the richest silk and worsted for jackets, as well as in coarse cotton for quilts. One of the largest sections of double cloth is carpetings, but these will be described in a separate section.

For figuring double cloths the same principles of the structure of the cloth, &c., hold good as when weaving them plain, or in fancy texture. Any suitable pattern can be put upon any description of double cloth with a full harness mounting mounted in the ordinary manner ; but the pattern must be spread over the design paper to suit the description of cloth to be made, which often necessitates its being in a very distorted form, unless it can be arranged in different colours so that the card-cutter can cut several cards from each line of the design paper. For instance, if three colours are required to form one complete weft line, then three lines of the design paper would be taken up with these, unless the colours could be arranged that the three cards could be cut from the one line, as frequently can be done ; and the

same for the warp when there is a face and back warp, or several colours to be brought up for one warp line. When there are two warp threads, one for the face and one for the back, two hooks of the jacquard are required to weave them, and two lines on the design paper are also required, unless two colours are painted on one line to guide the card-cutter in cutting the cards.

It is a great saving of work to the designer when the pattern has not to be spread over the paper so as to give each line separately, as doing so generally puts the pattern so much out of shape that it requires first to be designed square, or of the proper dimensions, on suitable design paper, and afterwards transferred to the working design for the card-cutter. When goods are being largely made this can often be avoided by special mechanism or mounting, to act instead of the cards, it being then worth the trouble of having a specially prepared mounting, and it is in these cases where double-cloth mountings are used. Perhaps the simplest class of the double-cloth range, though not really a double cloth, is figuring with extra weft. The figuring weft may be thrown in as a spotting intermittently, or may be every alternate shot, a ground shot following each figure shot.

Suppose the cloth to be a plain ground and a twill figure, and that 500 cards would be required to weave the figure if it were plain damask; it is then evident that 1,000 cards would be required if every alternate shot is ground, and the others for figure, and that the 500 plain cards for the ground would be two cards repeated 250 times. Now, instead of this, if we use a double-cylinder jacquard, and put the figuring cards on one side and four plain cards on the other side, we can save 496 cards, as the four cards on the cylinder will work the plain at every alternate shot. Or suppose a single-cylinder machine to be used, then shafts might be put through loops in the harness; or the cumber board might be made in sections, with knots on the harness twines above it, so that in either case the harness could be raised in rows to form plain cloth.

The plain shed could be formed with a tappet and levers, as in journal weaving, and the griffe would only be raised for every figuring shot. Plain cloth might also be wrought with a twilling motion on the machine, such as is used on twilling jacquards. A pair of pressure

heddles in front of the harness is a common method of accomplishing this in the hand loom. The harness is drawn for one shot, then let down, and one of the pressure heddles sunk and the other raised for the second shot. For the third shot the harness is again drawn, and for the fourth shot the plain shed is crossed with the heddles. A twill or any figure may be used, as well as a plain ground.

The next step in double cloth is perhaps double-weft-faced cloth—that is, when the surface of the cloth on both sides is formed by weft, the warp lying in the centre, and merely acting as binders to bind the two wefts together. The warp may occasionally be brought to the surface to give additional effect, or to add a third colour; or the body of the weft may be kept on one side, the warp forming the ground on the other side, with a weft figure on it, producing a one-sided cloth.

This class of work is best wrought in a pick-and-pick loom; but a check loom—that is, one with extra boxes at one side only—can frequently be used, and gives much less trouble. For a check loom two fine shots may be used as one, having each pair of cards alike, except at the selvage, and throwing two shots into each shed. Of course this takes twice the number of picks and cards (unless two picks be given to each card), but in some cases, as for borders, this may be an advantage in comparison with working pick-and-pick. Often two succeeding cards of the pattern for the same colour are made to follow each other, as may be found in tapestries, &c., and the weft knocks up into its place without showing any defect; but in a heavy cloth, with a thick or stiff warp, the weft could not be knocked close together on this principle. With a fine binding, warp of cotton and a thicker weft of woollen or worsted, there is no difficulty in this working.

For double-weft-faced patterns the simplest method of designing is to paint the pattern as if for plain damask, and then cut two cards for each line of the design paper, one card being cut exactly the reverse of the other; that is, the cutter cuts the painted squares for one card and the ground squares for the next card. In lacing these two cards are kept together, a ground and a flowering card coming alternately. There is, however, an objection to this method of binding the texture of the cloth, though in many cases it works very well. The objection is that

the warp has to be brought from the face of one side through to the face of the other side for the succeeding shot to form the binding, instead of being brought from the centre only to the face as it should be.

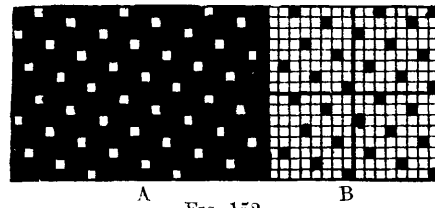

FIG. 152

Fig. 152 shows a portion of a stripe pattern designed to produce 8-end twilled stripes. If a black and a white weft are used pick-and-pick, the white pick coming first, A would be a solid black stripe and B a solid white stripe, or the appearance would be as on the design paper, but much reduced in size. On the under side of the cloth the colours would be reversed.

The first card would be cut as the painting, cutting black, and the second card would be exactly the reverse of this, cutting the white or ground squares on the same line of the design paper. The texture formed on the cloth by these cards is shown in Fig. 153,

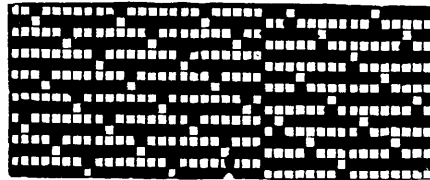

FIG. 153

each line of the design paper representing one card.

The correct method of binding is shown in Fig. 154, where it will be observed that the binding of two succeeding weft shots does not fall on the same warp thread, and that the binding dot will be covered by the floats of the preceding and succeeding weft shots when the weft is knocked up close.

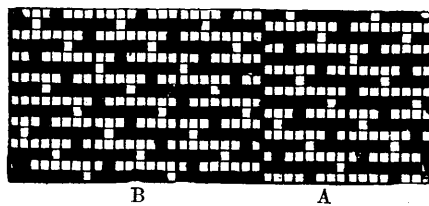

FIG. 154

There are other squares on which the binding dots might be placed as well as those in Fig. 154, one check to the left of where they are being frequently used. A stripe pattern, as Fig. 152, can be put upon design paper with each line representing two

cards, and be twilled to give the texture in Fig. 154, as is shown in Fig. 155.

When cutting this the cutter cuts the shaded squares and black dots for the first card, and for the second card he cuts white and crossed squares on the stripe B, and the solid black squares on the stripe A, which it will be seen is exactly the same as cutting the black for the first two lines of Fig. 154.

When painting the design the shaded squares may be red, the black ones black, the black dots yellow or white, and the crosses green; or any other convenient colours may be adopted. It will be observed that in Figs. 152 and 155, where the raised and sunk twills come together at the junction of the two stripes, there are no binding dots on the two threads lying beside each other. It is not necessary to have any bind-

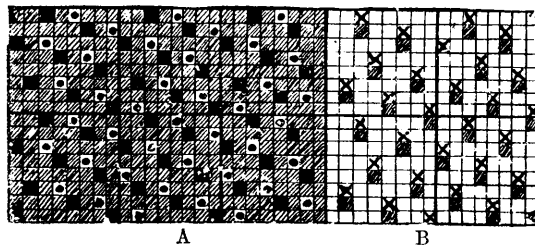

FIG. 155

ing for these threads, as the two wefts crossing bind them sufficiently. Any desired figure may be woven on cloth on this principle, which is a very convenient one, as the colours can be so readily changed, and three or more colours may be used as well as two; but in this case there is generally a right and a wrong side to the cloth, the body of the wefts being at the back and each colour brought through to the face to form the figure. Instead of the body of the weft, or that portion not required for the figure, being at the back of the cloth, it may be in the centre of the warp, and an equally good face made on both sides of the cloth; but this requires more wefting, makes a thicker and harder cloth, and is more expensive and more troublesome to weave.

Warp figuring may be done in exactly the same way as described for weft figuring, and the pattern turned sideways shows how it would

be for warp ; the only difference in the work all through is to treat the warp as explained for weft. Of course, in the designing and card-cutting, cutting two cards, one the reverse of the other, from a design painted as if for a damask, would not fall in, but the designs that are wrought fully out on the design paper would be all right. A contrac-

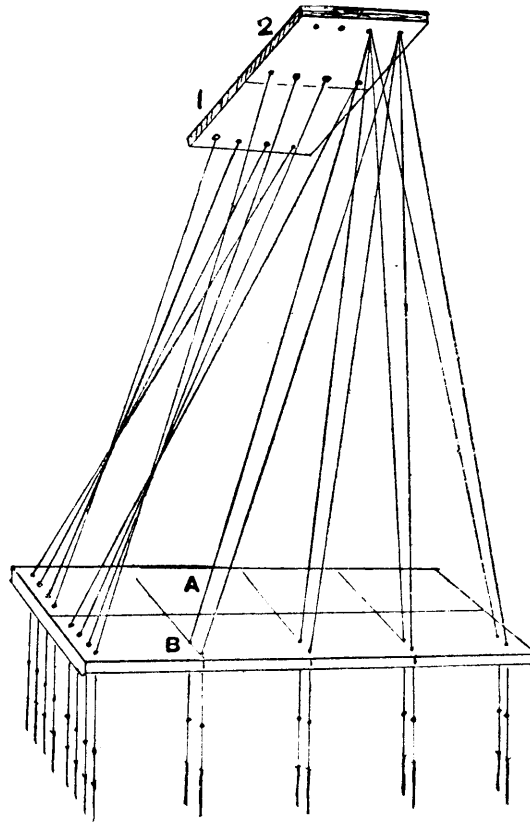

FIG. 156

tion of the work similar to cutting two cards from one line of the design paper would have to be sought for in the mounting in the first place, and in the card-cutting, to suit it.

Suppose the design to be as in Figs. 152 and 155, and to be painted for a 200-jacquard, then to allow for double the quantity of

warp a 400-jacquard would be required, the machinery being increased instead of the number of cards. Now, to mount a loom for this class of work the simplest plan is to divide the machine and cumber board into two divisions, one half being used for one warp, which may be called the face warp, and the other half for the other warp, which we may call the back warp. A mounting of this description is shown in Fig. 156, in which the machine is divided into two portions, 1 and 2, with 200 hooks in each ; the cumber board is also divided into two sections, marked A and B. Here only four rows of needles are given, but any number can be used. The cords from the hooks 1 to 200 are taken through the back cumber board A, and those from the hooks 201 to 400 through the front cumber board B.

When entering the yarn, one thread is taken from the back warp and drawn into the first mail of the back harness, and the next thread is taken from the face warp and drawn through the first mail of the front mounting. Now, in reference to the card-cutting : instead of cutting two cards one the reverse of the other, one half of the card must be cut the reverse of the other half, the card-cutter cutting the coloured squares of the design (200 checks) on the first half of the card, and going back again and cutting the blank squares on the second half of the card ; or, when there is any variation in the twill, the pattern for the face may be painted on 200 checks, and that for the back on 200 checks, and when cut on the card the threads of the warp will be raised in proper order by the mounting.

Fig. 157 shows this principle of mounting with a straight or Norwich tie, for which it is not so suitable as for the London tie (Fig. 156) on account of the crossing over of the harness, though it is not very objectionable if a narrow cumber board be used. Instead of having two separate cumber boards with four or eight rows in each, one broad board with eight or sixteen rows is better for the Norwich tie ; then let the first row of the back harness pass down through the back row of the cumber board, and the first row of the front harness pass through the second row of the cumber board, and so on, the back harness filling the odd rows and the front the even rows ; and when drawing in the yarn, taking an end from the back and face warps alternately and drawing

them regularly over the harness causes them to fall correctly on their respective mountings. Instead of dividing the card in this way and reducing the machine to half its figuring capacity, a double-cylinder machine might be used, the hooks from one set of needles being used for one mounting, and those from the other set of needles for the other

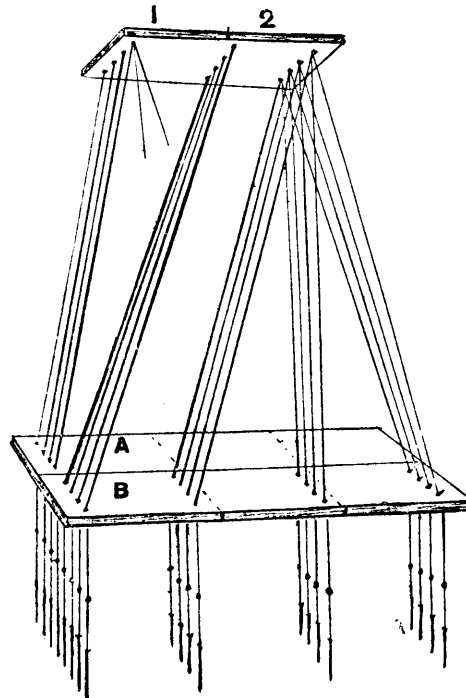

FIG. 157

mounting ; then cutting the face pattern on one set of cards and hanging them on one cylinder, and using a second set of cards containing the back pattern for the other cylinder, should attain the same results, and give double the extent of pattern on the same size of machine, both griffes being raised and sunk together, and both cylinders being also brought in and out together.

A modification of cutting the back and face pattern on its own half of the card is to be found in the double-cloth quilting mounting

common about Paisley. These quilts are generally of a plain texture, and the figuring is formed by passing one cloth up and down through the other. The machine generally used is an improvement on the old French draw loom, and is shown in Fig. 158 as it is made, principally of wood, for hand looms. In this sketch the needles and cords in lieu of hooks are not shown, but one row of them is shown in Fig. 159 with only four hooks to each section instead of eight. H and K are the two lifting levers for raising the griffes or trap-boards A and A' (Fig. 159). Nos. 1, 2, 3, and 4, and 1a, 2a, 3a, and 4a are the cords in lieu of hooks to which the harness is connected. A and A' are two per-

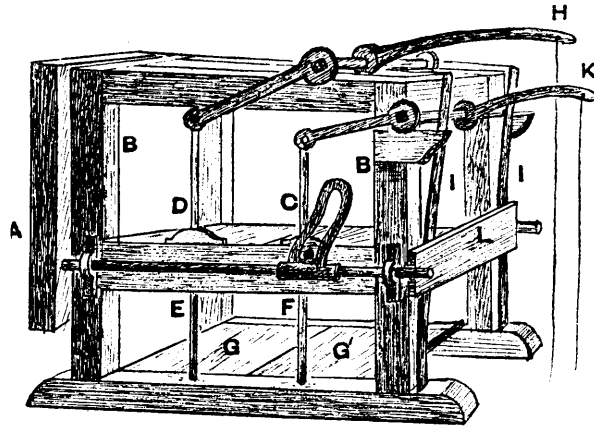

FIG. 158

forated boards with the slotted holes through which the cords pass, turned in the reverse direction in one from what they are in the other. Each needle is connected to two of these cords—one through each hole-board—and the knots on the cords above the holes stand over the slots or saw-cuts of the holes in the board A and over the round or open portion of the holes in the board A', clearly shown at F (Fig. 159), so that if the lever H (Fig. 158) were pressed down and the board A raised without any card acting upon the needles, all the harness tied to this portion of the machine would be lifted, and if the board A' were raised by the lever K, none of the harness tied to this portion of the machine would be lifted. Now, if a blank card were placed on the

cylinder, the reverse of this would be the case, and anything between these two extremes can be got by cutting the cards.

The cylinder is connected with the back griffe only, and remains in for two shots. The griffe A is first raised, and a shot thrown in; it is then lowered, and the griffe A' raised, which presses out the cylinder and changes the card; a second shot is thrown in, and so on. E and F (Fig. 158) are two slide rods or spindles to steady the griffes or trap-boards when rising: G and G' are bottom hole-boards to steady the cords; L is a clap-board for pressing back the needles instead of springs

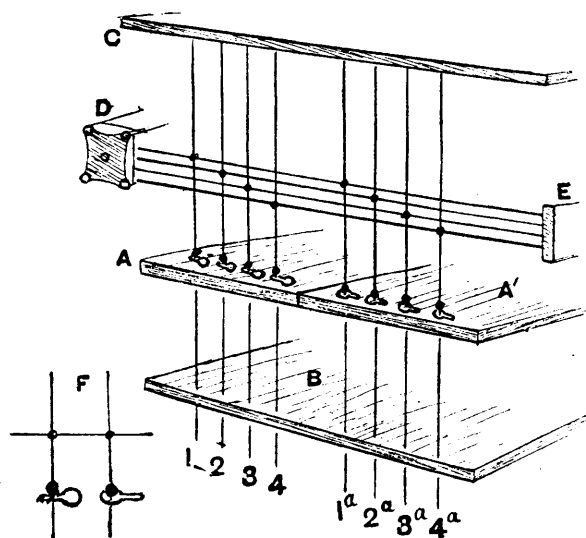

FIG. 159

(it is fastened on springs l , which hold it out a little from the needles, and these springs are fastened from the top by cords to the cylinder frame, which slides out with the cylinder, and draws in the clap-board, pressing forward all the needles). Now to mount this machine for double cloth. Suppose each frame to have 400 cords, and that there are 400 needles, the same as an ordinary 400-machine. Let the texture of the cloth be plain, and to work this 80 needles may be set off, leaving 320 for figuring. These 80 needles will be connected to 80 upright cords in the trap-board A, and the same in A'. The harness for

the face cloth is tied to the remaining 320 cords in the trap-board A, and that for the back cloth to the 320 cords in the trap-board A', and this portion of the harness works the figuring only without the texture. The texture is wrought by the 80 cords in each board connected to the first 80 needles. To each of these upright cords a number of harness twines are tied, one of which is fastened to each twine of the harness from the 320 cords, just above the cumber board; but in doing so the twines from the 80 hooks on the cords in the trap-board A must be connected with the twines of the harness from the trap-board A', and the reverse for the other set. In this way all the back harness could be raised with either griffe, and the same with the front harness. Either griffe could raise one warp with the plain harness, and the other with the figuring harness. When cutting the cards plain texture is cut on each card for the first 80 needles, and the figuring portion without any texture is cut on the remainder of the card. The 80 cords open the texture or plain shed, and the 320 cords keep the two warps in their proper places, raising what should be above the weft, and leaving down what should be below it for each shot according to the pattern. In these mountings the cards hang over the side of the loom.

The same method of working can be applied to a jacquard with upright hooks, by having the heads of the hooks for each machine or set turned in opposite directions, as shown in Fig. 160. One set of hooks stand with their heads over the knives in the usual way, as at A, and the others require to be pushed back by the card to bring them over the knives, as shown at B, so that pushing any needle back pushes the front hook connected with it off the knife and the back one over the knife. The mounting may be made up as before, or a twill or any smaller texture may be used instead of plain; or a different texture may be made on face and back cloths.

This description of cloth is much used for other makes of goods as well as quilts. Kidderminster or Scotch carpets are woven on the same principle, and curtains, cotton vestings, &c., are frequently woven with the same texture. It can always be woven with a full harness mounting by preparing the design to suit it. Fig. 161 is a pattern for

a diagonal figure in plain texture for this class of work. The black squares represent the face warp raised to the face of the cloth, and the shaded squares represent the back warp raised to the face also. The blank squares represent weft on the face of the cloth. This would give

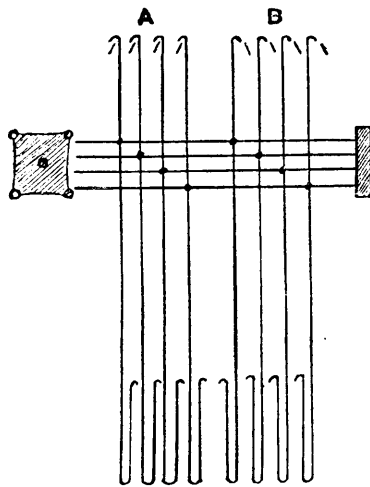

FIG. 160

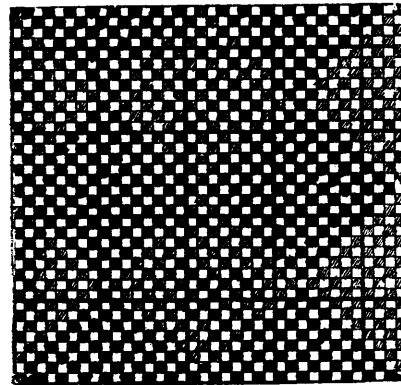

FIG. 161

a magnified view of the face of the cloth if it were woven with a black face warp, a grey back warp, and a white or light-coloured weft. If each warp had a weft of its own colour the effect would be as shown in Fig. 162, which would be the way the pattern would be painted on

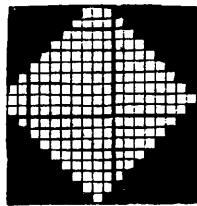

FIG. 162

the design paper if intended for weaving on looms specially mounted, or with special machines as described; but if a full harness is to be used, then the pattern must be spread over the design paper so as to give a line of the paper for each thread of warp and pick of weft. Fig. 163 is the same pattern arranged in this way. The black and grey squares represent the face and back warp raised for the pattern. The crosses show where the back warp is raised for the texture of the back cloth at the back of the face cloth, and the dots represent the face warp raised for the texture where the face cloth

goes behind the back cloth, or where the back cloth comes to the face. Of course, on a cloth of this kind the warps are alike, face and back.

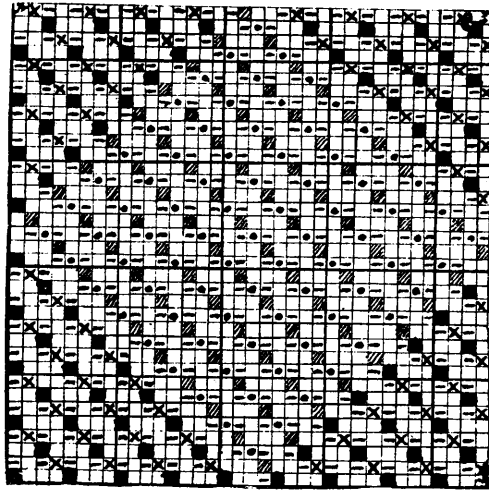

FIG. 163

It will be understood that, when the threads of the back cloth are being raised to form a shed, all the face threads of the corresponding portions must also be raised to clear them out of the way of the shuttle, and the raising marks for these are the short dashes on the painting. Fig. 164 is the same pattern arranged for two threads face to one of back, which admits of a heavy backing with a fine face, and is suitable for quilts, &c. The markings are similar to those in Fig. 163, but the number of threads is not such as to admit of the plain texture repeating on the back cloth. It is therefore broken round the edges of the figure where it would least show.

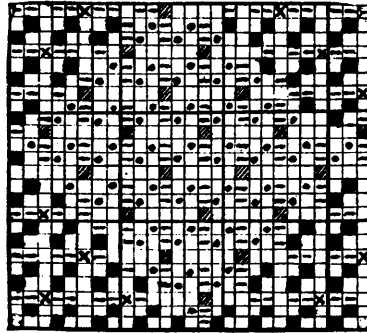

FIG. 164

Instead of having the extra harness for working the plain texture

as explained in connection with the quilt harness, Fig. 159, it might be done with four leaves of long-eyed heddles in front of the harness, or by having shafts through loops in the harness to act as heddles, or by having the cumber board divided into strips for each row of the harness, and knots on the harness twines above them, so that raising any strip will raise a row of the harness, or the machine may act as a twilling machine to work the texture.

A Marseilles quilt is a double cloth with a fine face and a coarse back, both stitched together round the edges of the pattern, and a wadding shot thrown in between them, which causes the pattern to be embossed or to rise up full and rich. The face is usually a plain texture, and the back the same; but the face has double the number of threads in it that the back has, and the yarn for the face is proportionately finer than that for the back. Two picks of fine and two of coarse weft are thrown in alternately—one pick of the fine goes into the face cloth only, and the other, also a face pick, stitches the face to the back. One of the coarse picks is thrown in between the two fabrics, and is called the wadding, and the other pick goes into the back cloth. In these fabrics a very fine effect can be produced by covering the ground with a small bird-eye pattern, stitching the back and front closely together, then having a bold floral pattern for the figuring, which, being only bound round the edges of the pattern and along veins, &c., is comparatively loose and produces a rich embossed effect. These fabrics may be woven with a twilled as well as a plain ground.

Matelasses are a similar description of fabric, but usually more ornamented, the face fabric being any fancy texture. When used for ladies' jackets or mantles they are made of fine worsted or silk for the face, with perhaps a woollen back and a woollen or cotton wadding. The binding of the face and back cloths together takes place round the edges of the figure, and in any other portion, such as veins of leaves, &c., that may be thought desirable. The binding may be effected either by leaving down a portion of the face warp when the back pick is being thrown in, or by raising a portion of the back warp when the face pick is being thrown in, this depending upon the pattern and the counts of yarn used. The finer threads should be used for stitching,

so as not to injure the face by bringing any coarse threads through to it. If the face of the cloth is a warp pattern it will be best to stitch by raising a back thread over a face pick, but if the face is a weft pattern then sinking the face warp for the back picks will probably be more satisfactory. If the cloth is made, as is frequently done, with a mohair or lustre worsted warp face with a cotton weft, and a cotton warp back with a woollen weft, and a woollen wadding, then the binding would be effected by raising some of the back warp thread over the face picks. One pick (woollen) for wadding would be thrown into a shed formed by raising all the face warp; the next pick would be for the back, thrown into a shed formed by raising all the face warp and that portion of the back warp required to form the texture of the back cloth; the third pick would be for the face, thrown into a shed formed by raising the portion of face warp required for the pattern, as well as those ends of the back warp that are to form the stitchings.

Quiltings.—A great variety of the cheaper description of quiltings, toilet covers, &c., consist of a face cloth with an additional thick weft. This thick weft is woven into the ground, which may be a twill, mat, &c., but flushed loosely at the back of the figure, which is a plain texture. Sometimes there is a small quantity of thin warp for binding the thick weft loosely at the back of the figure, making a double cloth in this portion, but all working together for the ground, making it a solid cloth.

Of more recent origin are the satin quilts made by Messrs. Barlow and Jones, of Bolton, and some other firms. They consist of two plain cloths, intimately bound together; one cloth has a fine warp and a very coarse weft, and the other has a fine weft and a coarser warp. When binding, the fine warp is made to catch on the fine weft, and the thick warp and weft cover the bindings. Suppose the fine warp to be white and the thicker warp to be blue, and let the warping be two threads blue and one white. Let the white warp be wefted with a thick twist weft—say four times as thick as the warp—and this coarse weft will form the figure. Let the blue warp be wefted with a blue weft perhaps double the count of its warp, and in binding this weft

catches on the fine white warp. The thick white weft, which is fully double the thickness of the thick warp, effectually covers the tie, and when the yarns are properly proportioned the pattern stands out, producing a clear stamped or embossed effect. These cloths may be made with a twilled ground, and either all white or white and coloured. They are a good firm fabric and wear well, but are liable to have a coarser appearance after being washed. (See also Terry-Pile Quilts.)

Woollens and Worsted.—Weaving woollen and worsted cloths in the jacquard loom is merely an extension of the patterns produced with shaft mountings, or sometimes the same patterns are woven on small jacquards by those who prefer the jacquard to working a larger number of healds when the cloth is not so heavy as to require the latter to be used, healds as a rule making a firmer and heavier cloth than a jacquard will. Light worsted goods for dress fabrics, &c., are figured like damask, or as double weft or double warp-faced cloths, or may be as double cloths.

Curtains and Tapestries.—These, though sometimes of damask, are usually made on some principle of double cloth, as indeed all cloths must be when a rich brilliant effect of colours is required. One of the simplest methods of making these fabrics, and which produces a very good effect, is to employ a fine binding warp of twist cotton and produce the pattern on it with two, three, or more coloured wefts of worsted, mohair, or silk—say a spun silk ground weft and a mohair or fine worsted figure. A small portion of a diamond pattern, greatly reduced for want of space, is given in Fig. 165. It is intended for three colours of weft—one for the ground and two for the figure. The ground weft might be black or gold, and the figure wefts olive green and dull red, or claret, the warp to be black or a deep navy blue.

For this pattern three cards must be cut from each line of the design paper—one for the ground weft and one for each colour of the figure. The design is painted in various colours, which are here represented by different markings on the squares. Let the black squares represent the olive and the dotted squares the red of the figure. The white squares represent the ground weft, and the shaded

squares on it are for binding the face weft down, while the crosses are for binding up the weft at the back. The cutting of the cards is as follows:—For the ground shuttle cut all the shaded, black, and dotted squares—that is, the shaded squares on the ground and all the figure. For the first figure shuttle (olive) cut all the ground except the crosses (that is, the white and shaded squares) and the dotted squares of the figure. For the second figure shuttle (red) cut all the

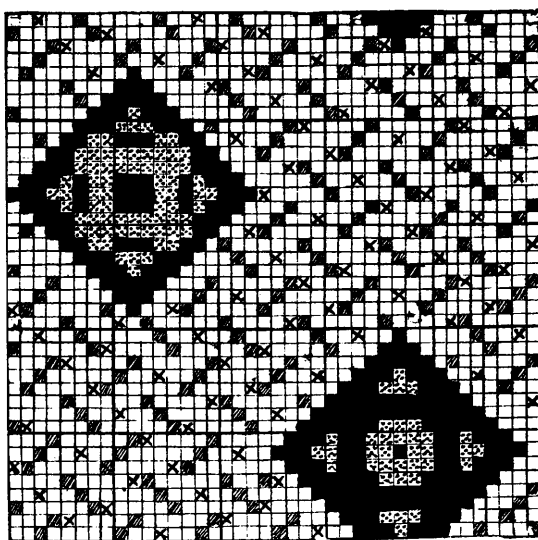

FIG. 165

ground except the crosses, as before, and the black squares of the figure.

In this example the figure is so small as not to require binding dots over it, but for a large figure the ground weft threads would require to be bound up at the back of the figure in the same way that the figure threads are bound up at the back of the ground in the design given. The figure wefts might also require to be bound at both face and back. On the design these binding marks would be dotted over the figure in the same way as they are dotted over the ground on the design given, using any suitable texture that may be desired.

To make the cutting clear, five lines of the pattern (Fig. 165) are put upon design paper in Fig. 165 A, as they would be cut on the cards, beginning with the ground weft, olive and red following, in all making 15 lines or 15 cards. This cutting would make the upper side of the cloth in the loom the right side or face; but it may, in some cases, be desirable to weave the cloth with the face down to avoid heavy lifts in the harness. This pattern would suit for a warp of about 50 threads of warp per inch, and say 60 to 80 shots per inch of each colour.

For the convenience of the designer and card-cutter, a much better plan of working this class of fabric is to have an additional binding warp, which may be in heddles or in a front row of the harness. This warp can work plain twill or satin as required, and, being light and openly set, can bind the back weft up and the face weft down, or the

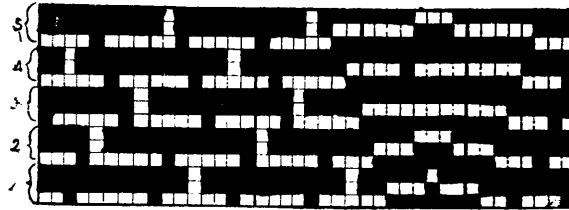

FIG. 165 A

face may be bound by the warp in the harness and the back bound by the binding weft; but in this case there should be a fine thread of weft thrown in every fourth pick, which should pass over the warp in the harness, or a portion of it, and under that in the heddles, so as to bind both warps together. In this case the twilling dots on the design are omitted, which simplifies the cutting and designing of the pattern. If the face is to be twilled with the harness warp, the dots for binding must, of course, be put on the design, or the figure only may be twilled on the design, and let the ground be bound by the binders. Shafts mounted in this way may be wrought from tappets if the loom is mounted with them, or may be wrought by strong hooks at each side of the jacquard and sunk with springs. The principle of working fabrics of this description has been given in detail, as from it many other

varieties can be wrought out, and any number of shuttles used to suit the colours wanted.

Figuring with two warps and one weft is a common method of working, and gives three colours on the face of the cloth. An extra warp of fine yarn may be used for binding the wefts, admitting of the coloured weft being more used for figuring. Extra warps cannot be used to so great an extent as extra wefts, as they crowd up the reed and prevent proper shedding, particularly when soft or hairy yarns are used; but when properly suited to the reed they make a firmer and more regular cloth than a weft cloth, and on account of less picking the weaver gets over the work much faster. Two warps, each having its own weft, are a good method of figuring, but unless for goods with a large number of threads and picks per inch, so that fine yarn can be used, it makes a heavy cloth. Two warps and two wefts, all of different colours, with a fine binding warp in addition, to admit of the colours of the wefts being kept comparatively pure, gives a still richer effect. In this case the binding warp may be of fine black cotton, the two figure warps of thicker cotton, and two threads drawn into each mail; the colours may be, say, dark blue and dark citrine, or clear sage. The wefts are soft wool or worsted, say light gold and deep dull red. In this method of weaving, pure red and pure gold can be got from the wefts, as the black binders show but little. Pure blue and pure citrine can be got in small quantities by floating the warps, and an admixture of the warps and wefts can be got in any place desired.

A very handsome curtain fabric can be made as follows:—There are 120 to 140 threads of warp per inch; every second or every fourth thread of the warp is used for binding the ground, which may be a plain texture or a three-shaft twill. The binders may be an extra warp, wrought with heddles, forming plain all over the cloth, or may be in the harness and be portion of the ordinary warp working plain for the ground, but rising to assist in forming the figure, which may be bound as desired, say 8- or 10-end satin. The warp is of fine silk yarn loosely twisted, and may be one or more ply, of a rich olive-green or deep scarlet colour. There are two wefts, one a rich silk, say a golden colour, of twist yarn; the other is a backing weft of the same colour

as the warp, and of cotton yarn, about the same thickness as the silk weft. There are from 50 to 60 threads of weft per inch of each colour. The gold weft forms the ground of the pattern, and the warp the figure, which is bound with an 8-end satin binding. The cotton weft goes to the back when the silk weft is on the face, forming the ground of the pattern, the warp lying between them; but when the warp is on the face for figuring, the gold weft goes to the back and the cotton weft lies under the warp face, binding it and giving an embossed effect to the figure. The gold weft is bound up by sinking a portion of the warp. The ground may be formed with the warp, and the figure with the weft, if desired, producing a sunk figure on a raised ground; but this is just a reversal of the process, or making the ground in this case as the figure in the previous case. This makes a light, close, and very rich fabric.

Figured Poplins are among the richest description of curtain fabrics; they may be made of all silk, or silk and fine wool, the latter forming the weft. The ground is a clean, sharp cord running across the cloth, and the figure is formed by flushing the warp over the cords, binding it with a long twill or satin binding. The weft may also be used for figuring; but in this case it should be a silk weft put in for the purpose of figuring.

Two portions of patterns of good makes of figured poplins or repps are given in Figs. 166 and 167. Fig. 166 is warped two threads of rich crimson silk and one thread of rich golden yellow silk, 180 threads per inch. The weft is pick-and-pick, 50 picks per inch, one thread a round, firm cord of firmly twisted worsted of the same colour as the warp, and the other yellow silk, the same as the warp. This thread passes over the crimson warp and under the yellow, the crimson cord reversing this, thus producing a very fine yellow line between each pair of cords. The method of forming the figure can easily be seen from the pattern. Instead of a thick cord being put in for the weft to form the rib, several fine shots could be thrown in as one, as in repp figuring, and these threads could be brought out for figuring as well as the warp; but they would in this case require to be of silk, which would make the cloth very expensive.

Fig. 167 makes a very rich and handsome fabric. It is warped all a rich purplish-brown silk, 180 threads per inch. There are four weft picks in the pattern. The first is a clear olive-green silk about double the thickness of the warp silk, the second shot is a round, firmly twisted worsted cord of the same colour as the warp, the third is the same as the first, and the fourth is silk of the same colour as the warp. There are 100 picks per inch, but the two green silks go along with the cord to form the complete cord or ridge. These silk picks can be brought out to the surface for figuring, as shown by the shaded squares in the pattern, which are not cut on the cards. The black squares are

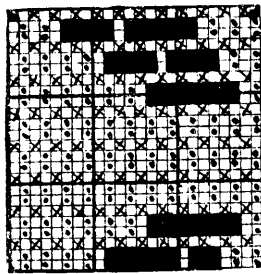

FIG. 166

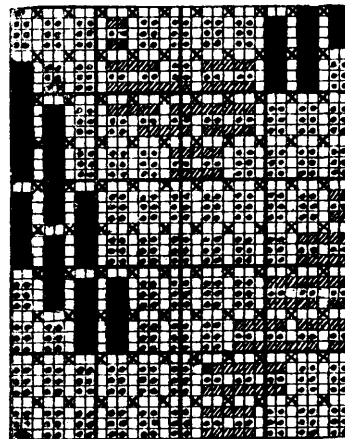

FIG. 167

the warp figuring, the dots the warp raised for the ground, and the crosses the warp of the binding threads raised. These binding threads rise over the brown silk pick, and are similar to the yellow warp in the previous pattern.

For richer fabrics than these we must go to pile work, which is, perhaps, the most exquisite production of the loom. Curtains or hangings can be made extremely rich by figuring a rich corded silk ground with a pile of different lengths and colours. The long pile can be cut to form a plush or velvet pile, and the shorter pile may be left uncut to form a looped or terry pile. By a judicious arrangement of colours and length of pile, fabrics of extreme beauty can be made (see

Pile Work). For curtains of a heavy description chenille is much used, and makes a very rich, warm-looking fabric; but it is too heavy and of too coarse a nature for small rooms unless they are very well lighted. It is very suitable for screens, or curtains dividing two portions of a room (see Chenille).

CHAPTER IX

TAPESTRY AND PILE WORK

Tapestry.—What are generally known in trade as tapestries, are figured fabrics for curtains, hangings, &c., not damask, which is distinct, being woven with only one warp and weft. Real tapestry is a hand-made fabric of very ancient origin, being in use since the days of the ancient Egyptians, who wove or worked it in a manner very similar to that employed at the present time. It does not belong to ‘jacquard weaving,’ but being the first in point of the excellence of its patterns amongst figured fabrics, a short description of it may not be out of place. Henry VIII. tried to establish tapestry weaving in this country, but failed, but James I. had a flourishing factory at Mortlake. Tapestry weaving appears to have been introduced into France about the ninth century. The Flemish were celebrated for it from the twelfth century. Arras work surpassed all the others, and tapestry was commonly known as arras work. The sixteenth century gave a new impulse to the trade in France. Francis I. founded the manufactory of Fontainebleau, and Henry IV. re-established tapestry making in Paris in the years 1595 to 1606. About the year 1666 Louis XIV. bought the Gobelins Works (which take their name from the original owners, a rich family of wool dyers), and established the Royal Gobelins Tapestry Manufactory, which is now one of the sights of Paris.

There were two methods of working tapestries—one known as ‘basse lisse,’ or low warp, the threads of warp being placed in a horizontal position in the loom; the other was called ‘haute lisse,’ or high warp, as the threads of warp were placed in an upright or vertical position. It is the latter method of working that is now adopted.

The loom consists of an upright frame of wood of a size to suit the

cloth to be made. There is a strong roller at the top, which acts as a warp beam, and another at the bottom for the cloth beam. Both these rollers have ratchet wheels on one end, and are held with pawls or catches so as to allow the warp to be wound off and the cloth to be wound up when required, and then hold the stretch of warp steady to be woven. The warp is coarse, but a clean, regular thread of twist, cotton, or linen, about 12 to 18 threads per inch (more or less, as desired,) and of such a thickness that the spaces between the threads are somewhat less than the diameter of the threads. The weft is usually of fine wool but a fairly thick thread, say 4's or 6's worsted. This is generally used alone, of whatever shade of colour is required, and there is no end to the shades used; but in some places, to give brilliancy and richness of effect, silk is used along with the wool, and sometimes tinsel or gold cord. These are put in separate threads along with the woollen or worsted weft. The silk is much finer than the worsted, say about equal to 12's or 16's cotton, and, of course, can be regulated to give the effect required. The gold is sufficient to give sparkle to the portion it is employed in.

After leaving the warp beam the warp is divided by two thick glass lease rods. Then every alternate thread, those to the front of the frame, is drawn through a doup of a half-leaf of heddles which is fixed in a horizontal position above the weaver's head. This enables a plain shed to be formed, as the thick lease rod divides the threads and forms one shed. Then, when the weaver, sitting at the back of the loom, draws back the half-leaf of heddles, all the front threads or any portion of them can be drawn back past the back set, and form a cross shed. As the doups of the heddles are long and strong, the weaver can take any number of them he requires and draw the front warp back; then putting his fingers into the shed thus formed, clear it down to the fell of the cloth and insert his bobbin.

The pattern is painted on design paper, shaded in the way it is to appear on the cloth, and the weaver must have a bobbin of weft to suit each tint or shade of colour on the design. The outline of the pattern is traced on the warp to guide the weaver, and the painted pattern is fastened up either before him or to one side of him, so as to be con-

venient to read the stitches off it. When ready for work he looks at the pattern and finds perhaps 20 stitches of blue; then he selects a bobbin of the correct shade and passes it through the open shed of the warp round 10 threads; then he draws the 10 doups of the heddles that are round the 10 threads intermediate with and in front of these, pulling them back through the others and forming a cross shed. The same bobbin is now passed through this shed, and the weft pressed down with a pin or comb, both of which articles the weaver uses for straightening and beating up the weft. This covers 20 threads of warp with blue weft. The texture of the cloth is plain throughout, the weft being bent round the warp and pressed close together, forming a rib. Now, instead of completing this weft line all along the cloth, as is usual in coloured weaving, the weaver goes on working with the bobbin he has taken up, following the colouring on the pattern, and may change his bobbin when required for a new shade or colour, and go on working this portion for some distance upwards, and then begin an adjoining portion and work it up in the same way. This will come all right when the outlines of the portion he is working run obliquely; but if they should run upright for any distance in the same direction as the warp, it is plain there would be two selvages coming together without any connection between these portions of the cloth, as shown in Fig. 168. When the pattern runs in a diagonal direction, the weft threads passing across from one warp thread to the next one make a sufficient binding or connecting link between the two colours, as may be seen at the upper portion of this figure, which would be

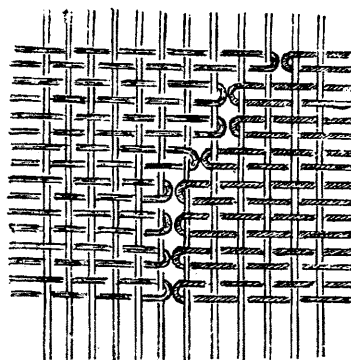

FIG. 168

quite sufficiently connected when it is considered that the weft threads are pressed so closely together as to entirely cover the warp. To remedy the objection of a slit or division between the two portions of

a pattern in the case of a vertical line, it is customary to tack the bobbin of one colour of weft round the first warp thread of the adjoining colour, at intervals of, say $\frac{3}{16}$ in. This produces a toothed appearance, but is not very remarkable. The only other remedy would be to link the two wefts on each other occasionally. In many of the old tapestries it may be seen that this was neglected, even when the distance was as much as 3 in. or 4 in. Sometimes they were stitched afterwards in these places with a needle and thread. When there are many long straight lines running in one direction, as in architectural

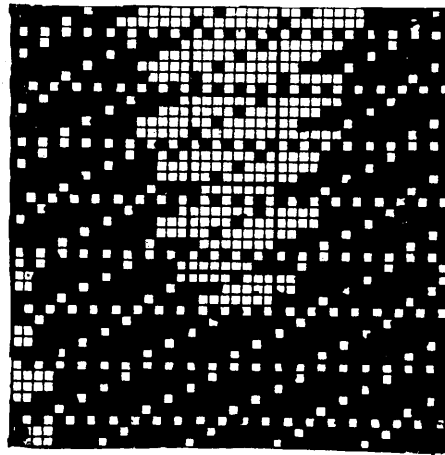

FIG. 169

subjects, it is best to work the pattern so that these will run in the direction of the weft, to avoid any joining being required. Patterns can be wrought sideways or upright on the cloth as desired to suit the size, subject, &c.

As the weaver sits at the back of his frame or loom when working, he has to come round occasionally to examine the face of his work. Sometimes he keeps a looking-glass in front to show him how he is getting on. He has also a rough pattern on the back of the cloth similar to that on the front, as the nature of the weave must give him the same on both sides were it not for the loose ends at each change

of bobbin, which have to be tacked up at the back. Tapestry weaving is a very tedious process of working, but in skilful hands very beautiful, and artistic results can be produced.

Figured Pile Fabrics.—When we come to pile work we have a great scope for the ornamentation of fabrics, but the nature of the work is such that it is only suited to heavy or moderately heavy cloth, and a large number of either threads or picks per inch are required.

Forming stripes of plain or figured pile alternately with twilled or figured stripes can easily be accomplished with either a weft or warp pile, but when we come to figure indiscriminately over the cloth there is more trouble. For a length of time there was a difficulty in cutting weft-pile figured fabrics, as the knife or cutter would not always enter the proper 'race' round the edges of the figure, and the floats were cut irregularly. This has now been overcome by arranging the design to suit. Fig. 169 is a common velveteen designed for a weft pile figure. Only a portion of the pattern is given, but enough to show the method of arranging the design. It will be seen that the figuring is produced by flushing the weft on one side of the cloth, and for the ground it passes to the other side. The edges of the pattern are moved across the design paper in steps of two, and no flush or float is less than over four threads. In addition to this the figure should be turned in the centre on an odd number of ends, which in cutting keeps the race end on the inside of the step into which the knife enters. The knife is run up on all the odd numbers of ends moving across in steps of two, and, leaving no flushes of less than four, gives it a better chance of entering in the proper place along the edges of the pattern.

Fig. 170 is another make of velvet for a heavier fabric, with 60 threads of warp per inch, and from 350 to 400 picks. It makes a good firm cloth, suitable for curtains or furniture coverings. The principle of designing is the same as for Fig. 169. Both these patterns are portions of a diamond figure.

When the figure is produced with a warp pile, it is only necessary to raise the proper warp threads with the jacquard for the insertion

of each wire, but the difficulty to contend with is that there will be an irregular take-up of the warp pile threads, and this can only be remedied by having a number of small warp beams. In some cases a separate spool for each warp thread may be required, which, of course, for a fine velvet means a very intricate arrangement, though it suits very well for pile carpets. Different heights of pile can be formed through a pattern in this way—say, a short pile to be left looped, and a longer pile to be cut, which, in suitable colours of pile and ground, forms a very beautiful though costly fabric.

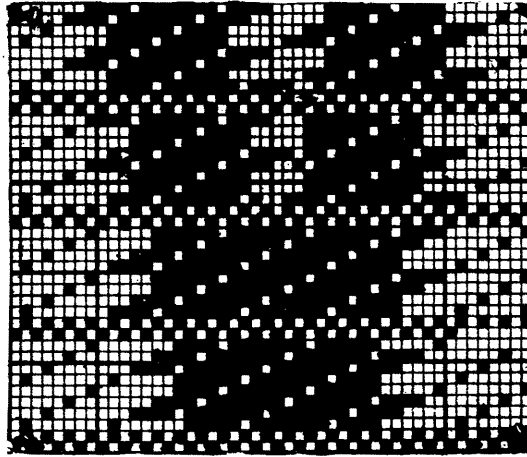

FIG. 170

Another method of warp pile weaving, more easily accomplished, is that known as terry, or Turkish towel weaving. It is largely used for quilts, toilet covers, towels, &c., and any bold figure can be woven on it with almost as much ease as on ordinary damask work.

There are two methods of forming figures on the cloth in this style of weaving, one by having two colours of pile warp and changing them from one side to the other to form the figure or ground—that is, supposing the one pile warp to be red and the other white—pile would be thrown up on both sides of the cloth at the same time; on one side the figure would be formed by the red pile and the ground by the white

pile, and the other side would be the reverse of this. Fig. 171 is a portion of a pattern of this style. The black squares represent, say, the red warp-forming loops on the face of the cloth, and the shaded squares the same for the white warp. The crosses are the ground or binding threads; and the dots represent the pile threads of the colours

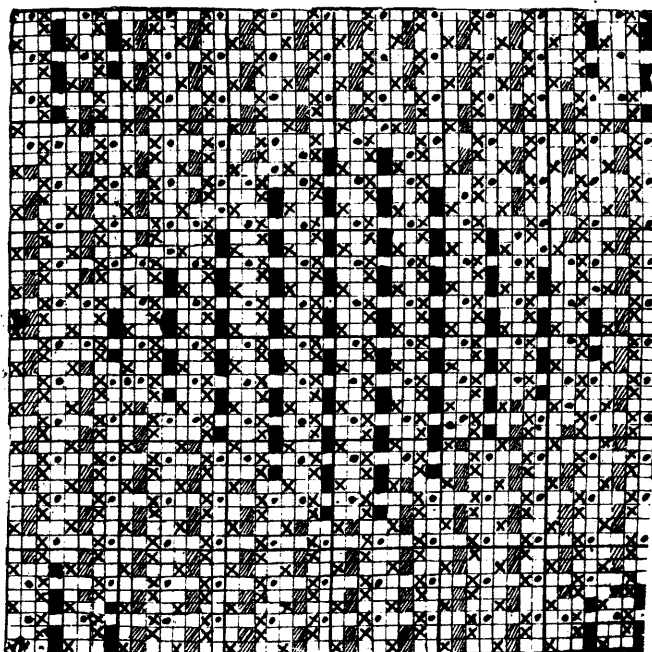

FIG. 171

they are on, raised to bind with the weft, when these threads are forming pile on the underside of the cloth.

The other method is to have only one colour of pile warp—in fact, to have only one pile warp, it might be said, instead of two, as in the previous case. The cloth consists of a pile figure and a plain or solid ground on one side, and the reverse of this on the other side. The pile and ground may be of the same colour, or of different tints if desired—say a rich cream ground and a white pile. This style of

working is very suitable for quiltings, toilet covers, &c. Fig. 172 is a portion of a pattern for weaving in this way. The black squares represent the pile-warp raised to form loops, and the round dots are also pile-warp raised, but only for binding when the loops are being formed at the other side of the cloth. The shaded squares show the ground warp raised to form the body texture. This cloth has about 60 threads of warp per inch, and the same or a little more weft.

Figs. 173 and 174 are two examples of six-shot pile cloth for quilts; it is made with 50 to 60 threads of warp per inch, and double that quantity of weft. The same method of marking the design paper is

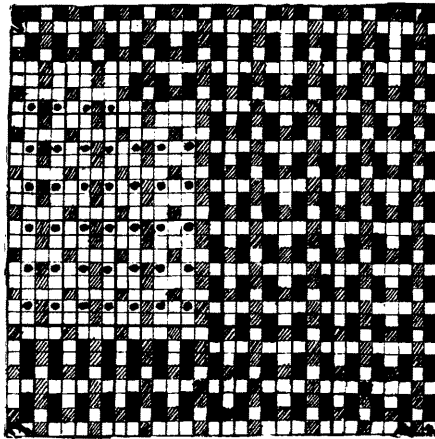

FIG. 172

used as that for 172 pattern. It will be seen that in Fig. 173 the loops or flushes of pile are over five and under one, and in Fig. 174 they are over two, under one, over one, and under one, thus making a fast pile fabric, whereas the floats of five in Fig. 173 would be rather loose unless the cloth is over-wafted. Both these piles may be used in the one cloth, one for the face and the other for the back, as is given in the figures; the light portion of Fig. 173 being of the same texture as the dark portion of Fig. 174. One pattern may be taken as the face of the cloth and the other as the back. Of course they may also be used separately if desired. Any full-harness mounting that will suit

the pattern will answer for these fabrics, the loops being thrown up in the usual way, by leaving a few shots standing out from the fell and then knocking all up, drawing forward the pile warp, which is slackened at this beat, but sliding on the ground warp, which is held firm.

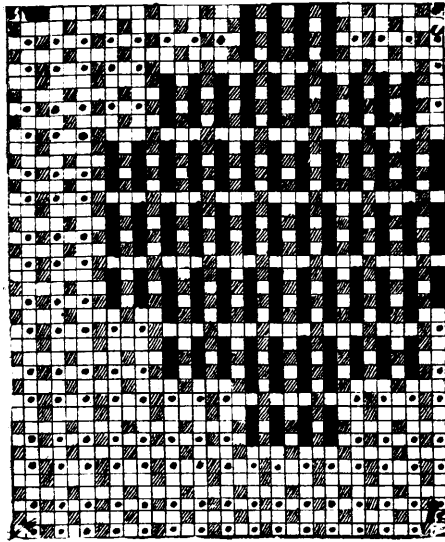

FIG. 173

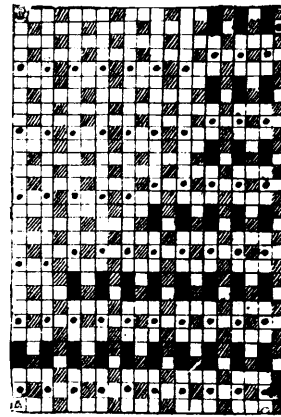

FIG. 174

Another method of forming figure pile is to weave a plain pile, and when cut press or stamp a pattern on it with heated blocks cut to the pattern; the standing pile is then shorn off, and afterwards that which was pressed down is brushed up again, forming a full-pile figure on a shorn-pile ground.

CHAPTER X

CARPETS

THE manufacture of carpets has been in existence since the days of the ancient Egyptians, who made rugs and carpets of various kinds and ornamented them with animals and various devices. The manufacture passed on to the East, and we find India, Turkey and Persia celebrated for the richness of their carpets in early times. The Moors of Spain introduced the Oriental floor coverings into Western Europe, and the Belgians and French took up the manufacture and produced excellent imitations of them. Even in the Middle Ages carpets were only used as a luxury by the rich. Queen Elizabeth had a carpet spread upon rushes, while Queen Mary had rushes only. These rushes were the *Acorus Calamus* (sweet reed of Norfolk), which were the usual floor coverings down to about this time.

Tapestry weaving was started in this country in the beginning of the seventeenth century, but the first we hear of carpet manufacturing in England was at Kidderminster about 1735, the carpets then made being, no doubt, the Kidderminster or Scotch carpet. The making of Brussels carpet was introduced about 1750; they were first made in this country at Wilton, near Salisbury.

The Axminster carpets take their name from being first made in the town of Axminster about 1755. They rivalled the work of the Eastern looms for beauty, durability, and colour; but owing to the cost of their manufacture, and the introduction of the cheaper Brussels and patent tapestry carpets, the demand became very small, and the work was removed to Wilton in 1835. The patent Axminster or chenille carpet was brought out by Messrs. Templeton, of Glasgow, in 1839.

In the early ages carpets or rugs were used for spreading on the floor or grass to lounge upon. It is recorded that in Babylon the guests of despotic sovereigns lounged on rich carpets, and walked over priceless works of textile art; also how figured carpets made of the finest wool were strewed under golden couches, and rugs richly embroidered with figures were spread over daïs, stool, and table.

The Egyptian carpets may have been tapestries and embroidered fabrics. They also had a method of making tufted carpets by drawing a portion of the weft threads out of a piece of coarse linen and sewing tufts of coloured worsted to the warp threads, enough of the weft being left in to bind the warp threads together.

Persian and Indian carpets were made of wool; the latter were occasionally made of silk, and sometimes an inferior description of carpet was made of cotton. These, as well as Turkey carpets, are made on a very simple loom consisting of two posts fitted at a suitable distance apart to form a vertical frame. There is a roller at the top and another at the bottom between which the warp threads are stretched, much in the same manner as in tapestry weaving. The weaver sits in front of the loom with a design before him, and is provided with a quantity of bobbins of the colours required for the pattern; he looks to the design for the colour, and, taking a bobbin of the colour required, forms a loop round two of the warp threads with the weft, cutting it off as shown in Fig. 175. After having completed a row along the cloth forming one weft line of the design, he opens a shed and inserts a ground shot all across the web, each ground shot going into a shed the reverse of the preceding one, forming a plain texture ground with a row of tufts between

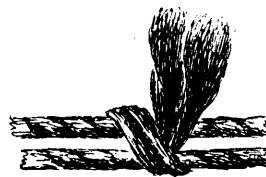

FIG. 175

the ground shots. The ground shots are beaten down with a comb. Instead of going across in even rows of tufts, where there is a patch of colour several rows of tufts may be put in at this place with a ground thread between the rows, leaving the ends of these threads projecting so that they can be carried across when the remaining portions of the rows are completed. The ends of the tufts are cut

off roughly at first, and afterwards shorn level with a pair of shears. Persian carpets are sometimes very costly, a small-sized carpet, when made of fine cashmere wool, costing 500*l.* or 600*l.*

Axminster carpets are made on the same principle, and other art carpets are being made similarly. There are about sixteen or twenty warp threads per inch of strong cotton or linen thread ; the weft is of fine wool, three or four ply being put into each tuft ; the ground weft is soft hemp or flax, eight ply of yarn going to each shot. This makes a full soft cloth. These carpets are about three-quarters of an inch thick, and, like tapestries, there is no end to the variety of pattern or colour that can be introduced.

Kidderminster or Scotch Carpet.—This carpet, also called ingrain carpet, is the oldest machine-made carpet in this country ; it was originally made at Kidderminster, but the chief centre now is Scotland. Originally it was a two-ply cloth, the pattern being formed by passing the two cloths, which were of different colours, through each other. Mr. Morton, of Kilmarnock, improved on this by making it a three-ply cloth, which enabled it to be made a thicker cloth with a richer pattern. It is now made both two- and three-ply, and when made of all-wool is a rich and durable article, taking a position between the jute and felt carpets and the tapestry and Brussels ; it is, however, sometimes made with cotton warps and woollen wefts, and is in this case an inferior article.

Both two- and three-ply carpets may be woven with only one colour of weft, in which case the pattern is formed by the warp threads, which must be much thicker so as to close in over the weft and hide it as much as possible ; on the other hand, there may be two warps and four colours of weft, two of which are the same colours as the warp, and in this case the weft is much thicker than the warp. The best of these carpets are made with as many colours of weft as warp, as, in order to get a pure effect, it is necessary to have wefts traversing warps of their own colour ; but a variety of effects can be produced by using additional colours in both warp and weft.

One advantage in this style of carpet is that it is reversible ; for when one cloth rises to the face the other passes to the back, making

the pattern on both back and face alike, but of different colours. This is the case when the carpet is two-ply cloth woven in the ordinary way, but sometimes the back has to a certain extent to be sacrificed to give more ornamentation to the face, at least in the ordinary method of weaving. Whether woven two- or three-ply, the principle of working is the same. Take a two-ply carpet. The fabric is a double or two-ply plain cloth, figured in the usual way by passing the two cloths through each other, there being no binding between the cloths except what is formed by the one passing through.

The warps are of different colours—as, say, scarlet and black, green and black, &c.—and each warp should have a weft of its own colour if pure effects in the cloth are required. Usually four sets of warp threads are employed instead of two—that is, two colours, end-and-end, for each warp—and each colour of warp has its own colour of weft. Say we take red and black for the face or figuring warp, and white and olive for the back or ground warp. Various effects can be produced from this arrangement—viz. the effect of the figuring cloth, formed by weaving the red and black warps and wefts together, which in plain texture with one weft will produce a rich brown effect; the ground cloth produced by the white and olive warps and the weft will be of a light olive colour; then lined, or what are known as ‘shot-about’ effects can be produced by throwing in a light and a dark shot alternately—as white and black, olive and red—and binding them on the face by warps of the same colour. All the weft on the face of the cloth should be bound by warp of its own colour in order to give pure effects. When a thread of one cloth is raised, the corresponding thread of the other cloth goes to the back (white and red and olive and black correspond in this case), but the red weft will be bound with black warp on the under side of the cloth, and the black weft will be bound with red warp, and the same with the others, as in the system of working the harness with journals to form the texture, all the black warp is controlled by one of the journals and must all rise with it. Therefore when the black shot is being thrown in, the black warp must be raised to make the pattern correct on the face of the cloth, and this will also cause it to be raised for that portion of the cloth that goes to the back, and when the black

is up the red is down ; therefore the black weft must be bound by red warp on the under side of the cloth, and the same with the other colours. It is easy to understand that if an end-and-end warp—black and red—be wrought plain on two shafts or leaves of heddles, and shot pick and pick of the same colours, when the black weft is bound with the black warp on one side it must be bound with red (which is the other half of the warp) on the other side, and if the red is bound with red on one side it must also be bound with black on the reverse side. To apply this to the double cloth or carpet weave it is only necessary to consider this piece of cloth as passing up and down through another one of a different colour. Had we the power of raising any portion of the black or red warps required, we could bind a portion of the black weft with black on one side, and any other portion of it with black on the other side ; to do this we require a full or thread harness.

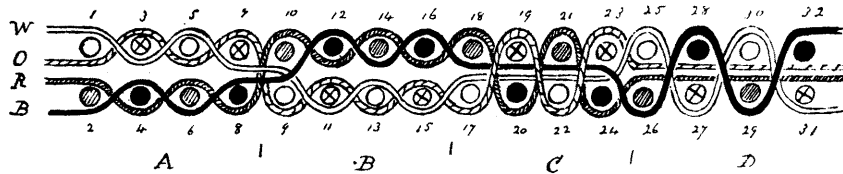

FIG. 176

A section through the weft of a piece of two-ply carpeting is given in Fig. 176, showing the position of the threads when arranged to give the different effects of face cloth up as at A, back cloth up as at B, shot-about effect of red and olive on the face as at C, and shot-about effect of white and black on face as at D. The warp threads are marked W, O, R, B, the initial letters of the colours ; and the numbers 1 to 32 give the order of picking. The shot-about effect is here produced with the opposite threads—that is, the first thread of one warp and the second thread of the other warp—as white and black ; but it might be preferred to produce the effect the corresponding or mate threads (white and red, or olive and black) would give. In working with journals, two picks face and two picks back would be required to obtain this, and the needles of the jacquards would require to be acted upon by the cards for each shot, thus requiring double the number of cards. With a full

harness any effect desired can be produced. Extra colours of weft may also be used (as drab) in addition to the white and olive—to work, say, white, olive, drab, olive, &c.; and dark green or blue in addition to the red and black, which would come in as red, green, black, green, &c., a shot of the light and one of the dark colours following each other in succession. Stripes of a bright colour may be introduced into the warp or weft and kept in the back cloth, only being brought to the face in small portions, at intervals, to sparkle up the centres of flowers, &c.

Ingrain carpets are made 36 in. wide, and with, say, 832 or 1088 threads of warp, according to quality. The former can be woven on a 200 jacquard (say $208=416$), as the machine is double; and as there are two repeats of the pattern in the width of the cloth, $416 \times 2=832$ threads of warp. For the latter 272 needles are required = $544 \times 2=1088$ hooks.

When woven with journals, the jacquards used for figuring these carpets are similar to those explained under 'Quilt Weaving'—that is, double machines with trapboards and knot cords; and when the card is pressed against the needles it is held in for two shots, one trapboard raising the harness for the first shot, and the other reversing the shed for the second shot. The journals are four sections of the cumber board, as shown in Fig. 177; each section contains two rows of the harness and one colour of warp. No. 1 journal controls the white warp, No. 2 the olive, No. 3 the red, and No. 4 the black; the draft is shown by the numbers 1 to 8 alongside the harness cords. These eight cords only represent half a row from each machine, as there are eight rows of hooks to the machine. One row of the two machines fills two rows across the journals, or 16 holes. A represents the trapboard of the machine for the ground or dark warp, and B that of the machine for the figuring or light warp.

The harness twines are furnished with large knots above the cumber board or journals, so that when one of the journals is raised the harness will be lifted with it. The journals may be raised by strong cords or wires from the machine, or by a tappet or shedding motion working either above or below them. If the machine is divided into two parts, four hooks in succession going to each colour of warp

for each cloth, the cords from these four hooks making two rows of the journal, there will be no crossing of the harness in a straight or Norwich tie.

The order of working for the section Fig. 176 would be as follows:— For the first pick, which is white, raise the trapboard B and the first journal; for the second pick, which is red, raise the trapboard A and the third journal; for the third pick, raise the trapboard B and the second journal; for the fourth pick, raise the trapboard A and the fourth journal. This is the general order of lifting for a pattern; but

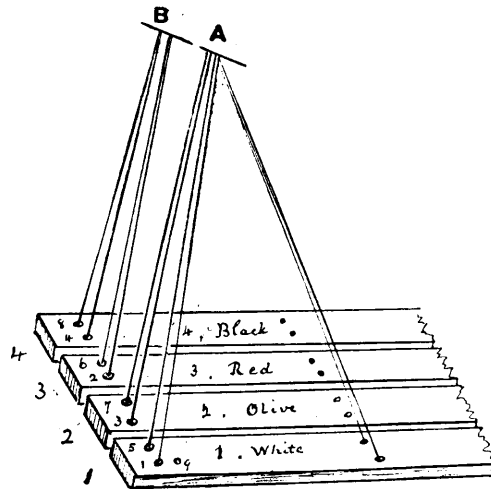

FIG. 177

a simple lined effect across the cloth as the section could be wrought with the journals without the machine, using them as heddle shafts. It could also be wrought by the machine without the journals. The use of the journals in conjunction with the machine is to pass the cloths through each other and make a pattern. For figure work, when a card is pressed in against the needles, all the warp for the figure on the design paper is raised by the trapboard B, which clears this portion of the red and black warps out of the way of the ground shed; and as the first pick of the ground is white, the white journal is raised to bind the white pick, leaving the olive warp down to bind it at the back. For

the next shot the same card acts, and the trapboard A is raised, which lifts all the white and olive warp corresponding with the portion of the red and black that was left down at the last shot, so as to clear this portion out of the way of the face shed. As a red pick follows white, the red journal (No. 3) is raised to bind the red on the face, leaving the black warp down to bind it on the back. The other picks follow similarly. This shows the defective binding common to journal weaving, the white being bound with olive and the red with black at the under side of the cloth. To have pure binding, instead of all the white or red being raised by a journal as above, only as much of either should be raised as is required to bind its own colour of weft on the face of the cloth. The olive or black in respective cases should be raised for the remainder of the shed, leaving the white and red down to bind their own wefts where these colours come out on the back or under side of the cloth, thus giving pure colours on both sides of the cloth, and letting the mixed or impure binding be in the centre between the two cloths. This, however, is beyond the range of journals, and requires a harness.

Fig. 178 gives a neat pattern on a small scale for a two-ply cloth with, say, a red and a pale olive warp for ground and figure cloths respectively, the shaded squares being red and the ground or white squares olive; the weft for each cloth to be the same colour as the warp, or sometimes a tint one or two shades lighter and brighter, or deeper and duller, according to the colours or shades of colours used, gives a good effect. A further effect in this can be produced by having the 6th to 10th and 18th to 22nd threads black, brown,

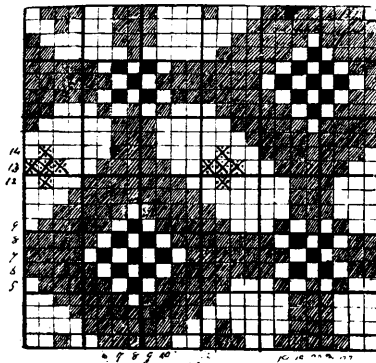

FIG. 178

or dark green, end-and-end with pale olive, for the back warp, and picking similarly on the 5th to the 9th picks for the ground cloth. This would, of course, make a striped effect on the under side

of the cloth, as where the additional colours do not show above they must appear below. A still better effect can be produced by having an additional weft lying between the two cloths which can be flushed on the face in spots as at picks 12, 13, and 14, and of course a three-ply cloth will be a step farther in advance; lined effects can then be produced anywhere desirable, in portions to suit the nature of the design, to vary and enrich it, at the same time the breadth of effect is maintained by working the greater portion of the pattern in masses of pure colour, whether they be large or small. For full-harness work the harness is divided into two sections, four rows for the back cloth and four rows for the face cloth, on an 8-row machine; no journals are used, the machine doing all the work. The harness is tied up in the usual way, the cord from the first hook passing through the first hole of the cumber board, and the cord from the second hook passing through the second hole, and so on.

The harness is nominally divided into two sections, the front four rows being for the face cloth and the back four for the back cloth; when drawing the warp into the harness the mails are taken in the following order: 1, 5, 2, 6, 3, 7, 4, 8, the back or ground warp coming on 1, 2, 3, 4 mails, and the face or figure warp on 5, 6, 7, 8.

Suppose the pattern to be a dice, as Fig. 179, the warps to be white and olive, and red and black, with the same colours of weft. Each upright line of the design represents two threads of warp, one of which will be drawn on the front half of the harness and the other on the back half; and each horizontal line of the design represents two weft shots, for which there must be two cards cut. Let the order of drawing the warp into the harness be as Fig. 180. The white is on the odd and the olive on the even numbers of the four back rows of the harness, and the red is on the odd and the black on the even numbers of the four front rows.

Now to cut the cards:—Take the first line of the design Fig. 179, cut the odd numbers of holes (that is, the first and third) on the first half, or first four holes, of the card, and cut the white and olive on the second half of the card. For the second card, from the same line of the design cut red and black on the first half of the card, and the

odd numbers of holes on the second half of the card. For the third card, take the second line of the design and cut even numbers of holes on the first half of the card, and white and olive on the second half of the card. For the fourth card, from the second line of the design cut red and black on the first half of the card, and the even numbers

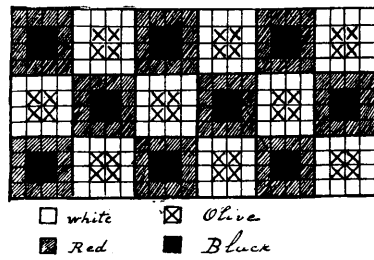

FIG. 179

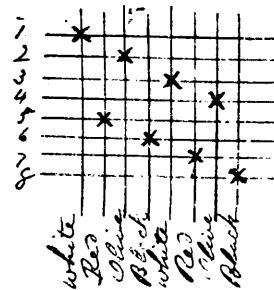

FIG. 180

of holes on the second half of the card. Of course when there is none of a colour raised, as in the first line there is no black, no notice is taken of it. For the pattern in Fig. 178 the cutting would be the same, except that there are only two colours of warp to be dealt with instead of four. No. 1 card: cut odd numbers of holes on the first

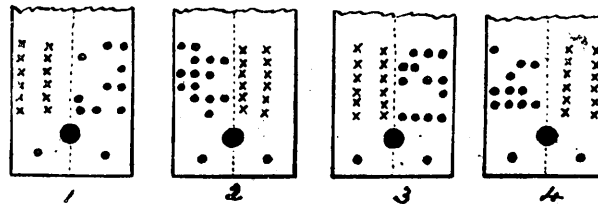

FIG. 181

half of the card, and olive on the second half of the card. No. 2: cut red on the first half of the card, and odd numbers of holes on the second half of the card, &c.

The cutting of four cards is given in Fig. 181. The crosses indicate the cutting of the odd and even holes in the cards, and the dots are the figure. It will be seen that the crosses in No. 2 card would reverse

the shed formed by those in No. 1 card, thus working plain texture on the back cloth, and the same would take place with Nos. 2 and 4 cards for the face cloth. This is simply the action of the journals included in the harness, which it will be seen requires double the number of needles in the machine, and double the quantity of cards; but an ordinary machine and mounting will answer, instead of having to get a double machine and journals.

The above cutting acts the same as journals, and is all right in both cases when one warp with its own weft is used for each cloth; but it has been pointed out that when each warp is end-and-end of different colours with wefts to match, the under side of the cloth is defective when wrought with journals, and so it would be with the full harness if the cards were cut as above. To get each colour of weft bound with its own colour of warp on both sides of the cloth, the following change must be made:—Take the small piece of pattern given in Fig. 182, and let the warps be as before—white and olive,

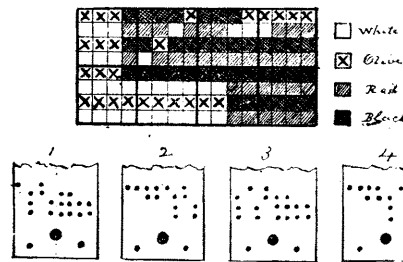

FIG. 182

red and black. The card cutting for this pattern will be as follows, the warp being drawn through the harness as before:

For the first card, cut odd numbers of red and even numbers of white on the first half, or first four holes, of the card, and white solid

on the second half. This will form a shed for the red shot.

Second card: Cut from same line of the design red solid on the first half of the card, and even numbers of white and odd numbers of red on the second half of the card. This is for the white shot.

Third card, for black shot: Cut from the second line of the design even numbers of black and odd numbers of olive on the first half of the card, and olive solid on the second half of the card.

Fourth card, for olive shot: From the same line cut black solid on

the first half, and odd numbers of olive and even numbers of black on the second half of the card.

These four cards are shown in Fig. 182, from which the cutting may be traced. It must not be supposed, however, that cutting odd numbers of red and even numbers of white as on the first card, means that these colours of threads are to be raised; the colour has no reference to the threads—only to the coloured checks on the design paper.

For the first card the white checks on the design paper are cut solid on the second half of the card; this raises the white and olive warp corresponding to the white portion of the design. Then, to form the plain shed in the other warp, the even numbers of the white checks and the odd numbers of the red checks are cut on the first half of the card, which acts on the other warp. As the black warp is drawn on the even numbers of harness twines it will be raised for that portion of the design that is white, and the red will remain down to bind the red weft; but passing along the design till the red weft is above, it will be seen that the red warp should here be up to bind it, and the black should therefore be down, so, as the red warp is on the odd numbers of the harness and on the second half of the card, the odd numbers must be cut on the card for the red portion of the design. This gives a pure binding on both sides: and the same applies to the other colours. It will be seen that the first halves of the 1st and 3rd cards together work a broken plain texture, and the second halves of the 2nd and 4th cards do the same.

In case the card-cutter cannot follow this method of cutting, and if the design is so varied in order of weaving that a gamut or index for cutting cannot be arranged, then it will be necessary to paint the full texture of the pattern on the design paper in the same manner as is done for double cloth. The first row of designs of the pattern given in Fig. 178 is painted out in full in Fig. 183. The shaded lines underneath represent the back warp, and the white lines the face warp. The black squares are the figure, and the large crosses the ground, or the white squares in Fig. 178. The dots are the rising marks for the texture of the back cloth, as would be formed by the back warp journals, and the small crosses are the same for the face warp.

This method of weaving is not confined to carpets, but is equally applicable to quilts, curtains, &c., and a plain texture need not be adhered to; a twill or any simple fancy texture may be used. With 80 to a 100 threads per inch, one warp peacock green in satin texture for the figure, and the other warp gold for the ground in a crêpe or mottled texture, all shot peacock, a handsome curtain can be made.

Brussels Carpets.—Brussels carpets, with their less expensive allies, the tapestries, are the commonest of the better class of carpets. They are a loop-pile fabric, the pile being formed by the figuring warp, which is wool, the ground warp and weft being hemp or flax. As the pattern is formed by raising the figuring warp threads of the required colours, and as any thread of any colour may require to be raised, it follows that all the threads must be on separate spools or small warp rolls, so that any one thread can be drawn forward without slackening

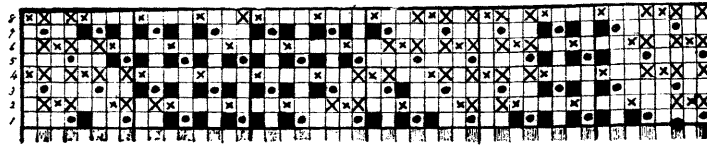

FIG. 183

any of the others. Large frames are therefore made to hold the number of spools of each colour, and these are placed one above the other in a slanting position, at the back of the loom, and when filled with spools the whole set of threads are brought forward to the harness as if from a warping creel or bank. According to the number of these frames used the carpet is styled a 3, 4, or 5-frame carpet, the greater the number of frames the richer the carpet both in colour (generally speaking) and in body of warp. Sometimes 6 frames are used; but 4 or 5 are more frequent, 3 and 4 frame being the lower qualities.

The texture of a Brussels carpet is shown in Fig. 184, which is a section through the weft. A and B are two of the ground warp threads, a pair of these coming between the rows of pile loops, a portion of one row being shown in the section. The weft threads are

shown in section coming under the loops of the ground warp at the top, and above them below. Both this warp and weft are of coarse hemp, about 3's: the weft is steeped in glue size before being thrown into the cloth, which makes it stiff and firm when dry. The pile warp threads are numbered, 1, 2, 3, 4, and 5; they are of soft-spun worsted, about 2/24's, 2 and sometimes 3 threads being drawn in together as one through the mails and reed. These five warp

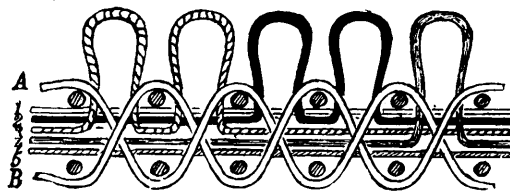

FIG. 184

threads go to form one line of loops, being raised over the wires as is required for the pattern, and lying straight between the weft threads when not raised. By considering this it will easily be understood that each thread must be on a separate bobbin so as to admit of being drawn forward independently of any of the others. In low qualities of these carpets one or two threads of hemp warp are used to each splitful or row of pile threads; the hemp thread lies in a straight line below the

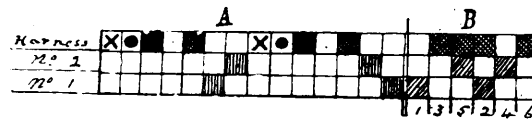

FIG. 185

worsted threads in the same way that No. 5 thread is shown in the section. These stuffing threads add to the weight and thickness when the worsted is reduced in quantity, but make a harsher and stiffer carpet. This warp, when used, is put on a beam or warp roll, as is also the ground warp of the carpet.

Fig. 185 is the plan of drawing-in and weaving a carpet similar to that shown in section in Fig. 184. The draft is given at A, and the

treading and cording for a hand loom at B. A 10-row jacquard should be used for a 5-frame carpet, as twice over the 5 threads makes one row of the cumber board. Five threads are drawn into the harness, one from each frame, then two ground warp threads are brought through and drawn on two leaves of heddles. In weaving, one ground thread is raised and a shot thrown in; then all the pile warp and the same ground thread are raised for the next shot; the third tread raises the harness and a wire is inserted to draw up the pile; the fourth tread crosses the ground warp threads; the fifth tread raises this thread again, as well as all the pile warp, and the sixth tread raises the harness for the insertion of the second wire; this completes the order of treading. For the second and fifth treads it will be observed that all the warp in the harness must be raised; this was usually done by having shafts through the harness or by raising the cumber board to act as a journal in the manner explained for Scotch carpet weaving; but now jacquards are made with bottom boards or gratings that can be raised or lowered to form these sheds.

The pile wires are now commonly inserted at the time the adjoining pick is being thrown in, a double shed being formed, and both the wire and shuttle passed across at the same time, the former being uppermost; in power looms the wires are both inserted and withdrawn by machinery; about twenty-five are inserted before any are drawn out, to prevent the loops from slipping. Jacquard machines are made specially for the purpose of forming this double shed, the grating raising the hooks from the bottom to the centre position, thus raising the worsted or figuring warp above the shuttle, while the griffe carries the figuring hooks on to the top, making a second or upper shed for the wire. The old method was to form the lower shed by raising the cumber board, and the upper one by the griffe. Jacquards with cords instead of hooks are frequently used.

Brussels carpets are made 27 in. wide, with nominally 260 loops or rows of pile in the width; but 256 rows are commonly used instead of 260 for the better classes of goods, and a further reduction of 30 or 40 loops is made for lower classes, the reduction going to cheapen the goods or to the credit of the manufacturer. Although only 256 loops

are on the surface of the cloth, it must be remembered that for a 5-frame carpet there are 5 times this number of threads, and that 1,280 cords will be required for the harness, and an equal number of needles in the jacquard when the pattern is single, or not repeated on the cloth; but the design only covers 256 spaces on the point paper, each space or check across it representing 5 threads. In Scotland a reed with 350 splits on 37 in. is used, one row of pile warp with its ground warp going into each split. A carpet known as Axminster Brussels is made in Scotland. It is similar in structure to the common Brussels, but has in addition a woollen weft, which is thrown in pick-and-pick with the usual hemp weft. The addition of the wool weft adds to the softness and thickness of the carpet, giving more elasticity or spring to it, and making it wear better.

Designs for Brussels carpets are sketched out and coloured in the usual way; the method of repeating the patterns is much the same as is adopted for wall papers. Usually there is one repeat in the width of the cloth (27 in.), and the length of the repeat may be shorter or longer to suit the pattern, expense, &c.; 256 checks, = $\frac{3}{4}$ ths of a yard, is a common length, and $1\frac{1}{2}$ yard for bolder effects. The number of colours must be regulated to suit the frames to be employed in the weaving, unless the frames can be made to suit the pattern. Say five frames are to be used, this would suggest five colours; but it does not follow that only five colours can be used. A clever designer may work out most patterns so that six or more colours may be used on five frames, by arranging the design so that two colours may be put to one or more of the frames, which process is called 'planting.' But it may be that an extra number of colours will not improve the design, in which case they should not be used. The process of 'planting' or striping the warp—which is on the same principle as 'chintzing' by striping the weft in other makes of goods—will be best understood by referring to Fig. 186, which is a Brussels carpet pattern on a small scale for working with five frames. The colours are indicated by different markings on the squares of the design-paper, as shown by the index or gamut below the design. On the first line of the gamut there are two varieties of markings, and as this line indicates reds, there are

two colours of red used on this frame. Following up the design above these markings, it will be seen that one colour of red is used in one of the sets or rows of octagonal figures, and the other colour on the intermediate rows, and that the two colours of red are not required in the same portions of the design, the gamut showing where each is required.

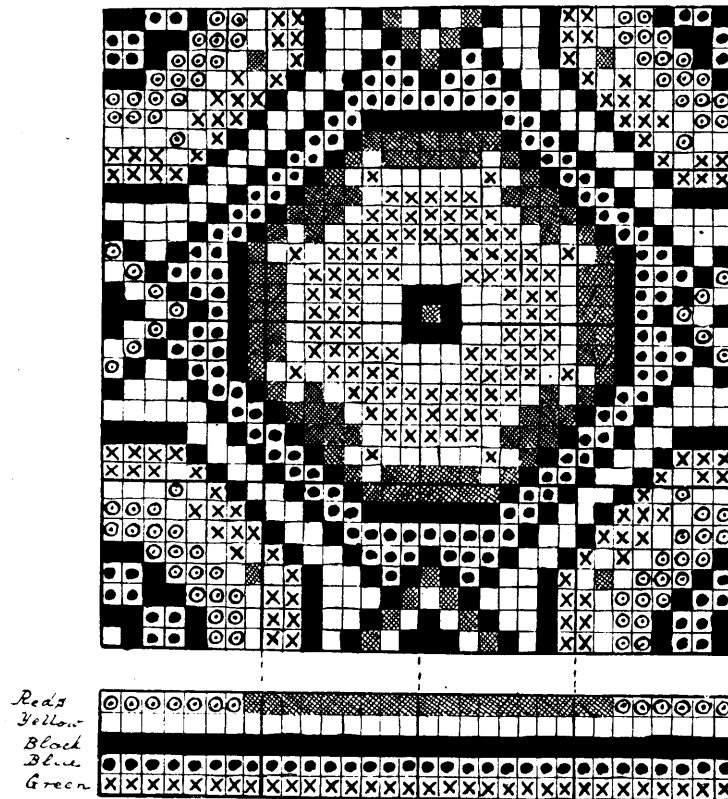

FIG. 186

It is only necessary to arrange the spools on the frame in the loom and draw the threads through the harness, as shown by the gamut, to make this fall in correctly.

What the designer must guard against is giving the pattern a striped appearance, which would be the case if the planted colours

were brought to the surface too frequently ; but if they are judiciously brought up at intervals, the effect of a 5-frame can be made almost as good as that of a 6-frame pattern, and this can be carried still further if desired ; every frame may contain two colours, or one frame may contain several colours.

Carpet patterns are sometimes painted on small-sized design paper — that is, the ordinary paper with, say, two designs per inch ; but before working it is more satisfactory to have them put on large-sized paper, so as to show the exact effect they will have on the cloth, the design-paper giving the pattern full-cloth size.

When painting patterns that are as large or larger on the cloth than they are on the design-paper, much more care and skill are necessary than when the pattern is one that is much larger on the design-paper than it will be on the cloth, as is usually the case ; and in consequence of the large size of the checks required for carpet design-paper, it is evident that representations of any small objects—unless those of a very simple nature—cannot be put on it without being greatly enlarged. After the sketch is made the forms should be carefully adapted to suit the paper, so as to give a satisfactory effect on it, rather than be a rigid adherence to the sketch. Natural floral forms should not be attempted unless to satisfy the demands of trade, and when they must be used they should be made on so large a scale as to be fairly represented in a semi-conventional manner. Large wild-floral patterns are frequently to be seen on carpets, but they are rarely, if ever, satisfactory. Persian, Indian, and other geometric or conventional forms that lend themselves readily to a harmonious admixture of colours so that the carpet will, when on the floor, present a rich glow of colour instead of obtrusive masses of floral misrepresentations, are much to be preferred. Dull colouring is not essential to good taste—rather the reverse ; but it is less obtrusive and more easily managed, particularly in the hands of an inferior artist. No matter how brilliant the colours are, if properly blended and broken up into masses in proportion to their intensities in the spectrum scale they need not be in the least offensive ; but it requires skilful hands to do this.

The pattern given in our last figure (186) is a simple repeating pattern,

so that two pieces of the carpet laid side by side will join correctly together. Another method of arranging patterns so that they will repeat is shown in Fig. 187. In this figure it will be seen that the two sides will not join as an ordinary repeat, but if two pieces are

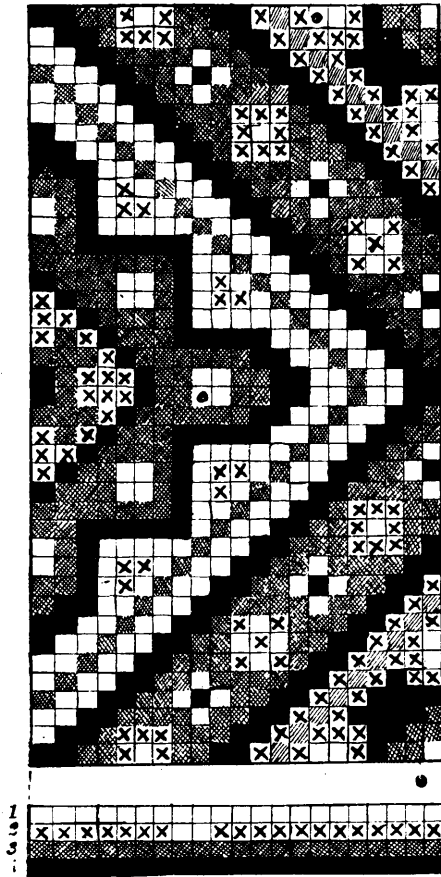

FIG. 187

taken the right-hand side of one will, if turned round, join against the left-hand side of the other, and two pieces thus joined will form a repeat.

This is objectionable in the case of cut pile, which usually has a slope in one direction; and when two pieces are joined, one running one way and the other the reverse, the effect will be that of shaded stripes, somewhat similar to that of a grass field when rolled. Another method of forming repeating patterns is by making what is known as a 'drop repeat,' which is shown in Fig. 188; though the two sides will not join in against each other, as in an ordinary repeat, if two pieces of the carpet be laid side by side, and one of them drawn a little down, the point A in the figure of one piece will

fall in against B and B' of the other piece, and repeat. These show the usual principles on which repeats are based, and of course it is for the ingenuity of the designer to form the best arrangements of pattern he can to suit them, or any other method he may think of.

When cutting cards for carpet patterns the usual method of picking out the various colours for each cutting must be adopted by the card-cutter. Refer to Fig. 186 for the pattern, and to Fig. 185 for the draft. The order of drawing is green, blue, black, yellow, reds, which gives five rows of holes on the card, and this twice over makes the ten rows; therefore, green would be cut on the first and sixth rows; blue on the second and seventh; black on the third and eighth; yellow on the fourth and ninth; and reds on the fifth and tenth rows. These may be all cut when passing the card once along the cutting machine, giving more than one tramp, if necessary, to each shift of the card index; or the cutter, if not accustomed to this, may pass the card along once for each colour, working two of the punches at each passage of the card, and of course remembering to select the punches which correspond to the colour being read.

It must be remembered that two checks on the design-paper correspond with a row of ten holes on the cards, as each check may have any of five colours on it in the case of a 5-frame carpet pattern, and there must be a space

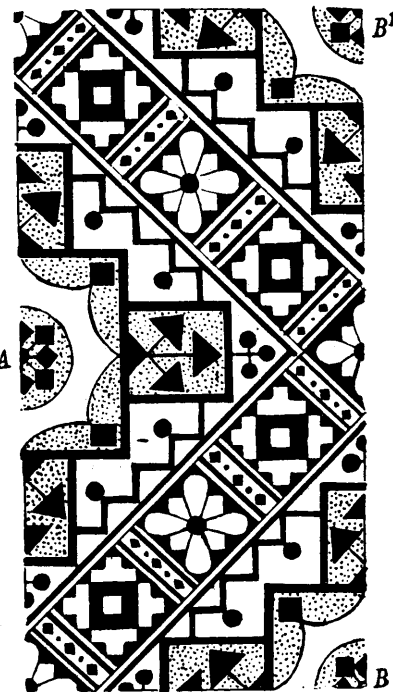

FIG. 188

for a hole in the card for any of these colours; therefore the designs or large squares on the design-paper would consist of two checks each. Suppose one of these checks—the first one—to be green, the first hole in the card would be cut for it; if the second check is also green, the sixth hole on the card would be cut; but if it is black, the eighth hole in the card would be cut, not the third hole, as it, being the second check, comes on the second half of the card. The first check stands

against the first five rows of holes in the card, and the second check against the second five rows, each check on the design-paper representing five threads, five mails and five needles, or five spaces on the card ; but only one hole is cut on the card for it, and that must suit the colour the check is painted.

Wilton Carpets.—These carpets are made much in the same manner as Brussels, but the pile is cut, and they are of a better quality of

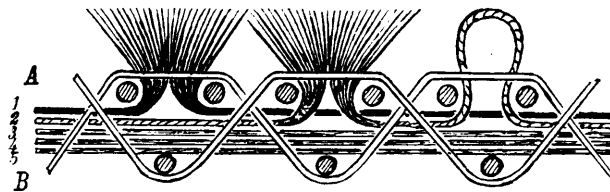

FIG. 189

wool with a longer pile, and altogether a superior article. As the pile is cut, the method of binding it into the ground is somewhat different from that adopted for Brussels, in order to secure a firmer binding. A section of the cloth through the weft is given in Fig. 189, showing two pile loops cut and one uncut, and also the method of binding the pile warp threads Nos. 1, 2, 3, 4, and 5, with the ground warp A and B, and the weft is shown in section, or end view.

The warp or pile threads are cut similarly to velvet by drawing the

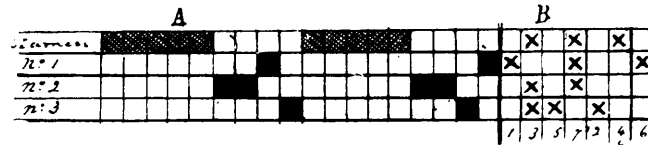

FIG. 190

wires out of the loops and having each wire furnished at its end with a cutting edge. Fig. 190 shows the draft and treading of a Wilton carpet arranged for a hand loom. The back is the harness, and Nos. 1, 2, and 3 the shafts. No 2 shaft is only required when an extra or silent warp is used for the purpose of giving weight and thickening the fabric. This warp, if used, lies straight between the weft, and must be on a separate beam from the ground warp.

Tapestry Carpets.—These carpets, though they do not require a jacquard to weave them, are so closely allied to Brussels, and patterns so similar can be produced on them, that it is thought desirable to give a short description of them. Though figured weaving, they are not so in the strict sense of the term, as the pattern is printed on the warp instead of being formed by various coloured warps; they are simply an imitation of figured weaving in colours. Any pattern that can be put on a Brussels carpet can also be put on a tapestry, and with further variation if desired. The effect is not so sharp and rich on the tapestry, as the colours, being printed on the warp, run into each other more or less, and produce a slight blurring round the edges of the pattern; whereas the pattern on the Brussels is so sharp and clear round the edges as to make it harsh if two very contrasting colours come together,

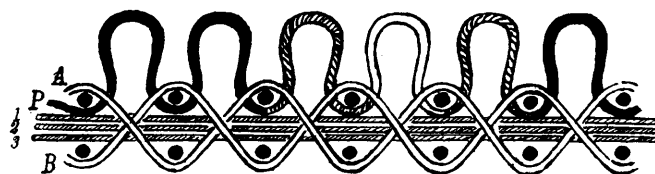

FIG. 191

so that in some cases the tapestry patterns are softer and more pleasing.

Fig. 191 shows the texture of a tapestry carpet. A and B are the ground warp threads which bind the weft, the same as in Brussels; these threads go on one warp roll. 1, 2, and 3 are the lying or filling warp threads of linen, hemp, or jute, used for giving weight and thickness to the cloth; these threads go on a second roll. P is the pile, which, it will be observed, is of various colours and looped all along the cloth, or passes over every wire that is inserted, and the pattern is formed entirely by the colours that these threads are printed. The pile goes on a third warp roll. All the pile can go on the one roll, as every thread is looped alike by each wire inserted. A pair of shafts for the ground warp—one for the lying warp and one for the pile—is all that is required for weaving the cloth. The pile consists of two or three ends of two-fold worsted yarn, according to the quality of the

carpet. As the fabric is made up to a great extent with the three lying ends of stiffened hemp or flax to each row of pile loops, the carpet is of a harder and less pliable nature, with less spring in it than a Brussels (which has the five pile worsted threads in it), and it is also less durable. The number of pile loops in the width of the cloth is the same as for a low-class Brussels carpet, say 216 to 225, and the width of the cloth is the same—about 27 in. Five threads go to each split of the reed—viz. one pile, two ground warp, and the three lying or filling ends.

In these carpets, as well as in Brussels, it will be seen from the sections that one weft thread is above a lower one, with a straight tightly-stretched warp between them. A method of weaving has been adopted on the Continent in which both sheds are formed and both wefts picked at the same time. One shed is raised above the centre warp, and one is sunk below it, and both shuttles are driven through simultaneously; then a pile shed is raised and a wire inserted; and this repeated, reversing the ground sheds, makes the order of weaving for tapestry carpets. Another method is to have double mails, one mail above the other on the same harness cord or heald; the wool warp goes to the upper mail, and the lying warp to the lower one. When the mails are raised a double shed is formed, and a pile wire and a pick can be inserted at the same time. The ground or binding warp is in two additional leaves of healds. To apply the former method to Wilton carpets, two picks are put in below to balance with the two above, instead of one pick below, as shown in Fig. 189.

For tapestry carpets the pattern is prepared in the same way as for Brussels. The repeat of the pattern may be of any length, but 27, 36, or 54 in. are usual lengths. The pattern, though prepared as if for the jacquard, is only a guide for the printer when printing the colours on the warp.

The pattern is printed on the warp in an elongated form, the amount of elongation coinciding exactly with the reduction the pile loops make in the length of the warp when it is woven.

The pattern was originally printed on the woven cloth by means of blocks; next it was printed on the warp in an elongated form in the same manner; now it is printed by means of small rollers. The yarn

for each thread of the warp, or of a number of warps, is wound separately on a large reel or drum, of such a size as will hold a suitable quantity of yarn (about $18\frac{3}{4}$ feet in circumference). Six or eight threads are wound on together, so as to lie closely together side by side and not overlap each other, till the drum is full, or the required length is wound on it. This has now to be printed with the pattern in an elongated form. *

The right-hand edge of the drum is divided into as many divisions as a length of yarn equal to the circumference of the drum will make loops on the cloth. This is called the index, and 648 is a common number of divisions for it to have, or 864 for a larger size. Of course the number of loops any length of yarn will make depends upon the size of them, and the reduction in length from the yarn to the cloth depends upon the height of the pile and the number of loops in a given space. The number of loops per inch varies with the quality of the cloth; 7 or 8 is usual for loop pile, and 9 or 10 for cut or velvet pile. The design must contain such a number of checks in length as will divide evenly into the index number, such as 108, 162, 216, 324. When painted the design is cut into strips in the direction of its length, one line or row of checks in each strip. When the yarn is wound on the drum, and the printer is ready to begin work, he takes one of these strips and pins it up before him to guide him in the colours he is to print. The printing is done by means of a trough of colour with a roller in it, set on a carriage beneath the drum, so that when passed across the roller will press firmly on the yarn. The printer finds the first colour on the design, and setting the drum to the first tooth of the rack or index, he passes a trough of the proper colour across the drum and back again; if the second check on the design is the same colour, he turns the drum round a tooth of the index and passes the same colour across; if the third check is a different colour, this requires a second colour trough, and passing another tooth on the index this colour is passed, and so on with the remainder; or, all one colour is printed first, then the drum revolved again with the second colour, and so on. When this is all printed the yarn is taken off the drum and marked No. 1 thread, and the beginning and end of

the thread should be marked in some way as a guide for the setters. A fresh lot of yarn is wound on for the second thread, which is printed according to the second strip of the design. This must be continued for all the threads in the warp. After being printed, the colours are fixed by a steaming process, and afterwards wound on bobbins and marked to their numbers. The design may be cut into strips of two checks each, instead of one check, which will be less liable to get torn. One side of the strip can then be printed first, and the other after.

The warp is made up by 'setters,' who arrange the threads together in proper order in a frame for the purpose, and set them so that the colours of each thread come together at the proper place to form on the warp a correct elongated copy of the pattern; when correct it is wound on the beam for the loom.

In printing and steaming, the colours are liable to run into each other; some colours are worse in this respect than others, but it is reduced to a minimum by the use of an absorbent in steaming; and sometimes the designer makes a little allowance on the design-paper for such colours as he knows will be liable to run and injure the pattern. The pile of tapestry carpets is usually left uncut; but sometimes it is cut, forming a velvet pile. In this case the carpet is made of a better quality, and the pile is longer.

The present method of preparing tapestry warps was invented by Richard Whytock, of Edinburgh, in 1832, and perfected by Messrs. Crossley, of Halifax.

Axminster Carpets.—Real Axminster carpets, as already said, are made by hand; much in the same manner as Turkish or Persian carpets, and attempts have also been made to produce them by machinery, several patents having been taken out for the protection of the inventions. These carpets, with other art carpets now being made, may be classed with tapestry as works of art.

The Axminster carpets of commerce are the Royal Axminster or Moquette carpets, and the patent Axminster or chenille carpets.

Royal Axminster carpets are made by a peculiar process of weaving and tufting on a loom made specially for the purpose. A number of little funnels carrying from spools threads of the different colours of

yarn required for the pattern are fixed on the loom above the reed, and these threads, by suitable mechanism, are brought down and bound into the backing cloth by the weft. These threads, which form the pile, are cut off, and afterwards the surface of the carpet is shorn level.

The texture of Moquette carpets is shown in section in Fig. 192, two varieties of texture being given, one at A, the other at B. In both these textures the pattern shows through on the back of the cloth.

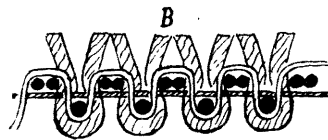
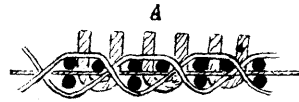

FIG. 192

Another variety is given in Fig. 193. A is the section through the weft, B the texture, C D E F shows the interlacing of each of the four warp threads in the pattern with the weft, and G shows the pile. Similar numbers in these figures represent the same threads in the cloth.

Patent Axminster Carpets.—These were invented by Mr. Jas.

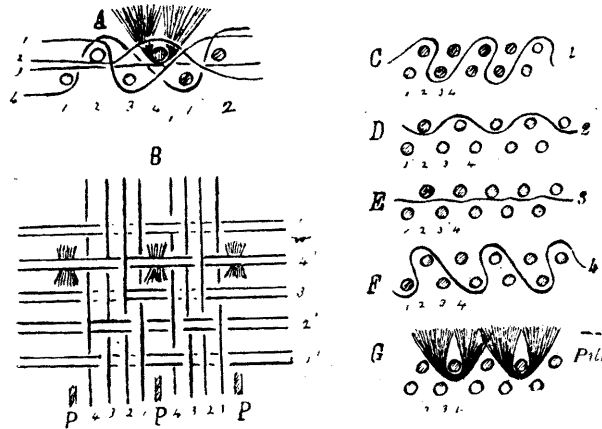

FIG. 193

Templeton, of Glasgow, about 1839, and are a description of chenille weaving. They do not require to be wrought by a jacquard any more than the other Axminster carpets, but as the figures formed on them are so similar to those produced by the jacquard, and as the method

of designing the patterns is the same for both them and other classes of chenille as it is for jacquard work, it may not be considered out of place to give a full description of chenille here.

Chenille is made by a double process of weaving. First the weft or chenille thread is woven, if for a figured pattern in various colours, which corresponds to the printing of the warp in tapestry carpet weaving, which gives a warp figure, whereas chenille gives a weft figure. When the weft is woven in a piece it is cut up into strips and twisted, if for curtains or any fabric on which the chenille weft is to show on both sides; but for carpets, where all the pile is raised to one side, the weft is doubled up, bringing all the pile in one direction. Twisting machines are now in use for making the weft for plain chenille fabrics, but for figured ones it is still woven. If twisted for figured work it would afterwards have to be printed somewhat similar to tapestry carpet warps, but without elongating the pattern, and the uneven surface is a difficulty in the way.

The method of weaving chenille weft is as follows:—A loom fixed for working gauze is supplied with a thinly laid warp, which, according to the class of chenille required, is drawn through the heddles either as plain gauze, two threads working plain with one crossing them, or this doubled, as is shown in Fig. 194. The two, three, or six threads of the draft are drawn into one split of the reed, which is finer or coarser to suit the fabric required. For shawls or curtains there would be six to eight full splits of the reed per inch; say in a reed of thirty to forty splits per inch, four splits empty to one full. For carpets there would be two or three full splits per inch; say in a reed of ten to fifteen splits per inch, four empty and one full, coarser or finer to suit the length of pile required.

For plain work this is tied up and woven as gauze, the warp being cotton of a dark colour, and the weft woollen, noil silk, or other fibre if desired; but it should consist of several ends and be of such a nature as will divide easily to form a rich pile. If for figured work, the pattern must be woven in stripes across the piece, which will be explained after the designing.

When the piece is woven it will be as shown at A, B, or C (Fig. 194)

and must next be cut into strips midway between the ribs. Sometimes this is done in the loom as the cloth is being woven, by having cutting knives arranged to divide it as it passes over the breast beam ; but it

is usually taken off in the piece and cut afterwards in a machine for the purpose. The piece is fed through rollers in the cutting machine over a grooved roller, shown at B (Fig. 195), the grooves being at such a distance apart that the ribs of the piece will fall into them. Above this roller is a set of cutting blades fixed in a spiral form round a roller ; one of these blades is shown at A (Fig. 195), with a section of the roller. The blades are set at such a distance apart that when revolving they fall into the cuts in the roller B, and running at a high speed they sever the piece into strips as it passes through the machine.

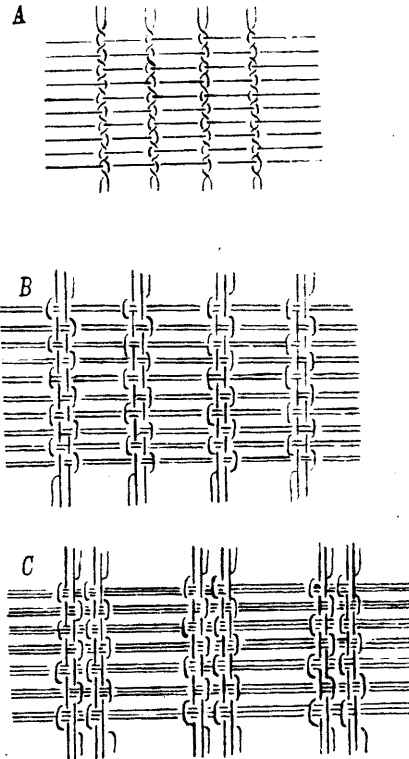

FIG. 194

So far the process is alike for all classes of chenille work.

The weft is now in strips similar to that shown at A (Fig. 196) if for carpets, and much smaller if for curtains or shawls. For ordinary chenille the weft is next twisted so as to make the projecting fibres stand out round the rib or core, and when finished it has the appearance shown at B (Fig. 196). If for carpets, the fibres are turned up so that all will project in one direction, as shown at c and in the cross-section at d. This is done by running the strips over a grooved roller, as c (Fig. 195), which is heated with steam, and as the projecting ends

are doubled up by the grooves in the roller the heat sets them in this position. The weft is now prepared, and is wound on bobbins and woven in large shuttles.

The texture for chenille is the same as for plain cloth. A fine black warp of cotton is used, with twenty to twenty-five threads per inch (more or less, to suit the fabric required), and twelve to sixteen shots per inch of the chenille weft are used, which must also be varied to suit circumstances and the thickness of the weft used. The fibres or

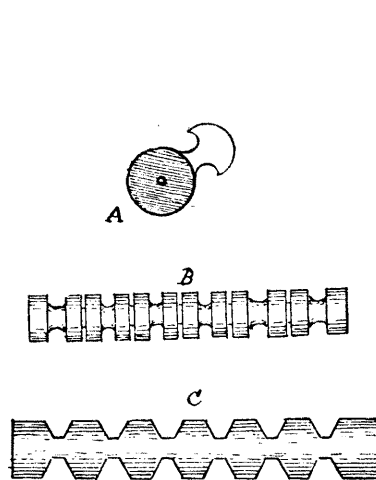

FIG. 195

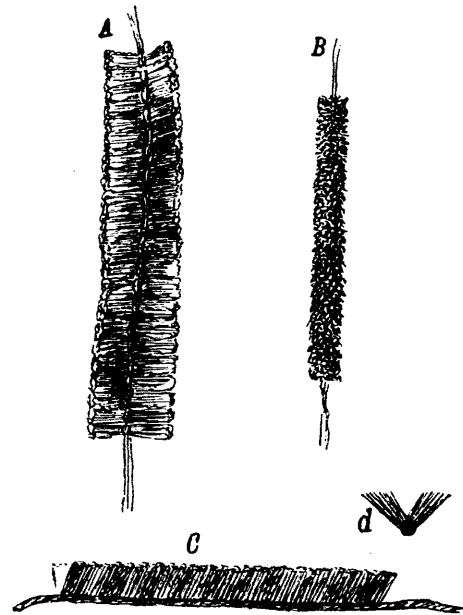

FIG. 196

points of the thread of weft project through the warp, and a pile fabric is produced which should entirely conceal the warp on both sides of the cloth. For carpets the pile is, as a rule, only allowed to project on one side, though some rugs are made with a twisted chenille weft, and the colours on it are shown partly through the backing as the fibres of the thread get mixed up with the ground or backing in weaving, but usually all the pile projects through to the face.

The texture for patent Axminster carpets is shown at A (Fig. 197),

and sections of the cloth through the weft are shown at B and C in the same figure. B is a section of the texture A with two picks between the pile or chenille picks, and C is for a coarser description of work with four ground picks between the pile picks. In A only the ground texture is given complete; the pile weft P lies over the picks *f f*, and is bound down by a fine black stitching thread *c*, which passes over it

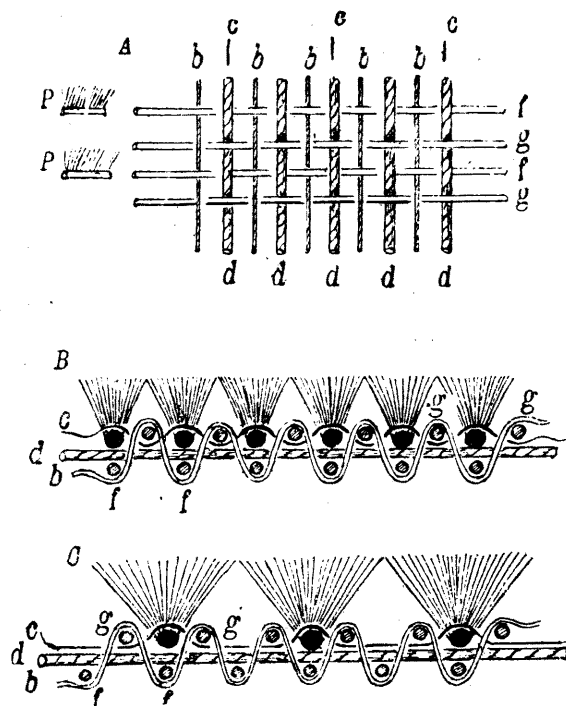

FIG. 197

and under the picks *g g*. The different thicknesses of the threads are represented in the drawing: *c* are cotton, and the others hemp, flax, or jute. There are about ten thick and ten fine warp threads per inch, and five binding threads, and about seven chenille picks per inch, with two ground picks between these. When there are four ground picks between the pile picks the pile is coarse, and only about four picks per inch are used. The chenille weft is wound on large wooden needles

like huge netting needles, about 4 ft. long, so that it may come off without any twist in it, and the weaver pushes these through the shed, laying the weft nicely in and combing it forward so as to get it straight and even and have all the pile standing upright; he then knocks in two ground picks and puts in another pile thread, as before.

This is all hand-loom work, but power looms are sometimes used for the purpose. The ground of the fabric can be woven with heddles, as before, but the binding warp threads are through needles, somewhat like gauze dents inverted, and not through the heddles; and the beam or spools containing them is above the loom in front. The chenille weft is wound on a reel, and is through a guide or carrier. When the chenille weft is to be laid in, the needles carrying the binders are raised and the guide passed along, laying in the weft. The loom stands stationary for a short time to give the weaver time to comb up the pile, and then moves on and throws in the ground picks. Everything is done automatically but the combing up of the pile.

The foregoing is a description of chenille weaving provided no pattern has to be attended to; we must now consider the pattern.

The design paper used is the same as for ordinary work, with a greater number of warp than weft threads, but it is ruled on a large scale so that the pattern will be exactly cloth size. Fig. 198 is a sample of this design-paper for seven picks per inch. The small checks, or what in ordinary weaving would represent the warp threads, have here no reference to them, nor do the warp threads require any consideration when preparing the pattern. The narrow way of the checks is a guide to the weaving of the weft threads. This paper might have been square, seven by seven, and would thus suit for such a pattern as is shown in Fig. 199—supposing seven shots of chenille weft per inch to be correct; but there is an advantage in many cases to have it as it is, or even more off the square, say seven by twenty, which is one of the papers used. This will be most readily understood by following the working out of the pattern.

The pattern given (Fig. 199) is necessarily very simple for want of space. The different markings on the squares are to indicate different colours. Here nine are used, but there may be any number

—say from eight to twenty—the only restriction on the number of colours employed is that so many shades of yarn are required to match them, and that the weaver has a greater number of shuttles to pass over when weaving the weft. When the pattern is painted it is cut cross-ways into strips, as A, B, two rows of checks in each strip; one row of checks may be in each strip if desired; but this is unnecessary, and besides, they are more easily torn. These strips are a guide to the weaving of the weft, just in the same way as the pattern in tapestry carpet work is a guide to the printer.

The weaver takes a strip of the pattern and puts it through a widened

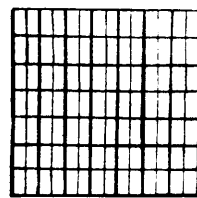

FIG. 198

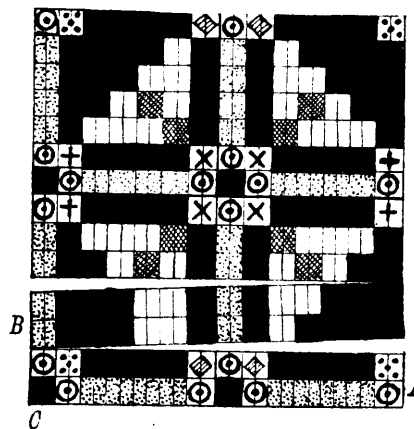

FIG. 199

split in the reed and pins one end of it to the cloth; to the other end he attaches a cord and light weight, which he hangs over the back rail of the loom so that the strip of design will be held steady and move forward as the cloth is drawn up. The strip must be pinned to the cloth so that the first check of the design projects over the fell of the cloth. Suppose the strip to be A, Fig. 199: c is the first check; the weaver sees that this is black, and proceeds to weave the gauze with black weft for the length of this check (one-seventh of an inch). The next check, moving along the strip in the loom, or from left to right on the design, is a different colour, say scarlet; the weaver changes his shuttle and weaves as many checks as there are of this colour, which

in this case is only one. Another change of shuttle is made, and so on till the end of the strip is reached ; it is then turned, the other end of it being brought to the fell of the cloth, and the checks on the second line of the design are woven in order as before, only they must run from right to left on the design instead of from left to right, as the first line did, which will be caused by the turning of the strip of paper ; for it must be borne in mind that if the first shot of chenille weft is put into the carpet from left to right, the next one will be put in from the reverse side or from right to left, so that all the odd numbers of lines on the design-paper should be begun by the weft weaver at the left-hand side, and all the even numbers at the right-hand side, provided the weaver works in this way ; in any case one must be the reverse of the other. When all the strips of the pattern are woven, each rib of the piece of weft will be long enough to weave as many shots as are in one repeat of the pattern, and if there be 40 ribs in the piece, it would, when cut up, furnish weft for 40 repeats of the pattern. For weaving this weft large needles are used, somewhat similar to netting needles, which are about 4 ft. long for wide looms ; the chenille is wound on these, free from twist, and must be put on so that it will come off correctly to suit the pattern. The strips of chenille are marked to show which end is to be put on the needle first. These needles are pushed through the shed by the weaver when weaving the carpet—put in at one side and drawn out at the other. He lays in the weft as correctly as possible, combing it up to the fell of the cloth, and makes the colours fall in nicely together, drawing it tighter or leaving it slacker as is necessary. Now the advantage of using the special design-paper will be more readily understood. It is plain that if 14 by 7 design-paper be used, instead of 7 by 7, any of the colours may be changed in $\frac{1}{4}$ in. on the design ; and also in the chenille weaving, when it is desirable to do so, instead of in each $\frac{1}{2}$ in. when 7 by 7 paper is used. And if 20 by 7 paper were used, the changes might be still more frequent ; besides, in flowing patterns the advantage also comes in to assist in getting the forms more correct, in the same way as paper over square in either warp or weft assists in getting the form of the figure in damask designing over that where only the coarser way of the paper

square is used ; though the effect is not by any means so satisfactory as if the paper were finer both ways, and square. Yet when one way is fixed by circumstances it is in many cases preferable to alter it in the other way than to leave both alike coarse ; but not always so, as, for example, the pattern given in Fig. 199. When these carpets are woven they are passed through a shearing machine, which makes the surface of the pile quite level. They are rich handsome carpets, as well as very durable.

CHAPTER XI

LAPPETS AND SWIVELS

Lappet and Swivel Weaving.—The only classes of figured weaving of any importance not already mentioned are lappet and swivel work, both of which are very limited, but produce good effects. With lappets, figures can be put on light fabrics without requiring any cutting off of the surplus yarn. It is principally in the muslin trade that they are used, for figuring Indian fabrics with gay colours. The principal seat of the manufacture in this country is about Glasgow. The figure is formed by an extra warp drawn through one or more frames of gauzing needles set in the lay in front of the reed, which can be moved to either side as desired. The pattern is cut on a large wooden wheel or disc, in the face of which a groove is cut to form the pattern, and a traveller working in this groove, and connected with the needle frame, slides the needles to either side and stitches the figuring warp into the cloth, the needles rising and falling as the cloth is being woven. The figure is rather loose and only suited for simple effects. A description of the process of working can be found in Murphy's or Gilroy's works on weaving, and is interesting, though rather out of date. Swivel work is of a much better class, though not so suitable for getting small figures, as spots short distances apart. But it gives a much better bound figure—in fact, it may be bound in any way—and is very suitable when a few are required on the fabric, such as crests, or any figures in the corners or centres of handkerchiefs, napkins, etc. These are weft figures and usually of a different colour to the ground of the fabric, which may be either plain or figured. These figures could be formed with an ordinary box loom, cutting off the loose weft or binding it up to the ground cloth;

but the latter is useless for light fabrics, and the former leaves the figure unbound round the edges. If the figure is large enough it can be made in an ordinary check or pick-and-pick loom, and bound as with swivels. The swivels are small shuttles similar to those used for weaving silk book-markers and such like fabrics, and are usually attached to the hand rail of the lay of the loom. The swivel attachment is fixed so that when a shed is opened the shuttle falls to pass through it, or a second high shed may be opened for the swivel shuttle. The shuttle is driven by means of a rack and pinion, the former being in the shuttle, and the pinions fixed to revolve in the frame. When the pinions are revolved the shuttle is drawn across. The breadth of the figures must be considerably less than the length of the shuttle, so that for large-sized figures this method of working is not suited.

CONCLUSION

Since the foregoing was written up to the present time (Sept. 1894) nothing new worth describing has made its appearance. A few card lacing machines have been brought out and several patents have appeared in print, but most of these disappear shortly after.

No mention has been made in this work of Count Sparres' patent card-cutting machine, which was to have done away with the necessity of putting patterns on point paper by cutting the cards direct from the sketch embossed on a metallic plate. This was a highly ingenious machine, and under suitable conditions produced very fair work, but so far it has proved rather expensive to the company that took it up.

Another process to obtain similar results, patented by Messrs. Dawson and Adams of Macclesfield, was described in the 'Textile Manufacturer' in 1893. In this process a perforated plate is filled with small pins; a piece of strong paper is laid over this, and over the paper another plate. The pattern is formed by pushing the pins through the paper between the plates. A large portion of this work can be done by mechanical means. When all the pins required for the pattern are pressed through the paper, the top plate with the sheet of paper is turned upside down, the pins sticking in the paper. By run-

ning a roller over the paper the pins can be pressed out of it and into the plate. This plate is then put into a reading and punching machine, and by suitable mechanism the pins can be brought to act on either a card-punching apparatus or on the harness of a pattern loom; so the manufacturer can have a sample of the cloth woven without any cards and can have the cards cut for the factory loom afterwards if he requires them. The cards can be punched at the rate of 2000 per hour.

By means of a pattern cut out of a plate of wax, and a reading in machine, the filling of the pins into the plate, or the hand reading as it is called, can be dispensed with.

It has since been stated that this firm are now trying to perfect a process which was tried thirty years ago, viz. to paint the pattern with electric paint which is to act on needles charged with electricity.

These are all highly ingenious inventions, and are interesting to those who do not lose too much by them; but it will require a nice machine to produce all the variations in a pattern that an experienced designer can, though in many patterns this could be dispensed with, and suitable mechanical means may yet be devised to take a share of the work.

INDEX

- AXMINSTER carpets, 266, 288
- BARREL or cylinder loom, 17
Beating a harness, 89
Bessbrook machine, 185
Border design, 97, 100, 115, 134
-- mountings, 105
Bouchon's loom, 18
Brussels carpets, 276
- CARDS, 51, 147
Card cutting, 139
-- -- machines, 143
-- -- -- (Count Sparres'), 299
-- -- -- (French), 167
-- frames, 47, 156
-- lacing, 139
-- -- machines, 148
-- repeating machines, 149
Carpets, 264
-- chenille, 290
-- Axminster, 266, 288
-- Brussels, 276
-- Indian, 265
-- Ingrain, 269
-- Kidderminster, 266
-- patent Axminster, 289
-- Persian, 265
-- royal Axminster, 288
-- Scotch, 266
-- tapestry, 285
-- Turkish, 265
-- Wilton, 284
Centred tie, 97
Chenille, 290
Comb draw loom, 16
Comber boards, 82, 103
Cross-border jacquard, 155
Cross's counterpoise harness, 14
Cumber boards, 82, 103
Curtains and tapestries, 248
Cylinder motions (horizontal), 44
-- (self-acting), 36
-- (slide), 43, 57, 61
-- (swing), 33, 56, 58
-- to set a, 40, 43
- DESIGNING and draughting, 110
-- hints on, 120
Design paper, 112
-- to prepare a, 115
Designs, 94, 97, 100
-- for dress goods, 122
-- for gathered borders, 97
-- for single borders, 100
-- (repeating), 94, 122
-- (texture), 124
Double cloth, 233
-- -- jacquard, 241
-- warp faced cloth, 237
-- weft faced cloth, 235
Draughting a pattern, 115
Draw loom, 3
-- -- French, 24
Drawing in a warp, 99
- FALCON'S loom, 19
French card, 51
-- -- cutting machine, 167
-- draw loom, 24
-- jacquard, 49
Full harness, 69
-- -- mountings, 69
- GATHERED tie, 97
Gauze, 196
-- to design a pattern, 215
-- harness (hand-loom), 203
-- -- (power-loom), 205

- Gauze, jacquard, 214, 223
 — patterns, 197, 198, 217
 — reed, 225
 Griffes, 37, 52
- HAIR-line patterns, 129
 Half-harness, 69, 169
 Harness, drawing warp into, 99
 — illustrations of, 96, 98, 102, 191
 — to prepare a, 71
 — to tie up a, 87
 — (double cloth), 233
 — (full), 69
 — (gauze), 203, 205
 — (half), 69, 169
 — (muslin), 169
 — (pressure), 70, 174
 — (quilting), 233
 — reeds, 82
 — (split), 62, 172
 — twine, 75
 Hecks, 77
 Hole board, 83
 Hooks for jacquard, 38, 39, 52, 59
 — in double-acting jacquard, 55, 59
- INDIAN carpets, 265
 Ingrain carpets, 269
 Introduction, 1
- JACQUARD'S machine, 23
 Jacquard machines, 27
 — (cross-border), 155
 — (double-acting), 52
 — (double cloth), 241
 — (double-acting with two cylinders), 58
 — (French), 49
 — (gauze), 214
 — (Karl Wein), 192
 — (leno), 214
 — (open-shed), 161
 — (quilting), 241
 — (twilling), 185
 — (Verdöl), 163
 — cards, 50
 — cylinder, to set a, 40, 43
 — hooks, 38, 39, 52, 59
 — interior of, 38
 — needles, 38, 39, 52, 59
 — shedding, 60, 62
 — stop motion, 64
 — to set a, 43, 46, 76
- KARL WEIN jacquard, 192
 Kidderminster carpet, 266
- LACING cards, 139
 — machine, 148
 — twine, 147
 Lappet weaving, 298
 Lashing a pattern, 9
 Leno jacquard, 214
 Letters, mottoes, &c., 136
 Levelling frames, 85
 — the mails, 86
 Lingoes, 72, 74
 London tie, 96
- MARKING off a cumber board, 103
 Marseilles quilt, 246
 Matelasses, 246
 Mottoes and letters, 136
 Mountings, 69
 Muslin harness, 169
- NECK of harness, 79
 Needles, 38
 Norwich tie, 95
- OPEN-SHED jacquard, 161
- PAINTS for patterns, 116
 Parrot machine, 11
 Patent Axminster carpet, 289
 Pattern, to draught a, 115
 Patterns (carpet), 280, 282-3
 — (gauze), 197, 217
 — (hair-line), 129
 — (spot), 130
 — (texture), 124
 Persian carpets, 265
 Piano machine, 145
 Pile work, 259
 Point paper, 112
 Poplins, 252
 Pressure harness, 174
- QUILTING, 247
 Quilting harness, 233
- READING a pattern, 9
 Repeat of a pattern, 94
 Repeating machines, 149
 Reversing motions, 45
 Royal Axminster carpets, 287
- SCOTCH carpets, 266
 Set of harness (to vary), 106

- Setting a jacquard, 43, 46, 76
Shading floral forms, 118
Shedding of jacquards, 62
Simple (draw loom), 3
Slabstock, 85
Sleepers, 73
Slips (comber board), 83
Split harness, 172
Spot patterns, 131
Spring box, 42
Stop motion, 64
Suggestions on design, 120
Swivel weaving, 298
- TAIL cords, 54
Tapestry (real), 255
— carpets, 285
— curtains, 248
Terry pile, 260
- Texture patterns, 124
Tie of a harness, 93
Trap board, 15
Turkey carpets, 265
Turkish towels, 260
Twilling designs, 117, 133
— jacquards, 185
Twill for damask, 181
Tying up a harness, 87
- VARNISHING a harness, 92
Varying the set of a harness, 106
Vaucanson's loom, 22
Verdöl jacquard, 49, 163
- WILTON carpets, 284
Wiring cards, 153
Woollens and worsteds, 248