

PLATE XXIX.

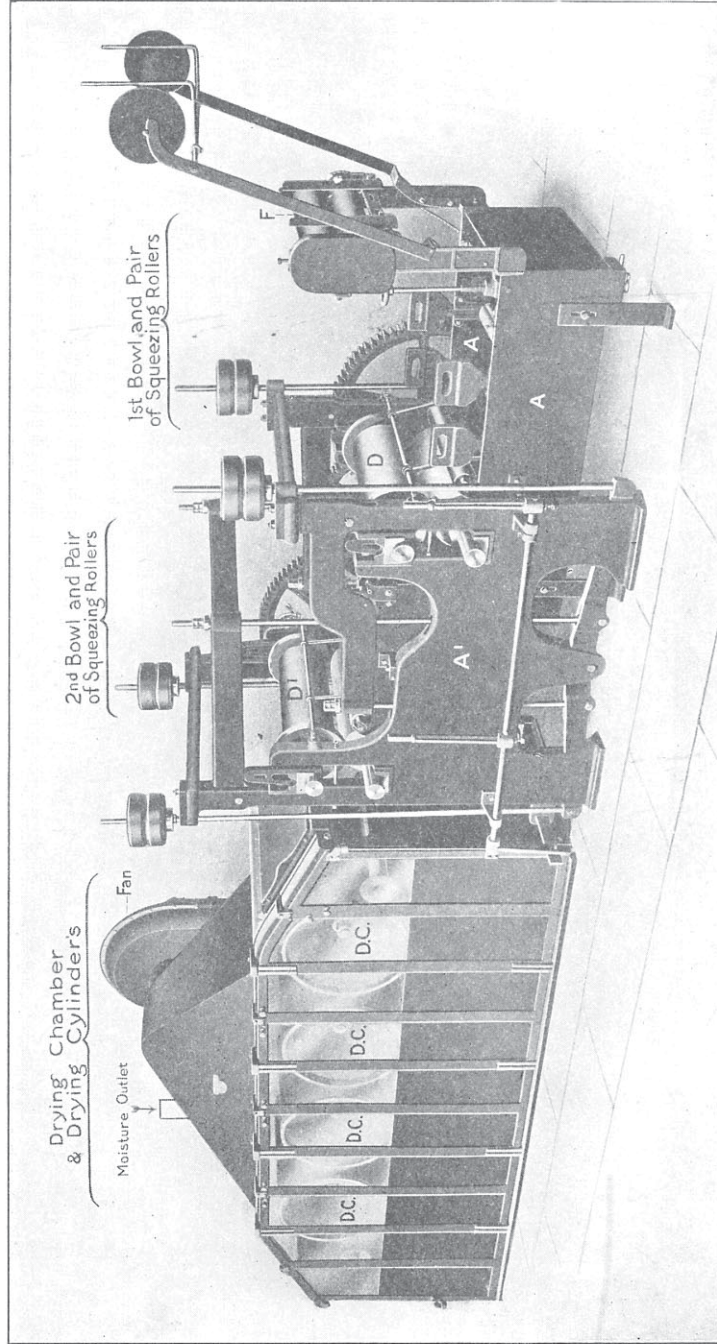

FIG. 95. WHITEHEAD AND LEYLAND'S BACKWASHER.

69. *Backwashing*.—After carding, the material is ready for those processes which belong strictly to worsted yarn manufacture, namely, backwashing, combing, filling, drawing, roving and spinning on the cap or flyer-frame. Backwashing is the first of these processes. The material, as it leaves the carder, may be somewhat discoloured by the oil applied to facilitate its passage through the machine, and also contains some dirty matter. It is necessary before combing, to remove such impurities, and thoroughly cleanse the cardings. This is done in the backwashing machine (Fig. 95), to which is attached a double screw gill balling-head. The machine consists of a couple of cleansing bowls, A, A^1 , each of which possesses a pair of immersing rollers, c, c^1 (Fig. 95*a*), and a pair of squeezing rollers, D, D^1 , of a series of drying cylinders, D, C (Figs. 95, 95*a*), and of the gilling and balling apparatus. The carded laps—some 24—are directed between the guide to the first bowl, between the “immersers,” to the squeezing rollers, D , leaving which, the material enters the second bowl, where the process of immersing is repeated, and the scour completely pressed out of the slivers by passing between the second pair of squeezing rollers, D^1 . A washing or scouring soap, without any excess of alkali, is used in the first bowl, the standard temperature of the scour being 110 degrees. After using it is run to waste, and the solution from the second is conveyed into the first bowl, and renewed as required with the scouring ingredients employed. If the sliver should be tinged yellow, a “blueing” or “tinting” solution to improve the whiteness of the wool is added in the second bowl, which is chiefly utilized for rinsing purposes.

In the old type of the backwasher, the carded slivers from bowl A^1 , Fig. 95*a*, after passing between squeezing rollers D^1 , were taken round drying cylinders heated with steam. This was a defective system for three reasons; first, it scorched the material nearest to the surface of the cylinder and resulted in irregular drying; and second, it left the material harsh and in a more or less unsatisfactory

condition for gilling; and third, it had a tendency to discolour the wool.

On the modern machine (Fig. 95, Plate XXIX) the drying cylinders are in an enclosed chamber. The cylinders are some seven in number, and twenty-four inches in diameter, with twenty-five and a half inches width of drying surface, and made of brass and perforated. Hot air is generated from a series of upright steam pipes placed between the two frame sides and along the rear portion of the machine. It is circulated through the cylinders by the fan shown which makes some 1,600 revolutions per minute. Such portions of the cylinders not covered by the slivers being dried, are suitably incased, effectually preventing the heated air escaping through the perforations of the cylinder without passing through the wool.

To effect economy in utilization of the hot air generated, the moisture given off in drying is carried away by the pipes M connected with a sliding valve for regulating the degree of dampness.

Leaving the last drying roller, the backwashed material is conveyed to the screw gill balling head, and delivered in two slivers on to two balls.

Backwashing on this mechanical system, namely, drying at a low temperature and forcing the heated air through the slivers as described, results in a better condition of the wool, with the colour purer and not impaired, and the lustre improved.

70. *Gilling (for Factory View of Gilling Machinery, see Plate XXX).*—The object of this process is to straighten the fibres, draw out and level the carding (Method II, page 182), and prepare the material for the combing machine. In the treatment of long wools (Method III) it is the process which results in arranging the fibres of the wool, without other preparatory mechanical operations, in a suitable condition for the comb.

A set of preparing boxes for Lincoln, Leicester, and similar classes of wool, comprises five or six machines similar to each other in construction, and also in principle of

PLATE XXX

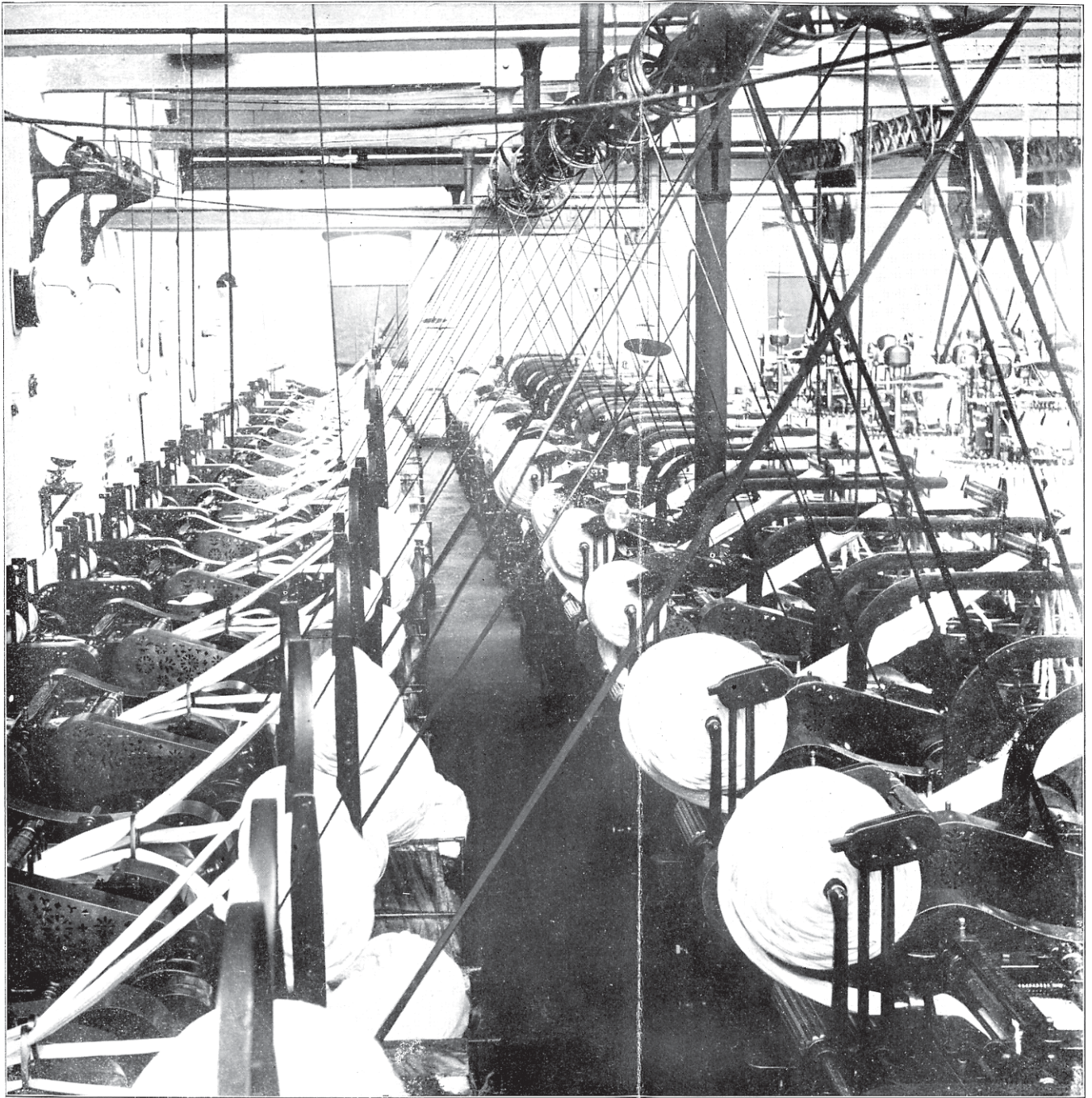

[Per Messrs. Taylor Wordsworth and Co., Ltd.]

FACTORY VIEW OF GILLING PLANT OF MACHINERY, SHOWING SCHEME OF ARRANGEMENT AND DRIVING.

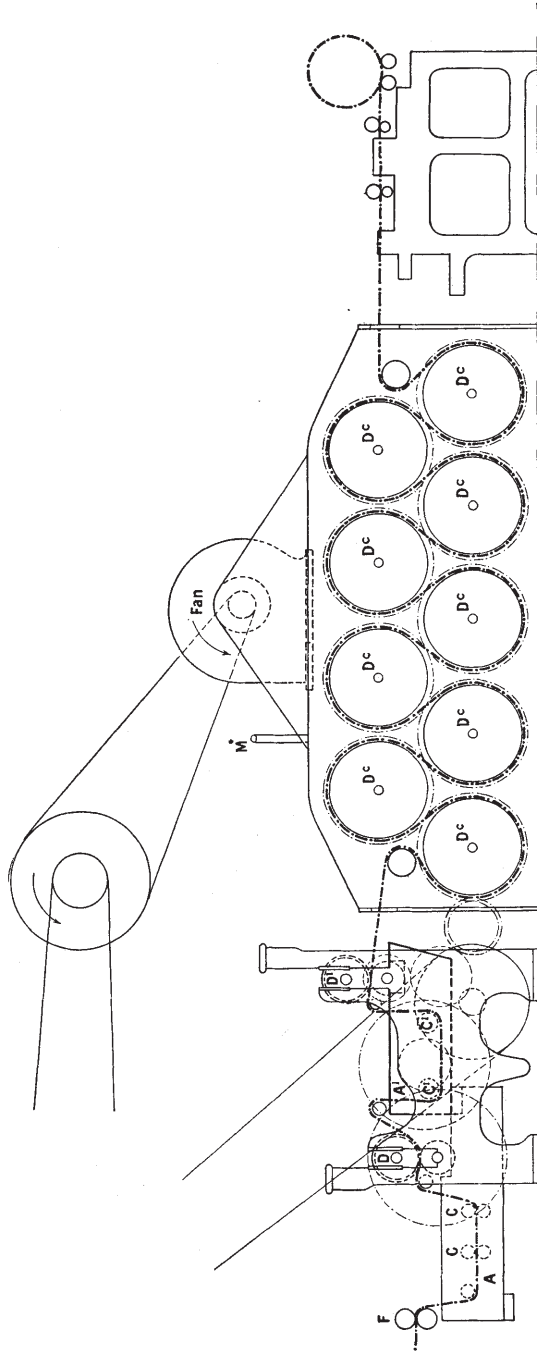

FIG. 95a. Whitehead and Leyland's Hot-air Backwasher.

C C = Immersing rollers.

D D' = Squeezing rollers.

D C = Drying cylinders in enclosed chamber.

operation, the lap of fibres resulting from first gilling after being passed through the second box, is delivered in a lap condition. In the third box, a change is made in the mode of delivery. The gilled material is passed through a metal oval piece and then between a pair of smooth pressure rollers to be delivered in the sliver form into cans. Some six of such cans are placed behind the fourth box, and the six slivers drawn out to approximately

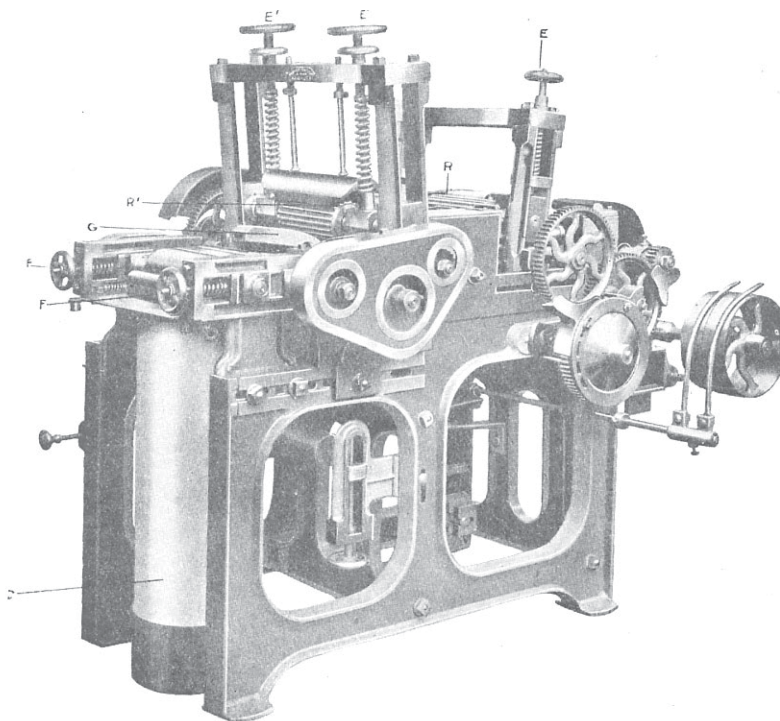

FIG. 96. Single-headed Can Gill-Box.

the thickness of one of the series. A like number is similarly re-drafted and reduced in the fifth box, and the process repeated in the next box or the sixth operation. It will be evident that this frequent combination and drawing out of the material must produce a level and uniform band or sliver of straightened fibres of a suitable character and composition for the process of combing.

For *short staple wools*, fine merinos, and cross-breds, gilling is practised both before and after combing.

Attached to the backwasher is a gill-box capable of delivering the slivers either on four balls or into four cans, and made with two sets of faller screws. Following this levelling treatment the balls of backwashed cardings or slivers are passed through a pair of gill boxes, known as preparers or intermediates, being used between backwashing and combing. One such gill-box, with one set of screws, is equivalent in turn out to four Noble's combs, each of which, on fine wool, has a productive power of 375 to 420 lb. of combed top per day of 10 hours. If the preparers are mounted with two sets of screws and fallers they are capable of maintaining the running of six combs.

The essential parts of a gill-box are the receiving and

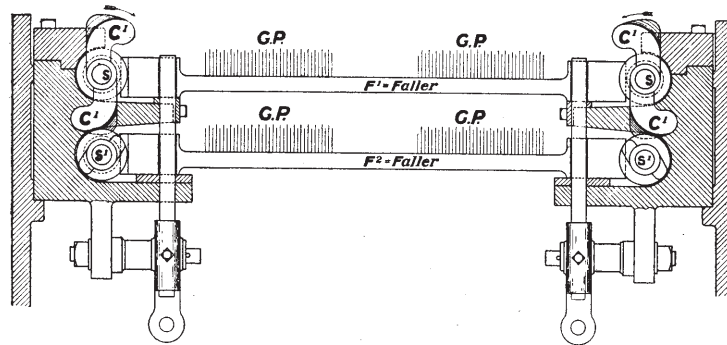

FIG. 96a.

delivery rollers R and R^1 (Fig. 96); the fallers, mounted with the gill pins, and the upper and lower screws, s and s^1 (Fig. 96a), on which the fallers travel from one end of the box to the other alternately.

Fig. 96 is a view of a single-head can gill-box. Rollers R first receive the wool, which is forcibly drawn through the pins of the fallers by the more rapidly revolving delivery rollers R^1 . In addition the fallers are carried forward on the upper screws s (Fig. 96a) at a quicker rate than the slivers are delivered into the box by the front rollers R . Reaching the end of the traverse the fallers are automatically operated upon by cams which knock them on to the lower screws s^1 , moving to the end of which—or the feed end of the box—they are automatically replaced on

the upper screws by cams c^1 . The lower screws are coarser in pitch than the upper set, usually in the preparers, on fine wool, fourteen fallers on the top screws to seven fallers on the bottom screws, each with two rows of pins (GP, Fig. 96a) and ten pins per inch. After combing, such a gill-box in preparing the top slivers for drawing, might be mounted with sixteen fallers up and eight down, with two rows of pins sixteen per inch. Necessarily, when the fallers are moving on the top pair of screws, the slivers are drafted and straightened by the difference in the speeds of the two sets of rollers R and R^1 (Fig. 96), and by being

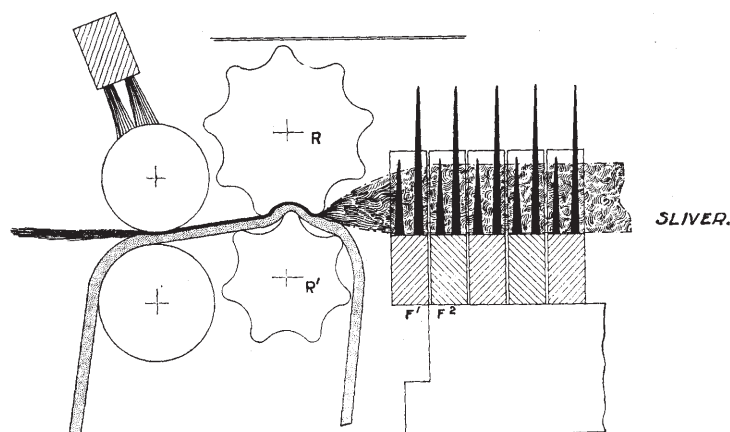

FIG. 97.

drawn between the gill pins (Fig. 96a), but their action is suspended as they return to the receiving end of the box on screws s^1 .

In ordinary gilling and drawing boxes the pressure on the drafting or fluted rollers may be regulated by hand screws, E E^1 , and on the feed or drawing in rollers by the hand screws F (Fig. 96).

In the Offerman and Prince Smith (O. P. S.) gill box each faller consists of two rows of pins of different heights. The front row is round pins and of a similar size to those in an ordinary Intersecting Gill, but the back row of pins is flat, offering the same degree of resistance to the passage of the wool as the shorter pins of the front row. The

difference between the two sets of pins is about equal in thickness to the ribbon or sliver of wool as it approaches the nip of the rollers, R, R^1 .

In the first sectional drawing of this description of gill-box (Fig. 97), the wool is shown as passing through both series of pins of the complete set of upper fallers; in the second drawing (Fig. 97a), the front faller, F^1 , has dropped on to the first step taking the shorter row of pins out of the wool, and leaving the longer pins in action; in fig. 97b F^1 has advanced towards R, R^1 , the longer pins still remaining in the wool and following the line of the sliver.

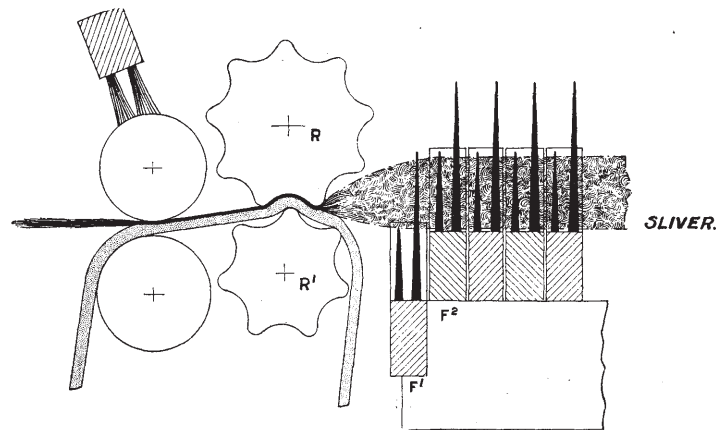

FIG. 97a.

Fig. 97b shows F^1 reaching the end of its traverse, the pins being in close proximity with the rollers and the faller about to drop on to the lower screw and allow of F^2 taking its place.

This system of gilling is said to have mechanical advantages over the ordinary system, reducing the percentage of noil waste in combing, and giving increased production, combined with a more satisfactory levelling of the slivers.

71. *Combing*.—There is a twofold object to be attained in combing, first, to thoroughly adjust the fibre in parallel form; and, second, to remove the short, curly filament present in the wool. Gilling produces a fairly level ribbon,

but it is composed of crimped and straight, and also of short, curly fibres. "Neppy" and wavy filaments, until straightened, are unsuitable for worsted yarn construction. Hence the material in the combing operation is divided into two classes, the levelled and parallelised fibres forming the "top" or "combing"; and the "neppy" fibres composing the "noil." By gilling a level ribbon of wool is obtained, but to form the basis of a smooth, lustrous, worsted thread, something more is essential—such fibres as escape or resist the action of the gill-pins, and the straightening effect of the pins of the combs must be extracted, consequently one

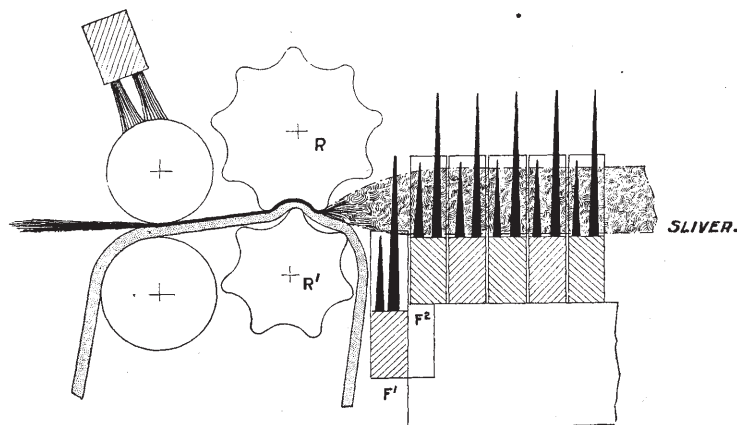
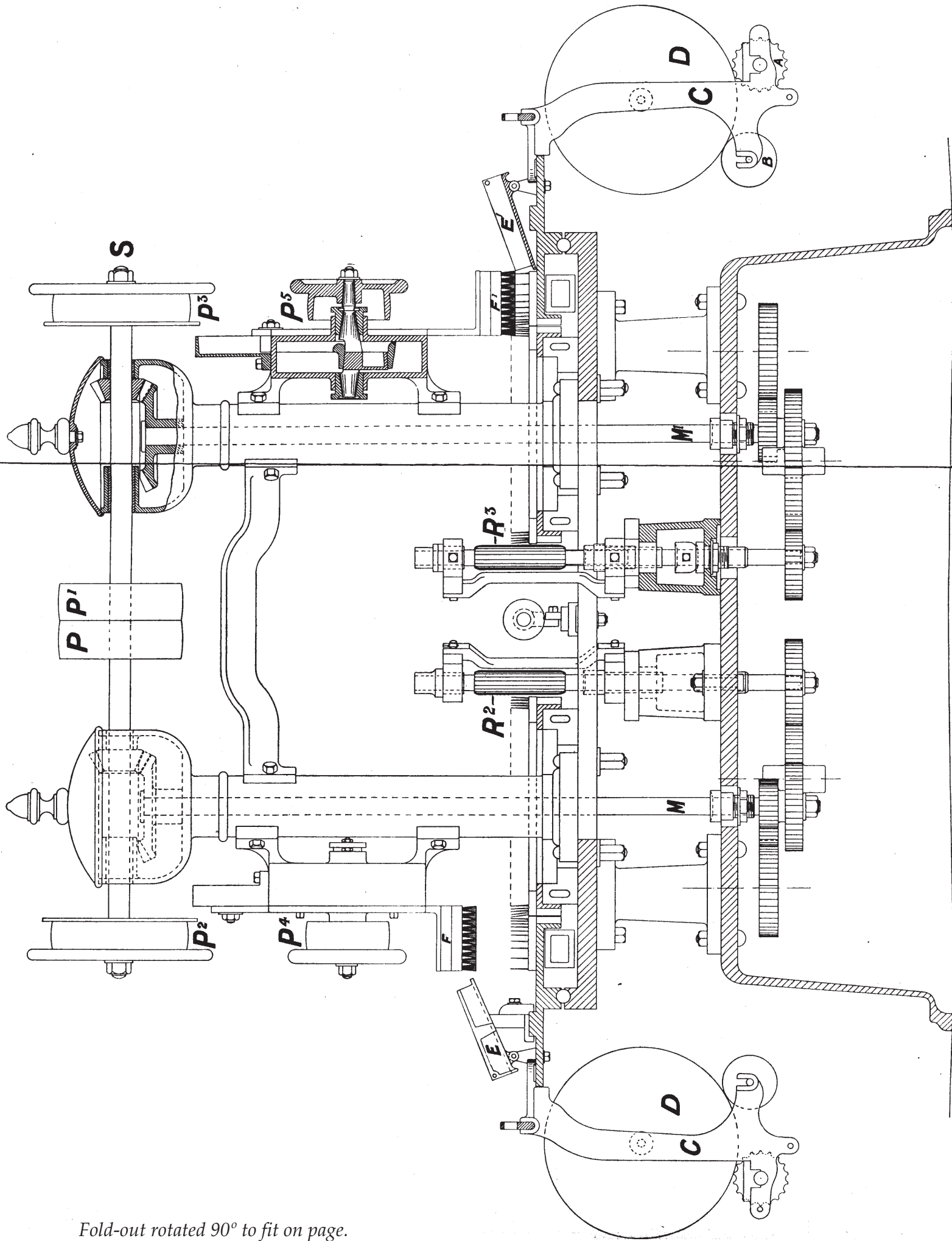

FIG. 97b.

of the main functions of the combing machine is that of separating the short, neppy and minute curly clusters of fibres from those which in the operation are arranged in a straight and regular line with the length of the sliver or "top" produced.

COMBING MACHINES (*Plate XXXI, sectional drawing of Noble's Comb, and Plate XXXII, Factory View of Plant of Combing Machinery.*—The principal types are the "circular," the "nip," and the "square motion." On the Continent the "rectilinear" comb, constructed on the principle of the mechanism invented by Heilman, and used in cotton combing, is preferred, being better adapted for the treatment of short wools from about an inch in length than machines of the English construction.



Fold-out rotated 90° to fit on page.

The circular or Noble's comb is the most extensively employed in preparing short and medium staple wools by English combers. The ribbons or slivers of wool from the second gill-box are wound on bobbins in fours on the balling machine. Eighteen bobbins are placed in the circular creel, *c*, of the comb, Fig. 98, Plate XXXI, and rest on rollers, *a* and *b*, the former being positively driven and turning the bobbins by friction, giving off the same length of sliver to each revolution of the circular frame or creel in which they are fixed. Each of the four slivers on the bobbins is passed through a separate feed box, *e*, Figs. 98 and 100. All the boxes are of the same dimensions, and so constructed that they are open at the back, being hinged to allow the lids to compress or nip the slivers and prevent them falling backwards.

The machine is driven off the pulley, *p*, Fig. 98, keyed on to the centre of the horizontal shaft, *s*. By bevel wheel gearing motion is imparted to the two upright shafts, *m*, *m*, which, by ordinary wheel gearing, Figs. 98 and 99, communicates motion to the various parts of the comb. Wheels 20, on shafts *m* and *m*¹, Fig. 99, are the draft change wheels, and effect: (1) the driving of the large circle gearing with intermediates 42, carriers 50, mounted with driver 10, gearing with the large circle wheel 264; and (2) the driving of the small circle gearing with intermediates 42, carriers 50, mounted with drivers 13, intermediates 16, with driver 12, gearing with the small circle wheels 80. Wheels 48 effect the driving of the drawing-off rollers through intermediates 80 and 72, the latter driving the wheel 40 on each of the drawing-off roller shafts.

The dabbing brushes, *f*, *f*¹, Fig. 98, Plate XXXI, are controlled by eccentric mechanism driven by straps passing round pulleys, *p*² and *p*⁴, and *p*³ and *p*⁵. They rise and fall alternately, operating at a high speed, and may make up to 1,000 strokes per minute. In Scriven's invention steel pressure blades, *k*¹, Figs. 100 and 102, are employed fixed between the combs of the two circles, and also a pair

of metal pieces, κ^2 , for guiding the material under the blades, which are operated rapidly up and down, but not lifted out of the combs. The object in both types of mechanism is the same, namely, to effectually press the wool between the teeth of the comb of both the large and small circles.

The interior of the machine, Figs. 98 and 99, where the

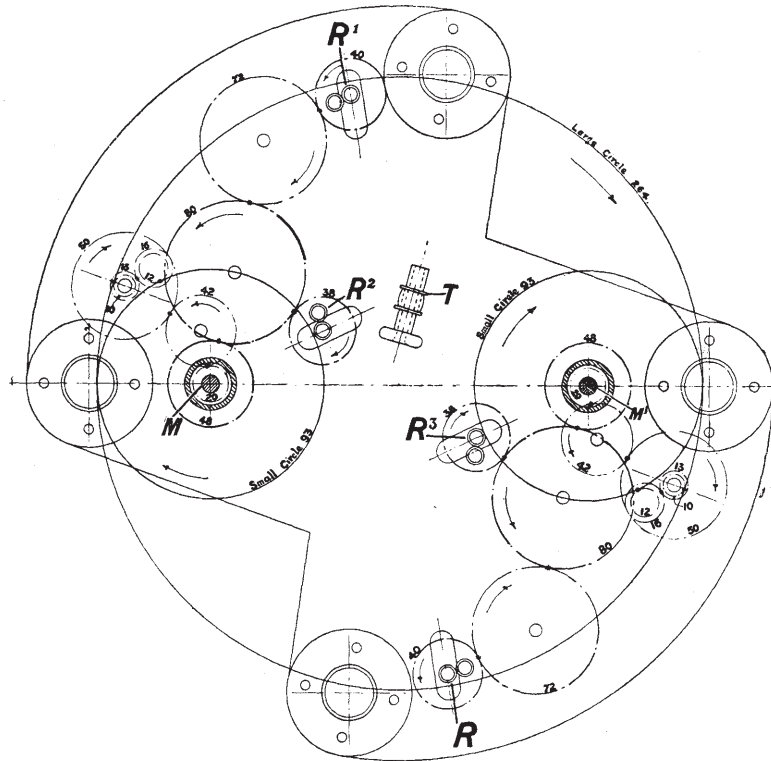

FIG. 99. Plan of Circles and Driving Gear of Noble's Comb.

actual combing is done, consists of three circular combs and of a number of vertical drawing-off rollers. The large or main circle is 48 or 60", and the small circles are 16 or 20" in diameter. The three combs—underneath which is a steam chest to heat the wool and facilitate combing—along with the creel, boxes and bobbins, revolve together and in the same direction. The wool is, in the first place, combed by being stretched between the pins of the main and small combs, and, in the second

place, by being drawn through the pins of the combs of the two circles by the drawing-off rollers.

The material is drawn into the machine from the feed boxes at the points where the large and small combs are

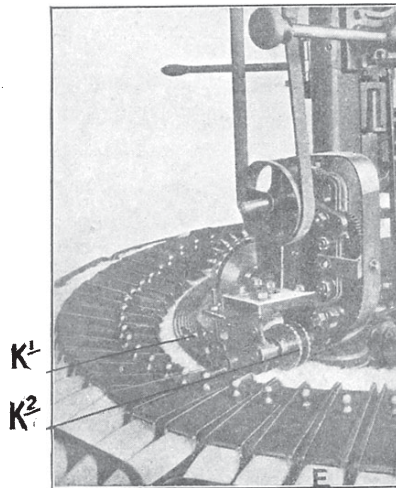

FIG. 100.

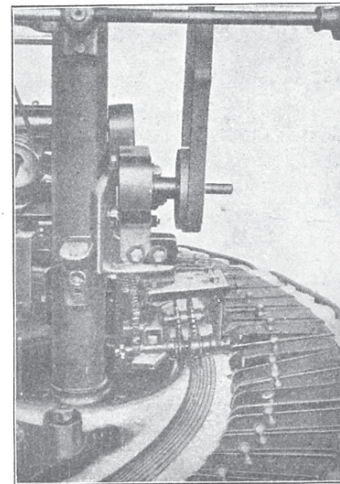
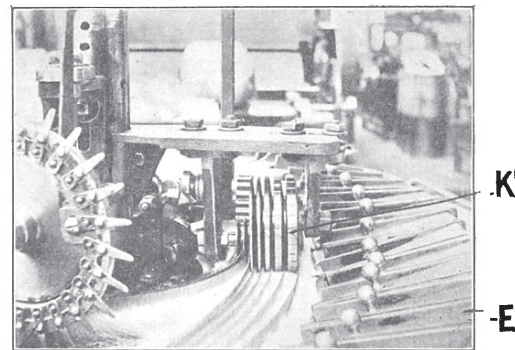

FIG. 101.



A

C

FIG. 102.

Sectional Views, Noble's Comb.

nearest to each other, and is immediately pressed between the pins of each circle by the dabbing brushes, r and r^1 , Fig. 98. Both combs carry off a part of the wool received. As the space between them increases the fibres are gradually straightened, Figs. 101 and 102, by the combing process.

of the two contending circles. In the case of the main comb the wool forms a continuous fringe on the inner edge, but in that of the smaller combs it hangs on the outer edge. Operating on the stretched filaments, and for directing the fibres as they are thus drawn out or extended between the combs of the two circles, is the *stroker* or *divider*, A, Fig. 102, a revolving part with projecting adjustable pointed pieces. The action of A is to equalize the lengths of fibres removed by each comb, dividing the material at a point equi-distant from the pins of the large and small circle. It also facilitates the function of the drawing-off rollers, $R R^1$ and $R^2 R^3$, Figs. 98 and 99, by stroking the fibres downwards and preventing them from projecting irregularly from the combs. The material hanging on the inside of the large comb, along with the fibres on the outside of the small combs, form the "top," and the short filaments remaining in the small circles are removed by steel blades or knives, and constitute the "noil."

The routine of the process may be followed by reference to Figs. 98 to 103. Fig. 103 is a section of the large circle showing one pair of drawing-off rollers, R, R^1 . The opposite side of the comb, and each small circle also possesses a similar pair of rollers. Each pair of rollers is set in close proximity to the combs, and draws off the fringe of fibres as it is formed between the combs of the two circles. The strap, s, one for each pair of drawing-off rollers, guides the fringe of combed fibres to the nip of the rollers to be combined with the second sliver from the opposite side of the circles, and also with the two combings from the small circles. The fibres remaining in the combs after passing $R R^1$, Fig. 103, are lifted out by knives set between the pins, passed over a surface plate, to be again forced betwixt the pins of both circles. As the circle, c, revolves, the parts, K^1 , Fig. 102, lift the wool not drawn off by $R R^1$ out of the comb, when it is conveyed by the revolving circle over the surface plate, f, Fig. 100, fixed in front of each dabbing brush, to be

replaced with a supplementary length of slivers drawn at this juncture into the machine, on the of the respective circles. By this arrangement the large circle is twice cleared at each revolution (once immediately before it reaches each dabbing brush), and a fresh supply of wool is also fed to the combs. This is effected by the feed boxes, E, Figs. 98, 100, and 101, revolving on an inclined plane at definite points in the circumference of the large

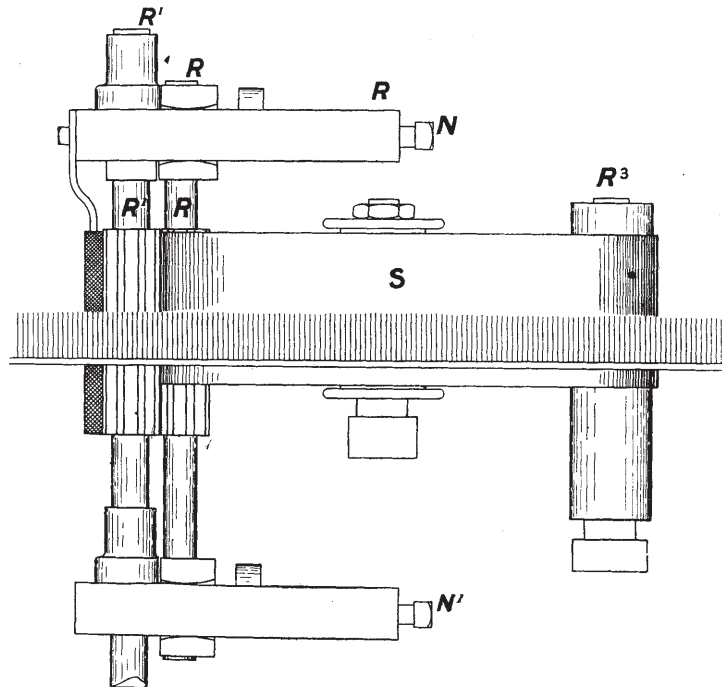

FIG. 103.

circle, causing them to attain a level with the top of the pins in the comb when approaching the position of the dabbing brushes; and, as the surface plate over which the material glides, after being lifted out of the combs by the knives, κ^1 , Fig. 102, is fixed just in front of the dabbing brushes, the respective movements of the circle draws the slivers of the bobbins, D, in the creel, c, Fig. 98, into the machine. The feed boxes on passing the point of contact of the two circles, E, Fig. 101, drop with the delivering end below the top of the pins of the comb, causing the

fibres to be well embedded in the teeth during the removing of the combings from the large circle by the drawing-off rollers.

The four combings—two from the *large circle* at points R and R¹ (Fig. 99); and two from the *small circle* at points R² and R³, are combined and pass through the tube to the can coiler or delivery section of the machine.

72. *Noil Production*.—Having followed the combing and the delivery of the “top,” the method of removing the “noil” may be examined. This is collected in the small circles—the clearing of the material from the large comb each time it revolves, preventing any accumulation of uncombed neppy fibre in the pins—and consists of the material escaping the action of rollers, R², R³, Fig. 98, Plate XXXI. As the circles pass these rollers all the short, curly, rolled filaments are lifted out of the pins by the steel blades set between the circular rows of pins, and drop into a can for the purpose.

The relative percentage of “top” to “noil” is an important factor. In Botany wool combing the averages are higher than in cross-bred wool combing, in which the noil may not be more than 7½ per cent. It is regulated by the setting of the drawing-off rollers. Too keen or close setting, which removes a maximum quantity of top to noil, may be detrimental to the production of a clean, bright top, for when the adjustment is too fine the rollers are apt to clear a percentage of imperfectly combed wool from the pins. The closeness of the setting of the rollers to the combs is therefore determined in relation to the class of wool treated, its condition after gilling, and the quality of top required.

73. *Nip and Square Motion Combs*.—These are two standard machines. The “nip” is the more suitable comb for long or lustre wools, but the square motion comb, like the Noble and rectilinear machines, is used for fine Botany wools. Each machine may be briefly described. Commencing with the “nip” comb—so-called on account of the employment of two metal plates or jaws which close together or nip the material when drawing it from the

PLATE XXXII

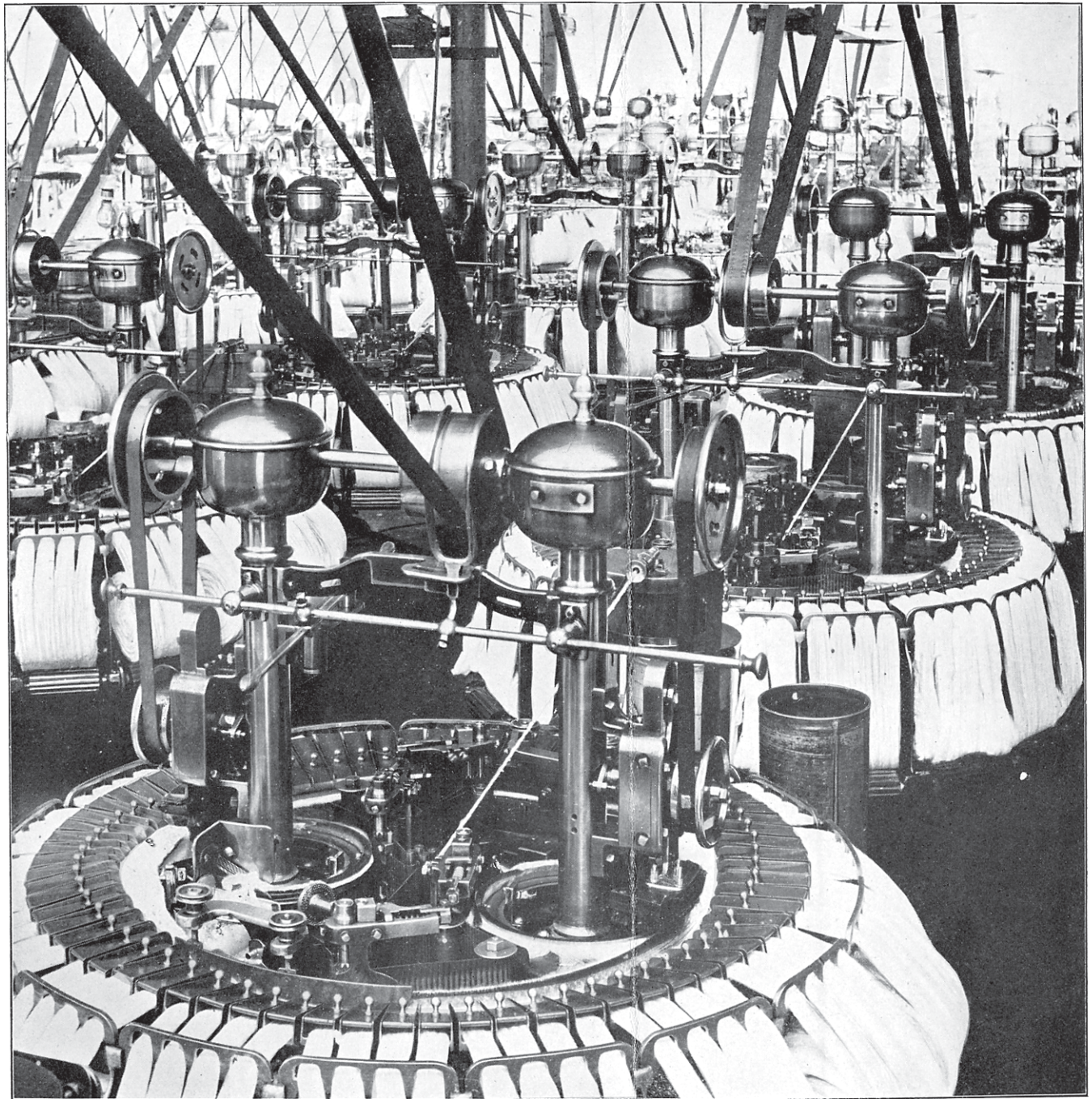

FACTORY VIEW OF NOBLE'S COMBING MACHINES.

[Messrs. Taylor Wordsworth and Co., Ltd.]

fallers—it consists of two distinct sections or parts; first, an ordinary screw gill-box to which is attached the nip mechanism; and, second, the circular comb. The front part of the machine resembles in its main features the gill-box already treated of. In this case, however, the wool is pressed between the teeth of the fallers by the action of a dabbing brush. On the material clearing the last faller it is taken up by the nip, which forcibly draws it through the gill-pins, stretching and combing the fibres in the operation. The wool is now delivered to the carrier comb, which passes it on to the main circle, a second dabbing brush coming into operation. Drawing-off rollers gather the combed fibres off this comb and convey it to the delivery part of the machine. The wool in this routine is submitted to four separate combings: First, between the fallers and the nip; second, between the nip and the carrier comb; third, between the carrier and the main comb; and, fourth, between the latter and the drawing-off rollers. The noil fibre remaining in the comb after passing the drawing-off rollers is cleared by steel knives fixed as in the Noble's machine.

In the *Holden* or *Square Motion* machine the material is carried to the comb by a pair of feed rollers which oscillate backwards and forwards. In the forward position the rollers distribute a portion of the wool on the comb and then recede, drawing or combing out the fibres. The wool remaining on the inner side of the comb constitutes the noil. As the feed rollers keep up a constant supply of wool to the comb, part of the fibres hang loosely from the pins over the outer edge of the circle. In this condition they are carried forward to the square motion, consisting of a set of arc-shaped fallers to coincide with the convex form of the comb. Each of the fallers, as it rises, carries off a portion of the fibrous fringe collected on the edge of the comb. Any noil retained in the fallers, after the combings have been removed by the drawing-off rollers, is extracted by the action of a small comb which is inserted between the gill-pins as the fallers are lowered.

The points at which combing is effected on this principle are: (a) between the feed rollers and the main comb; (b) between the main comb and the fallers; and (c) between the latter and the stripping rollers.

74. *Continental Worsted Comb*.—As stated in Paragraph 71 this comb is of the Heilman or rectilinear type. It has a combing surface of $12\frac{1}{2}$ " in width, with a productive power varying from $13\frac{1}{2}$ to $29\frac{1}{2}$ lb. per hour according to the quality of wool treated. The machine, including the creel (when used), occupies a floor space of approximately $5' \times 10'$, has a speed equal to 95 to 100 "combing" per minute, or 265 to 275 revolutions of the driving pulley, and requires $\frac{1}{2}$ H.P. for driving. From the engraving—Fig. 104—which is a general view of the comb with the slivers drawn from cans instead of bobbins in a vertical creel, it will be noticed this type of machine is compact and neat in construction and design, the working parts being grouped in a manner to secure economy of mechanism and efficiency of running.

75. *Main Features of Rectilinear Comb*.—The main features of the comb are shown in Figs. 105, 107, and 110, and comprise:

- (1) The feed rollers, s s', rotating intermittently, Fig. 107.
- (2) The feed gills, d, Figs. 105 and 107.
- (3) The upper or vertical comb, w, Fig. 107.
- (4) The circular or revolving comb, b, Figs. 105 and 110.
- (5) The nippers, c, for gripping the sliver, Figs. 105 and 107.
- (6) The drawing-off rollers, g, g', Fig. 107.
- (7) The noiling and clearing mechanism, Fig. 110.

Other parts and motions of the machine are sketched in Figs. 106, 108, and 109. Thus Fig. 108 is a section of the revolving comb showing the nipper, c, with brush attachment, and also the dabbing blade, s, on lever L, and its setting in relation to the pins of the comb; Fig. 106 gives the correct line of the material from the feed gills,

D, to the rollers, G, G¹; and Fig. 109 is the toothed segment for turning the drawing-off rollers, and for the recoil (*recoil*) or backward movement immediately after placing on the delivery table of the machine the portion of combed fibres last removed by the rollers from the pins of comb, w, Fig. 107. The length of sliver, carried off

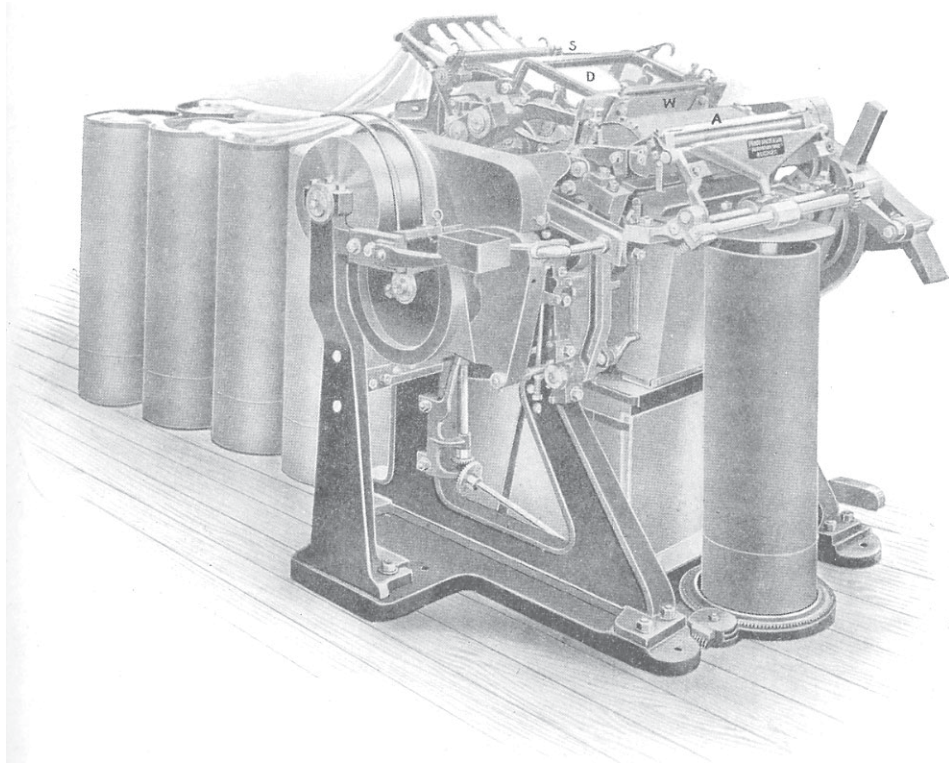

FIG. 104. Rectilinear or Continental Comb (Messrs. Prince Smith and Son, Keighley).

by the rollers at each nip, is determined by the position of the stud, q, in the slot, Fig. 109. If placed in the hole, 5, it would obviously impart the greatest movement to the rack gear, and therefore to roller, G, the pinion of which meshes with this rack; but if the stud is fixed at position 1 the least traverse would be effected to the rollers. Therefore for medium wools, q is fixed at points 5 and 4,

for short wools at points 1 and 2, and for ordinary classes of wools at point 3.

The "recoil" or return action is obtained by the toothed section, A, A¹, of the rack. To diminish or increase the traverse of the "recoil" it is only necessary to re-set, A¹ in the groove, A¹¹; observing in so doing the pinion G gears correctly in the segment rack during drawing off or when the catch is operated.

76. *Principle of Action.*—The principle of the machine is to effect successive combings of the material rectilinearly or in a straight line, namely, the direction in which the slivers pass from the feed to the delivery end of the comb. In this it differs from the Holden, the Noble, and other machines.

The operations are done (*a*), by partial combing when the material is drawn between the gill-pins; (*b*), by the pins of the revolving comb, B, Figs. 105 and 110, which straighten the fibres between the gills and the upper comb; and (*c*) by drawing the fibres projecting from the pins of the fixed or vertical comb by rollers, G, G^t, Fig. 107.

The work of starting the machine in the first instance is done by hand and is accomplished as follows: The "drawing-off" rollers are set in a position for removing a length of the combed fibres when the machine is turned over; and the "nippers," C, Fig. 105, are opened. The vertical comb is raised to render it inoperative; and the dabbing motion is also put out of gear. A clear passage for drawing the slivers through the machine with a minimum amount of resistance is thus prepared. The slivers are taken by hand from the bobbins or cans over the feed-plate, seeing that there is no crossing of the material, and passed slightly beyond the opened nippers. The machine is now turned over until the drawing-off rollers possess an even grip of the fibres. This done, the comb is ready for starting, but it is not the practice to set the dabbers in operation until some short length of treated material has passed through the machine. The object of this is to reduce as much as possible the resistance of the slivers to the action of the

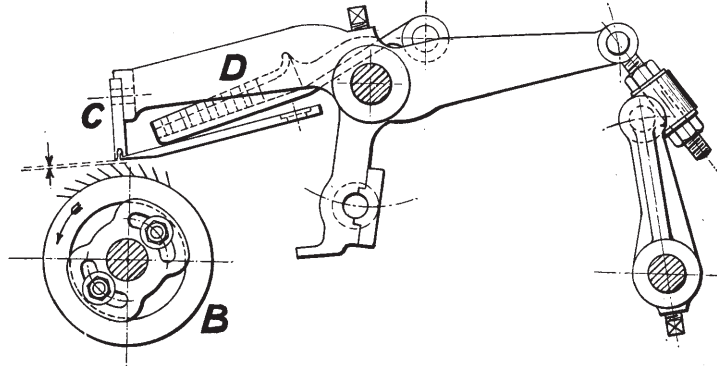

FIG. 105. Section, Rectilinear Comb.
 B=Circular Comb. c=Nipper Jaw. D=Gills.

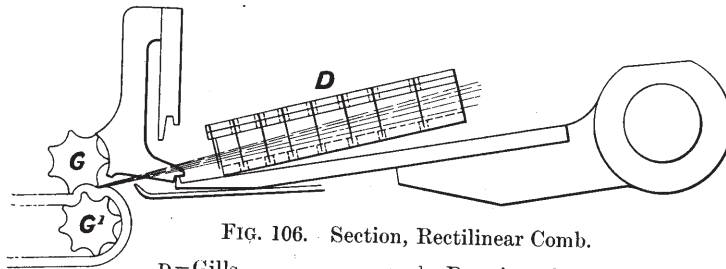

FIG. 106. Section, Rectilinear Comb.
 D=Gills. G G'=Drawing-off Rollers.

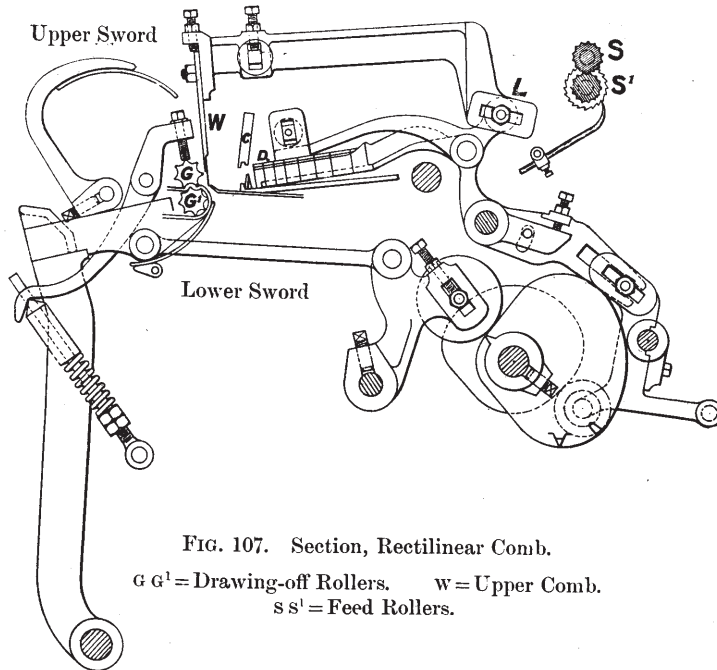

FIG. 107. Section, Rectilinear Comb.
 G G'=Drawing-off Rollers. W=Upper Comb.
 S S'=Feed Rollers.

drawing-off rollers by not pressing the fibres between the pins of the circular comb. Leaving the feeding rollers, the slivers are controlled by the traversing gills, *D* (Figs. 105, 106, 107), to form an even web of fibres for actual combing. The rollers, *s s'* (Fig. 107) feed the material as required, by wheel and catch gearing, *G*, Fig. 109. It follows that at each operation of the drawing-off rollers the combed material is detached, the beard of the fibres projecting in

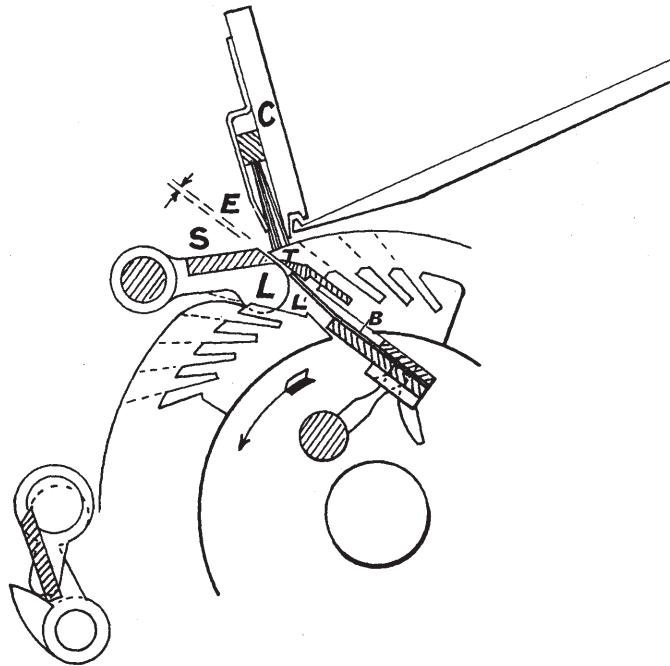

FIG. 108. Section, Rectilinear Comb.

front of the pins of the comb constituting the combed sliver, this being drawn or removed from the pins by *G*, *G'*, in tufts of fibres, and these require to be collected or made into a continuous ribbon or top of the same consistency throughout: that is to say, the ends of the sliver carried off by the rollers and conveyed to the delivery table must be joined—without any appreciable inequality of result—to the ends of the lengths of fibres previously abstracted from the pins of the comb, *w*, and formed into a sliver by passing through an ordinary can coiler device (Fig. 104).

77. *Action of the Rollers, Nippers, and Upper and Lower Swords.*—From this description and also from the nature of the routine of the process, it will be seen that the nippers must be open when the drawing-off takes place, but at the same time the carriage must be stationary. The function of the drawing-off rollers, as explained, is to take off the “beard” of combed fibres projecting in front of the pins of the vertical comb.

During drawing-off, the upper roller, *G*, should lightly

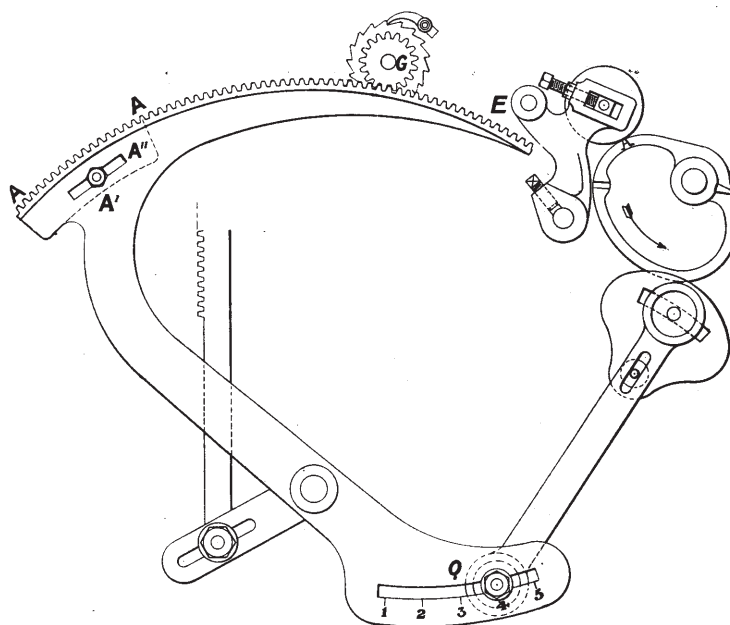

FIG. 109. Section, Rectilinear Comb.

touch the metal part of the comb, but not the pins. The adjustment screw *L*, Fig. 107, is used for setting this comb in relation to rollers, *G G'*. To set the rollers parallel with the nipper they are adjusted by altering the position of stud *A*¹ in the slot *A*¹¹, Fig. 109.

The efficiency of the work of the nippers is affected by the setting of the bar, under the lower jaw, Fig. 107. The object of this bar is to control the fringe of fibres projecting from the nippers. For satisfactory production the point of the lower bar should be set close to the pins

of w , or within $\frac{1}{32}$ " or at the extreme $\frac{5}{64}$ ". Setting nuts are used for varying the distance of the bar from the pins of comb, w .

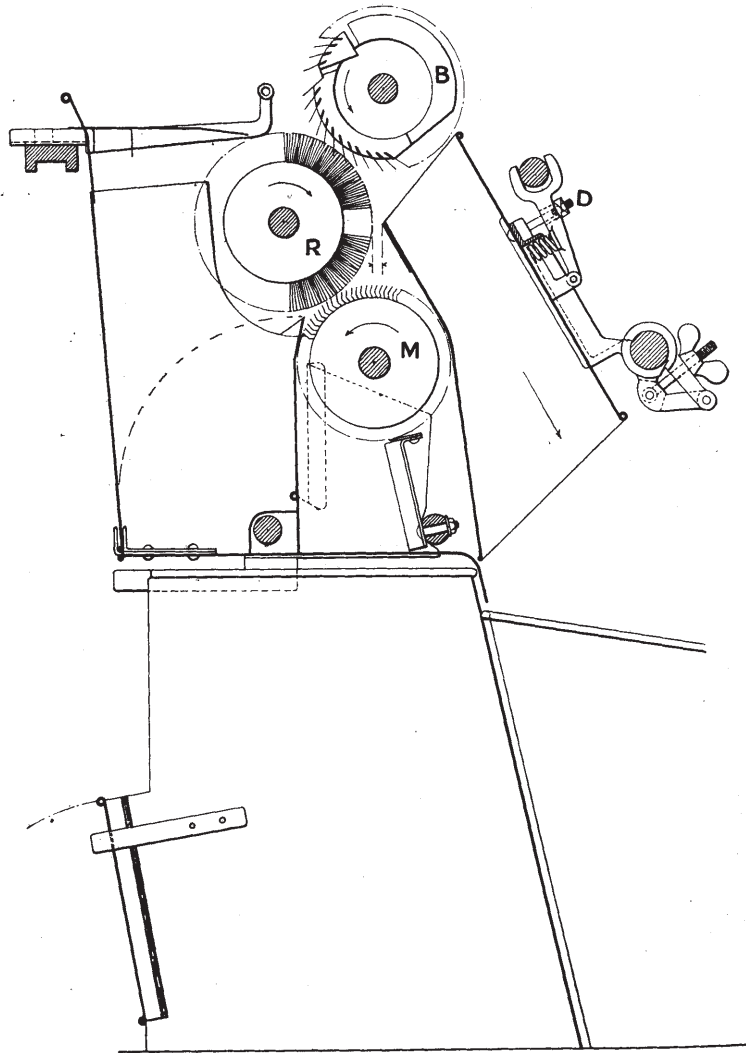

FIG. 110. Section, Rectilinear Comb.

To facilitate drawing-off in the treatment of medium stapled wools, the upper and lower swords, Fig. 107, are employed for controlling the long fibres. Thus the former presses such fibres against the bearing surface of the lower sword, the material being drawn through the vertical comb,

w. In combing short-fibred materials these parts are not necessarily used; but for those of a moderate length they supplement and assist the action of the rollers, which are insufficient to draw off all the long fibres until the upper sword has operated on the wool being treated.

The point of this sword is set almost in contact with the pins of the comb, and operates immediately following the withdrawal of the rollers, $G G^1$, thus at once attaining a working position. If this were not done, the liberated fibres would not be satisfactorily carried forward by the draw rollers. When the upper sword is in action there should be approximately a space of $\frac{5}{32}$ " between it and the point of the bottom sword.

The setting and working of the dabbling motion (Fig. 108) are important to efficient running and good combing. In the sectional drawing, the dabbling blade is in the bottom position, or when it has pressed the fibres of the wool between the pins. Part s of the dabber is set as close as possible to the nippers, c , so that it just touches the brush, E , in its descending movement. The jaw is also fixed to work about $\frac{1}{32}$ " from the pins of the comb fallers. Projection L^1 of the comb engaging projection L of the dabber carries the dabber forward for $\frac{1}{32}$ " whilst in the working position. Then, by eccentric control, a greater speed is given to the dabber than to the comb disengaging projections L and L^1 , and lifting the blade, s , out of the pins.

78. *Noiling and Burring*.—The mechanism for this work is sketched in Fig. 110, but the noil and other vegetable matter are removed from the pins of the fallers of the circular comb each time it revolves by the "unburring" blade, T , Fig. 108 (fixed in the interior of the comb), which operates in conjunction with the dabber. This blade is automatically pushed forward to the extremity of the pins—but not beyond—and drawn backward to raise impurities from the bottom of the pins ready for removal by the brush, R , Fig. 110. The heavier impurities are thrown into a can placed underneath the working parts of the comb; whilst

the noils taken from the brush by the doffer, M, are combed off by a doffing comb and pass into a compartment at the front of the machine. Suitable means of adjustment are provided to counteract the effect of wear on the brush roller.

The Tables on pages 219, 220, and 221 are printed from the *brochure, Réglage et Renseignements concernant la Peigneuse-Laine*, published by the "Société Alsacienne de Constructions Mécaniques."

79. *Carded and Combed Wools*.—The combed top (Specimen 2, Plates XXIV and XXV), which form the basis of the worsted thread, consists of quite a different arrangement of fibres from the sheet of carded wool (Specimen 7). Fibres in the "top" are comparatively straight, curliness having been combed out of the staple of the wool in addition to the neppy and clustered fibres having been removed. In the carded material the fibres retain much of their natural curly character, and have no resemblance to uniform parallel relation. The top is, moreover, composed of selected fibres, whereas the carded sliver is composed of every variety of fibre in the raw material; but in one essential particular carded and combed wools have corresponding qualities—the fibres in each condition are so grouped and arranged as to be suitable for being made into a yarn by the process of spinning.

The dissimilarity in the effects of the worsted and woollen methods of yarn construction are also distinguishable in the final stages of preparation as in the carded and combed materials. Note, for example, the difference in the structure and characteristics of the rovings and the condensed slivers (Specimens 4 and 8, Plates XXIV and XXV). How comparatively level and even the structure of the former as compared with the latter; the sliver is irregular in diameter, the fibres hang loosely together, and lack the qualities of adhesiveness and compactness seen in the roving. The relative diameters of the roving and the spun yarn, and of the sliver and the spun yarn show that the roving requires to be more reduced

TABLE VI
METHODS OF SETTING AND DATA FOR USING THE RECTILINEAR COMB ON VARIOUS CLASSES OF WOOLS

Sorts or Classes of Wool.	Setting between Drawing-off rollers and Nippers.	Feed Mechanism.		Slivers or Materials.		Top Comb.			Position of the lever for drafting, Q, Fig. 109.	Finishing (Half-lap) Segment to employ.
		Number of teeth in Ratchet Wheel.	Length of Sliver Feed.	Weight per Metre each Sliver.	Weight per Metre of 24 Slivers run as one.	Number of pins per centimetre.	Number of round pins.	Projecting points of the Pins.		
A. Long, coarse, open-fibred wools	mm. $\left. \begin{array}{l} 23 \\ \text{to} \\ 26 \end{array} \right\}$	13	mm. 9.5	gr. 12	gr. 288	22	$27\frac{11}{16}$	mm. 8	No. 1 or 2	IV
B. Crossbred wools, such as Buenos Ayres or Australian	$\left. \begin{array}{l} 20 \\ \text{to} \\ 22 \end{array} \right\}$	15	8.2	10 to 12	240 to 288	22	$27\frac{11}{16}$	8	No. 3	II
C. Fine neppy wools	$\left. \begin{array}{l} 23 \\ \text{to} \\ 24 \end{array} \right\}$	17 to 19	7.2 to 6.5	7.6 to 9.8	182 to 235	23	$27\frac{11}{16}$	8	No. 3 or 4	III
D. Very fine Burry wools (Australian) containing burrs and vegetable impurities	$\left. \begin{array}{l} 23 \\ \text{to} \\ 24 \end{array} \right\}$	19	6.5	7.6 to 8.6	182 to 206	23 or 25	$27\frac{11}{16}$ or $28\frac{11}{16}$	8	No. 3 or 4	III
E. Short wools, such as Lambs'	$\left. \begin{array}{l} 20 \\ \text{to} \\ 21 \end{array} \right\}$	19	6.5	7.6	182	23	$27\frac{11}{16}$	8	No. 5	III or II

TABLE VII

PARTICULARS OF THE FALLERS (*BARRETTES*) OF AN 18-SET CIRCULAR
COMB IN A RECTILINEAR COMBING MACHINE.

SEGMENT I

First Opening Section of the Comb employed for all Classes of Wools.

No.	Number of pins per centimetre.	Number of round pins.	Projecting points of the Needles.	Depth of the needle-bars.
1	4	19 $\frac{1}{2}$	7 mm.	21 mm.
2	5	"	"	"
3	6	"	"	"
4	8	21 $\frac{1}{2}$	"	"
5	10	22 $\frac{1}{2}$	"	"
6	12	24 $\frac{1}{2}$	6 mm.	22 mm.
7	12	"	"	"
8	14	"	"	"
9	14	"	"	"

SEGMENT II. (Finisher)

For Crossbred and similar Wools.

10	16	26 $\frac{7}{16}$	5 mm.	23 mm.
11	16	"	"	"
12	19	27 $\frac{7}{16}$	"	"
13	19	"	"	"
14	22	"	4 mm.	24 mm.
15	26	28 $\frac{7}{16}$	"	25,7 mm.
16	26	"	"	"
17	26	"	"	"
18	26	"	"	"

SEGMENT III. (Finisher)

For fine, neppy, and burry Wools.

10	16	26 $\frac{7}{16}$	5 mm.	23 mm.
11	19	27 $\frac{7}{16}$	"	"
12	22	"	4 mm.	24 mm.
13	26	28 $\frac{7}{16}$	"	"
14	28	29 $\frac{7}{16}$	"	"
15	28	"	"	25,7 mm.
16	28	"	"	"
17	30	30 $\frac{7}{16}$	"	"
18	30	"	"	"

SEGMENT IV. (Finisher)

For long and Coarse-fibred Wools.

No.	Number of pins per centimetre.	Number of round pins.	Projecting points of the Needles.	Depth of the needle-bars.
10	16	26 $\frac{7}{16}$	5 mm.	23 mm.
11	16	"	"	"
12	16	"	"	"
13	19	27 $\frac{7}{16}$	4 mm.	24 mm.
14	19	"	"	"
15	19	"	"	25,7 mm.
16	22	"	"	"
17	22	"	"	"
18	22	"	"	"

or drafted in the spinning operation than the woollen sliver.

80. *Process of Drawing (English System).*—The principle of the drawing operation is that of combining several slivers and drafting them to such a degree as to produce a thick, soft thread which, when twisted, will form a yarn capable of bearing the tension and friction of the weaving routine. Two or more slivers are successively united and drawn to a length equal to the sum of their combined lengths, that is to say, if six ribbons were put together and elongated into one, a yard of the combined sliver would be attenuated to the length of the six and reduced to a size corresponding to one of the six. This system of equalizing and levelling the slivers rectifies any unevenness and further adjusts and straightens the fibres. Six or nine machines are employed, all built on a similar principle. Each machine has two pairs of rollers, revolving at different speeds, one pair receiving the slivers, and the other delivering them. Draft or attenuation is, in every machine, effected on this system. The “ratch” or draft is varied according to the average length of the fibres of the wool, a reduction being made as the material passes from one frame to another, the increase in length of the sliver in each box being in the same ratio as the speeds of the two pairs of rollers to each other.

When six machines are employed, the doublings may be as follows: Six slivers at the first and second frames, five at the third, four at the fourth and fifth, and two at the rover. Should the set contain nine machines, as is the case for fine wools, then the roving produced would result from some 288,000 doublings. The order of doubling in such a series of machines would be eight at the first frame; six at the second; five at the third, fourth and fifth frames; four at the sixth; three at the seventh; two at the eighth; and two again at the roving frame. In this routine, the slivers are attenuated from each end alternately in order to distribute the direction of the drawing tension put on the fibres as much as possible, and also to prevent the formation of an uneven ribbon.

81. *Drawing Machines (open and cone construction).*— There are two distinct classes of drawing frames, namely, English and French. The former are divided into *open* and *cone* drawing. In the English frames, the arrangement of the rollers for drawing is similar to that in the gill-box, but for wools that have only been carded and not combed or gilled, fallers are not used in any of the boxes. As the short fibre remains in the material when prepared by this method of worsted yarn making, to pass the wool between a number of gill pins in drawing would impair the regularity of the sliver, for as each faller dropped out of the material it would leave short filaments lying across the sliver. The slivers from the first and second boxes are delivered into cans (in Fig. 111, the balls in the creel from the finisher gill-box are drafted to the size of one sliver, and two slivers or slubbings from the six balls in the creel are delivered into the cans), but in the subsequent frames some slight twist is given, so the material is wound on to bobbins, the size of the latter, as well as of the slubbing, decreasing as the material passes from frame to frame.

For System II of worsted thread construction (paragraph 64), the first two or three machines are mounted with fallers like the gill-box, the remaining frames in the