

## PART III.

### HARNESS MOUNTING.

---

#### CHAPTER XVII.

##### Principles and Routine of Harness Mounting.

HARNESS mounting, which is very frequently designated the 'tie-up' of the harness, is the generic term used to express the arrangement, order and number of harness twines which are connected to each neck band, tug cord or hook, and their distribution in the comberboard. It is not necessarily a part of the Jacquard machine; on the contrary the Jacquard apparatus is an invention designed to select and operate the harness twines which in earlier days were acted upon by the draw loom.

##### **Sequence of Processes in Harness Building.**

Harness building embraces a series of operations, involving the preparing and making of the mail couplings, cutting and tying the tug cords to hooks, warping the harness twines, tying the harness twines to the tugs, threading the harness twines through the perforations in the comberboard after the latter has been marked off according to pattern, hanging the couplings on to the harness twines and then levelling the harness. Varnishing is an auxiliary operation.

**Variety of Knots in Harness Tying.** A complete connection from the uprights to the lingoes with all the different kinds of *nautical* knots which have to be used in the processes of harness building is shown at Figs. 269 to 272 inclusive.

Fig. 269 shows one complete series of knots in the cords for tying *below* the comberboard.

Fig. 270 shows the same details and their relative positions when tying *above* the comberboard.

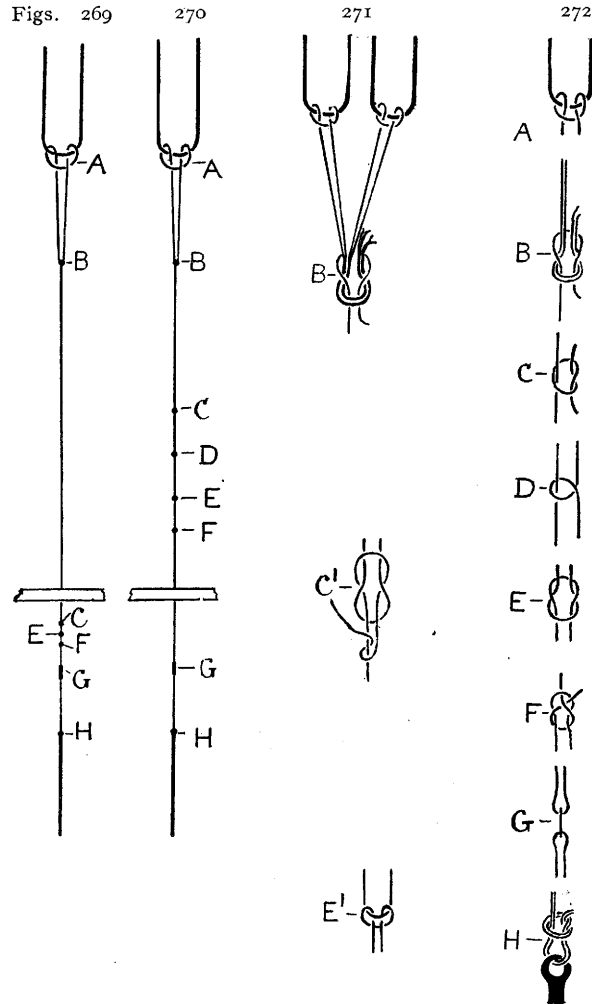


Fig. 271 shows the connection of the harness twine with two uprights of a double acting Jacquard.

Fig. 272 shows all the foregoing knots in detached and enlarged form so that they may be more readily and thoroughly understood.

A is the tug knot; B the top harness knot; C a sailor's knot. Sometimes the loose end of the twine for the knot C is hitched back as shown at C<sup>1</sup> and especially is this plan adopted when only one harness cord is tied up to each hook; *e.g.*, in twilling machines the twines are usually knotted direct to the hooks, the life of the harness being, as a rule, more than sufficient to outlast the style of pattern. D is a 'hitch' knot; E and E<sup>1</sup> flat knots, in two forms for connecting the upper coupling with the harness twine; in their initial stages both knots are formed alike. The form E<sup>1</sup> is the firmer and cannot slip whether varnished or not; the loop is sometimes left as at E which after varnishing does not slip. If it is necessary subsequently to untie this knot, as is frequently the case when the width of the border or harness has to be changed, the bottom *loop* can be easily turned back, which facilitates the loosening. F is a weaver's knot in the top coupling. G is simply threaded through the mail. H is the regular sailor's knot and connects the bottom coupling with the lingoe. From the hook to the lingoe there are four distinct lengths of cord, viz.:—(1) The tug or neck between A and B; (2) the harness twine from B to E and back to C; (3) the upper coupling between F and G connecting the harness with the mail and (4) the lower coupling from G and H which connects the mail with the lingoe weights.

Tying below the board is almost universal in the North of Ireland where an enormous amount of Jacquard weaving is practised. The chief advantage claimed for this method is the increased facility for levelling the harness since each cord hangs in the same vertical and normal position below the board, and each knot is tied under the same conditions and strain or pull on the harness twine. When tying above the board, especially for border patterns, the strain or pull on the harness at both sides of the loom is different, in addition to which there is a constantly varying pull from the inside to the outside of each border, due to the various angles from the hook to the comberboard, all of which increase the difficulty of tying and levelling the harness. When tying below the board, the harness twines pass singly through it, but when tying above, they are threaded doubly through the perforations.

**Tying below  
and above the  
Board—  
a comparison.**

The height of the board above the mails must be greater in the former case than in the latter, which is a certain disadvantage, since the further the board is from the mails, the greater is the tendency of the lingoes to swing to and fro with the mails and warp.

**Making the  
Upper and  
Lower  
Couplings.**

The upper couplings connect the mails to the harness and the lower couplings link the mails with the lingoes. Both the upper and lower couplings are made of cotton; they have to be reeled and cut *double* length. The usual reeled length of the upper is  $12\frac{3}{8}$ " and that of the lower  $16\frac{1}{2}$ " which when doubled and knotted, yield 6" and 8" respectively, being sufficient in length to permit the formation of the warp shed without any interference from the knots F and H (Fig. 269).

Fig. 273 is a front elevation of the adjustable reel as used for winding the required lengths of coupling cords.

Fig. 274 is a side elevation of the same reel, the wings or arms A of which are free to be shortened or drawn out to suit the required circumference of reel and length of cotton cord. The central shaft B is supported by and free to rotate between the fixed uprights C and C'. The mechanism is simple and therefore requires no detailed explanation.

After reeling and cutting, the upper couplings are threaded through the mails, then knotted and slipped on to the arm of the operative until a convenient number has been made. They are then placed on a straight round iron bar C as in Fig. 275, where A represents, in elevation, a portion of an ordinary table.

B and B<sup>1</sup> are two upright iron standards fixed to the table top; C rests freely in the grooved tops of the standards B and B<sup>1</sup>. An end elevation of these details is supplied at Fig. 276. The mails D with the upper couplings E are next slipped from the operative's arm on to the rod C, two such couplings being shown in the position E<sup>1</sup>. The next operation is to thread the lower coupling F through the mail D as shown in the position G. The coupling cord F is then doubled and fastened by a reef or sailor's knot to the lingoe H as shown in the position I. As the couplings are completed they are

placed alternately in front and behind the cord J, so as to form a half lease and avoid any entanglement.

**Tugging Operation.**

The next process in order of sequence is 'tugging' which consists of first reeling the cords to the required approximate length as for couplings, and then fastening them by reef knots to the bottom of the Jacquard hook, after the manner shown at A, Fig. 272.

Fig. 273      Fig. 274

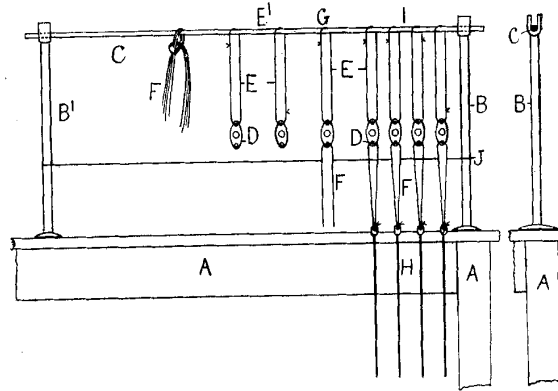
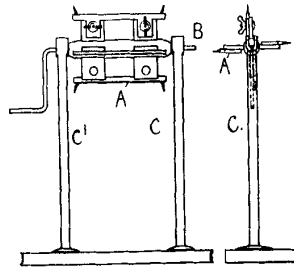


Fig. 275

Fig. 276

**Warping the Harness Twines.**

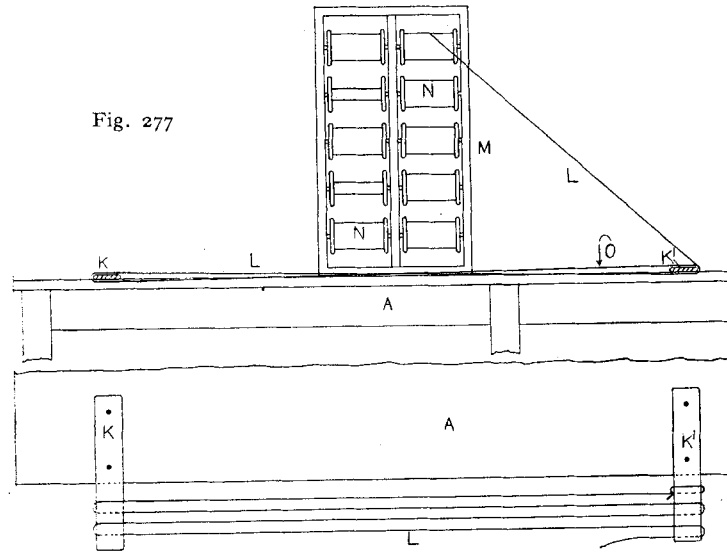
This process is simple and is frequently performed as follows:—Figs. 277 and 278 show respectively an elevation and a plan of the chief details which facilitate the operation. A is an extension of the table shown at Fig. 275. κ and κ' are smooth and flat pieces of

hard wood fastened to the table *A*, but a slot in the table admits of a free and extended or contracted distance between  $\kappa$  and  $\kappa^1$  to suit the length of twine *L* required. *M* is a warper's small bank constructed to hold ten spools or bobbins *N*.

The harness twine *L* may be taken from one or more spools *N* to suit the number of twines which have to be attached to each tug cord. When only one harness twine is required to be attached to each tug cord the warper might use one or any odd number of threads and warp in the usual manner until the full complement of twines have been warped. A lease cord is then passed through the divisions formed by the rods  $\kappa$  and  $\kappa^1$ . The twines *L* are afterwards cut at both ends  $\kappa$  and  $\kappa^1$ , but a cord is previously tied round one or both to prevent subsequent 'tossing.' When two harness twines are required for each tug, the warped twine is only cut at the end  $\kappa^1$ . If, owing to the different angles they have to form in the subsequent mounting, one twine must be longer than another, *e.g.*, in a cross border, on a wide loom, then the cords are cut in one or other position near  $\kappa^1$  as indicated by the arrows *o*. When there are four, six, eight or any even number of twines to be tied to each tug cord, it is generally most convenient to warp with two, three, four or half the number of twines required for each tug. The lease is then formed in twos, threes, fours or other number used for warping; the lease cord is next put in between the pegs  $\kappa$  and  $\kappa^1$ , and the twines are cut and tied at  $\kappa^1$ . The groups of four, six, eight or other double number of twines warped can be readily drawn from each completed bunch of harness twines and knotted on to the tugs. If nine twines are wanted to each tug cord, then two bunches are warped, one containing double fours, and one single twines. The harness mouter then extracts eight of the double fours and one of the single, and knots the same to the tug cord. The single twine is sometimes doubled back a few inches to form a loop before tying it to the tug, see *c*<sup>1</sup> Fig. 272, in which case these particular twines must be warped two or three inches longer than the double fours which have a natural loop. This arrangement prevents the single cord from slipping out of the tug knot.

When there are several twines connected to the same tug cord, they are usually interlaced by a fine cord, a few inches below the tugs to form a flat surface and keep them in their normal position.

When all the harness twines have been knotted to the tugs, they are threaded through the comberboard, after which the lingoes are 'hung' on to them. These, together with the couplings are first loosely tied to the harness, and then allowed to remain for a



few days, so as to stretch the twines and accustom them to the surrounding atmospheric conditions, before proceeding with the levelling operation.

**Levelling the Harness Below the Board.**

Fig. 279 shows in elevation, and 280 a plan of the arrangement for levelling the harness, when tying has to be performed below the board. The mails, upper and lower couplings and lingoes are indicated at D E F G respectively. N is a rectangular frame made of either wood or iron, and perforated as at o. The inside dimensions of this frame are slightly in excess of the width and length occupied

by the lingoës suspended from the harness. It is supported by two adjustable angle bars  $P$  and  $P^1$  to the loom gable  $Q$ . Both bars are slotted and adjustable as shown, at the overlapping part as well as at the positions connected with the frame  $N$  and the loom gable  $Q$ . The comber board is shown at  $R$ , and the harness cords attached to the couplings, before levelling at  $s$ , and after levelling at  $s^1$ . The frame  $N$  is first adjusted, made perfectly level and then screwed tight between the loom gables  $Q$ . A line, consisting of a strong piece of cord  $T$ , is laid straight across the top of the frame  $N$  and weights  $U$  and  $U^1$  are suspended at either end (see also Fig. 281). One row of couplings is then placed alongside this straight line of cord  $T$ , the temporary knots  $V$  are untied and the harness twine is drawn through the upper coupling  $E$  until the centre of mail  $D$  is perfectly coincident with the line  $T$ ; the harness twine is then knotted after the manner shown at  $F E C$ , Figs. 269 and 272. Each succeeding harness, coupling and mail in every row of harness from front to back is similarly levelled. As each row of harness is completed it is lifted behind one of the movable steel pins  $w$ , which is passed through the perforations in  $N$ . These pins are used simply to keep the levelled harness separate from the unlevelled and thereby leave sufficient room for the harness mouter to work freely with his hands.

**Levelling the  
Harness 'Above  
the Board.'**

Whenever this method is adopted the lower couplings, on one full row of harness, are placed individually over a long narrow levelling board technically called a 'slabstock.'

Fig. 282 is a front elevation of a portion of the slabstock with the upper and lower couplings slipped over it. Fig. 283 is a sectional elevation of the same details.  $D E F G$  are the mails, upper and lower couplings and the lingoës respectively.  $w$  is the slabstock with a groove  $x$  large enough to admit of the mail  $D$ . A steel wire  $y$  is passed through the eyes of mails  $D$  and maintained in the groove  $x$  through the medium of a piece of cord  $z$  tied at regular intervals over the wire  $y$  and slabstock  $w$ . The slabstock is then adjusted to the loom gables as in Fig. 279, and levelled preparatory to tying in the harness. When this operation is complete a young person threads the upper coupling  $E$  through the perforations in the comber



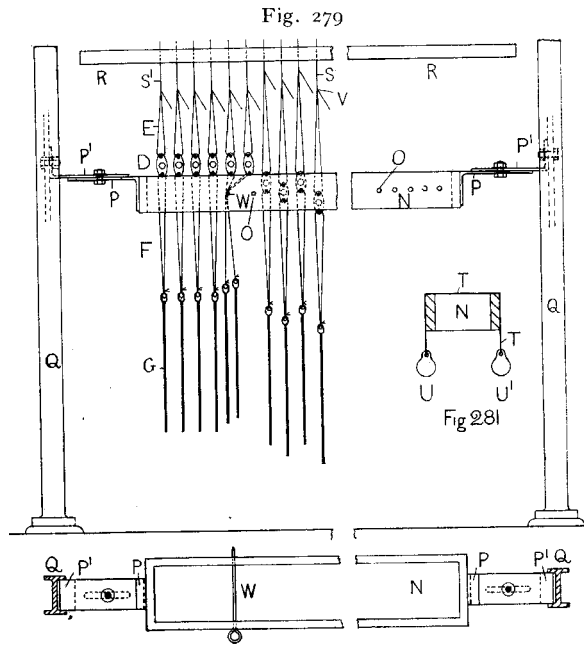
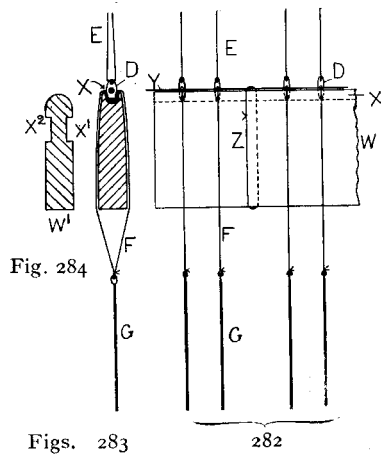


Fig. 280



Figs. 283

282

board after the latter has been marked off to suit the width of the harness. The harness is next passed through the loop of the upper couplings *E*, which together with the harness twines are drawn to their normal tightness and then knotted as at *F E D C*, Figs. 270 and 272. This process is repeated with each separate row of harness until the whole is complete.

In some districts the harness twine is threaded through the mail *D*, there being no upper coupling.

An alternative type of slabstock is sometimes preferred, and this is illustrated at Fig. 284.  $w^1$  is the slabstock with two grooves  $x^1$  and  $x^2$ . By this arrangement two rows of harness can be manipulated at the same time. The harness twines are selected close to the tug cords, in rotation, by an assistant who then passes them down in the same order to the harness tier.



## CHAPTER XVIII.

### Principles and Varieties of Harness Mounting.

It is of primary importance to determine which hook in a Jacquard has to be reckoned as the *first* for purposes of mounting and subsequent card stamping and lacing.

In this treatise the *first hook* and *harness cord* are invariably reckoned from the *left* when viewed from the front of the loom and the spring box; this is equivalent to reckoning from the top hole in the card cylinder and the bottom needle in the needle board on the right hand side when viewed from the back of the loom and facing the card cylinder, see Figs. 285 and 286.

The above method, being most natural will commend itself to most practical minds, *e.g.*, if the point paper or painted design be placed in front of the harness at the loom, then the warp thread on the extreme left will coincide with the harness cord and the front hook on the same side; also the direction and appearance of the reproduced design in the cloth, as it appears in the loom, will exactly agree with that of the painted design. The card cutting will then begin, for the first pick, at the bottom and left hand corner of the point paper design.

In some districts, the converse of this principle is adopted, the first hook being reckoned from the left hand as viewed from the back of the loom. With this arrangement the tying up is reckoned from the right hand side at the front of the loom and the point paper design, for cutting, has to be read from the top right hand corner, which to say the least is somewhat confusing.

#### **Systems of Harness Mounting.**

There are two chief systems in common use, *viz.*; the Norwich and the London, sometimes denominated the French; the former method is however most generally adopted.

**Norwich  
System.**

With this system the Jacquard machine and card cylinder are arranged parallel to each other so that the cards and cylinder operate either at the back of

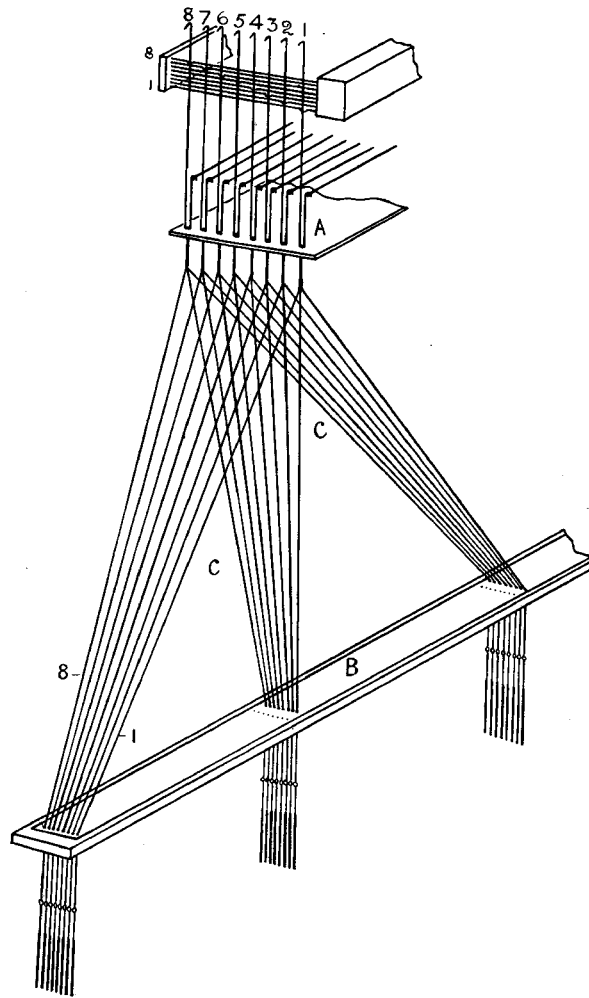


Fig. 285.

the loom, over the warp yarn, or at the front, above the head of the weaver.

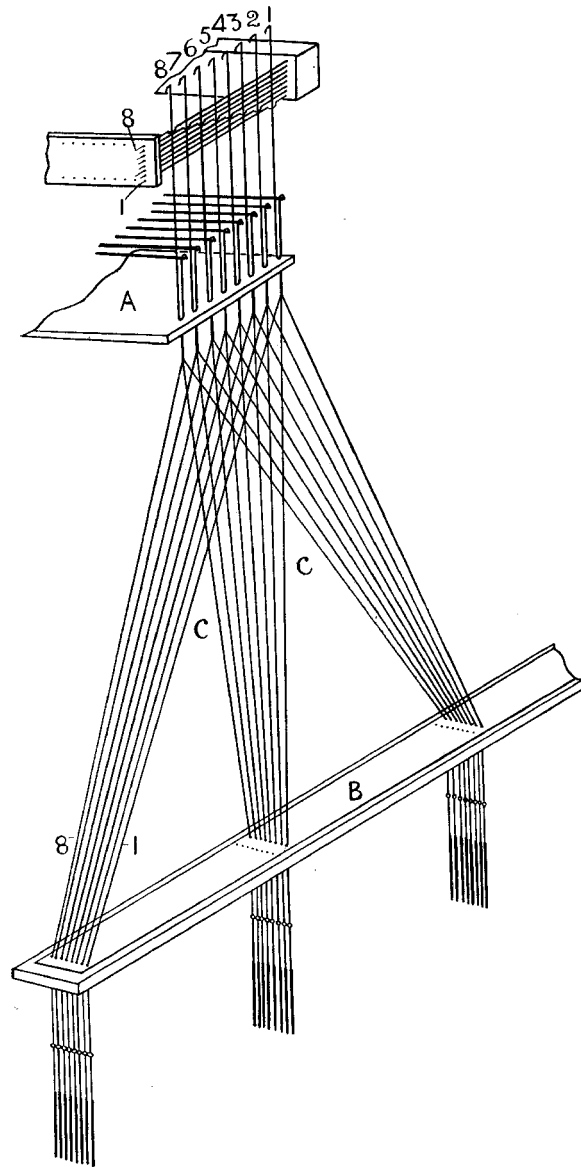


Fig. 286

Fig. 285 is a perspective sketch of this system. The view is from the left front of the loom. A shows the tug board and B the comberboard; three repeats of the harness C are shown tied up to the first hook of each row from front to back. Each row of harness twines is brought straight down and through the comberboard B and the number of such rows usually coincides in depth with the number of rows of uprights from the front to the back of the machine, as in the illustration.

With this system the Jacquard machine and card cylinder are placed at right angles to the comberboard, so as to allow the cylinder and pattern cards to work at one side of the loom. This is a convenient method for the hand loom weaver since he can watch, reach and control the cards as he sits and weaves. The disadvantage of this method is that each row of harness receives a quarter twist in passing from the hooks at the left side of the loom, to and through the comberboard at the front, which generates friction and complicates the mounting. Fig. 286 is a perspective sketch of this method of mounting as seen from the left front of the loom. A and B indicate the top and bottom boards respectively, and C the harness twines for three repeats tied to the first hook of each row.

#### Comberboards and Harness Reeds.

The comberboard may consist of one solid board of box, beech, or other suitable wood, and is perforated to any required fineness, each perforation normally corresponding to one thread of warp in the cloth.

During recent years the solid comberboard has been extensively replaced by the use of small slips which represent transverse sections of the ordinary comberboard. The slips are perforated according to fineness, fixed in a frame and tightened up to correspond to the solid comberboard. The chief advantage of the slips is that they permit a slight adjustment in the width of the harness by the insertion of solid pieces of wood between them.

There are three chief orders of perforations in the comberboard or slips, and these are shown as follows :—

Fig. 287 shows one slip with the perforations in the same order as a "plain weave pattern." This style is the most common; it is economical in respect to the distribution of the perforations and the subsequent distribution of the lingoes.

Fig. 288 shows one slip with the perforations arranged in straight order from front to back.

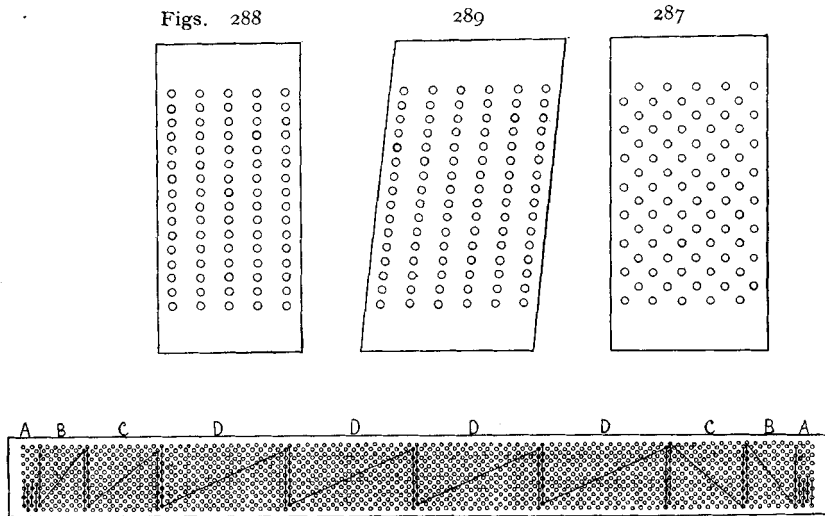


Fig. 290

Fig. 289 is a modification of the order illustrated at 288. It shows one slip in which the perforations are designed to run diagonally from the front to the back of the comberboard, the object being to cause each mail, together with its subsequent warp thread, to lie, without strain, directly in the same plane as the split in the reed and the warp in the cloth.

**Harness Reeds.** Ordinary loom reeds are sometimes used instead of comberboards or slips, one short row of harness being threaded through each split in the reed. Each row of harness is kept distinct by drawing cords tightly across the full length of the reed and between the rows of harness.

The splits per inch in the harness reed are determined by the number of harness cords per inch divided by the number of harness cords which are designed to pass through each dent in the reed.

**Marking off the Comberboard.** The comberboard is usually perforated to correspond with the exact fineness of the required set in the harness; sometimes however, it is slightly finer, in which case the extra rows must be left empty, or it may be that in some sections of the pattern, only part of a row is required.

First mark off the width in the comberboard which the harness must cover—usually a shade wider than the width of the warp in the reed. The centre of the harness and the comberboard should exactly coincide with the centre of the loom.

Next divide the portion of board set off into the required number of sections, to suit the tie up; each section must contain the necessary number of rows and holes for the harness cords allotted to it; then draw diagonal lines from the first to the last hole in each section, in the direction the twill is required to run. These serve as guides to the proper threading of the harness. Lines are only drawn across the holes in the comberboard which require to be filled.

Fig. 290 illustrates the common method of marking off a comberboard to the following given particulars.

	No. of hooks	Cords per hook	Total cords
A Edges	4	$4 \times 2$	16
B Sateen	16	$6 \times 2$	96
C Border	144	$1 \times 2$	288
D Centre	240	4	960
			1360

### Classification of Harness Ties.

Harness mounting may be divided into four chief classes :

1. **The Single Tie.** This tie is only required when there is no repetition of any of the pattern. One harness cord only is tied up to the hook of the Jacquard and there must be as many hooks as there are threads of warp. The cords



are tied to the Jacquard hooks and taken down through the comber-board in regular order from first to last consecutively. The warp threads are successively drawn through the mails of the harness in the same order.

This principle of mounting, though affording unfettered scope, for the designer, to the full capacity of the figuring hooks, is not extensively employed except for carpets and similar fabrics which

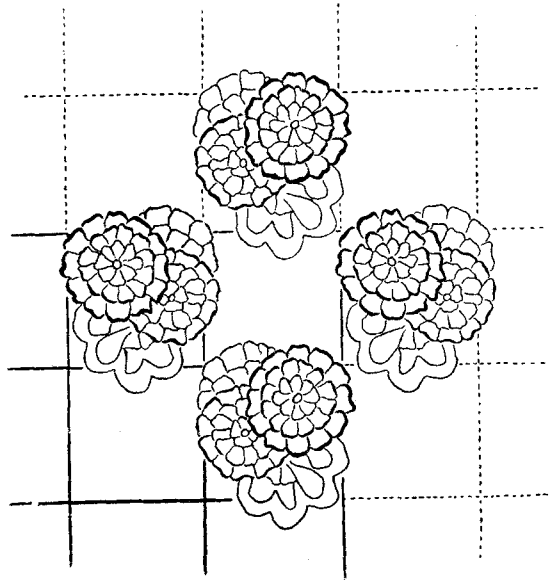


Fig. 291

have subsequently to be stitched together to make greater widths of fabric. Under these circumstances the principle may be employed advantageously to produce an effect of figured pattern which is equal to double the normal figuring capacity of the machine.

Fig. 65, page 69, shows an example of mounting the harness twines to the Jacquard hooks for a single repeat. The frontispiece is an example of a pattern requiring a *single* mounting tie.

**2. The Repeating or 'Lay Over' Tie.**

This is the commonest tie and is used for all figure designs which contain more than one repeat of pattern in the full width of the cloth.

Fig. 51, page 47, shows an example of a repeat-

ing tie with four repeats of pattern across the comberboard and warp. The first row of harness only is shown, each subsequent row being a duplicate of it. Fig. 291 shows two repeats of a simple repeating pattern.

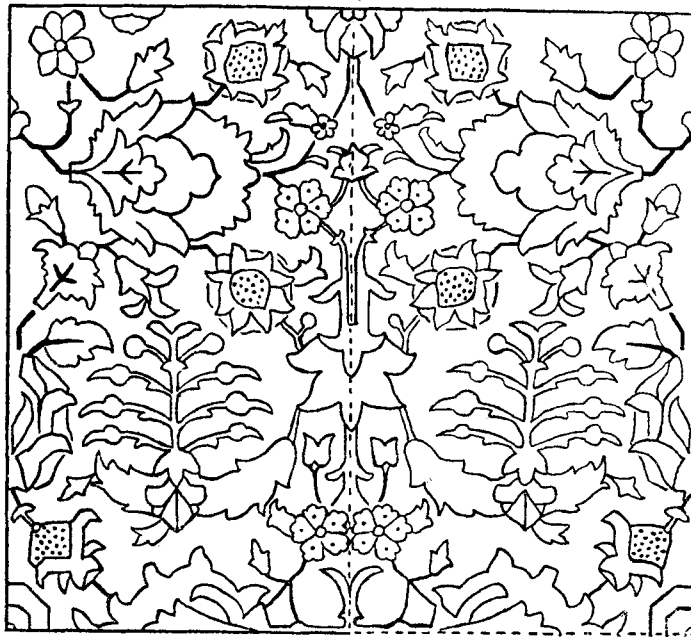


Fig. 292.

**3. The Centre, 'Point' or Turn-over Tie.** This tie is used when the two halves of any figure or border are alike when turned over. In all such cases a repeat of the pattern only requires half the number of hooks to complete it. This principle of mounting is largely used for silk ribbons, curtains, serviettes, tray cloths, upholstery and carpets. Its chief advantage probably consists in its adaptability and extensive use for border and compound effects of pattern. The method usually adopted is to connect the harness twines in regular order from the first to the last hook of the machine and then to pass them successively through

the comberboard. Then, from the last hook but one, the harness twines are selected in the reverse order and again passed through the comberboard, with the result that the pattern is turned over and made double the original size.

The first half of the mounting of Fig. 266, shows an example of tying up the harness twines for a simple turn-over effect of pattern. Fig. 292 shows a simple turn-over pattern.

**4. Complex Ties.** Complex ties are composed of a judicious combination and re-arrangement of two or all three of the foregoing classes of mounting. It is in this section that the greatest skill and ingenuity of the designer is called forth and utilised. Not only may the full capacity of the figuring apparatus be used, but by judicious combinations of mounting very elaborate patterns can be woven which carry the impress of a greater figuring capacity of machine than has actually been employed.

The primary object of complex mounting or distribution of the harness twines in the comberboard is to produce large repeat patterns without a corresponding increase in the figuring capacity of the Jacquard machine—figured stripes composed of single, repeating and turnover sections and double cross border patterns are examples to wit.

When tying up for stripe patterns, the upright hooks of the Jacquard machine are divided into *sections*, the harness cords are tied up to each section of hooks and passed through the comberboard according to the size and form of stripe desired, the design having been previously prepared for each set of hooks.

#### **Harness Mounting—Examples.**

No specific advantage would be gained by adding examples or amplifying the principles of mounting unless each subsequent example from this point possessed some inherent and distinguishing characteristic, or embodied some new principle and special feature.

**Damask Tie,  
with repeating  
centre.**

Fig. 293 shows one row of harness in two 12 row twilling machines, combined and mounted for a cross border damask pattern and a centre containing three repeats of pattern. Each machine contains 51 rows by 12 hooks per row and 25 needles to each row of hooks, for which reason there is a like number of perforations in each row of the comberboard, but these are arranged to run diagonally from the front to the back as shown in the part plan below the lingoes, Fig. 294.

No. 1 machine is set aside exclusively for the centre where three harness twines are tied directly to each upright.

No. 2 machine is devoted absolutely to the borders where two harness twines are tied to each upright. It should be observed that the first twine of No. 1 upright at the left of the machine, is taken across to the extreme left hand side, and the second twine to the extreme right hand side of the comberboard. The first twine of No. 2 upright consequently goes to the left, and the second to the right hand side, and so on throughout the whole series of uprights.

It is important to note, (1) the twist in the harness is on the same side of the loom as the Jacquard machine and clear of all the twines coming from No. 1 machine; (2) the twines of No. 1 upright of No. 2 machine, being nearer to the left side of the comberboard, form a much smaller angle than if first taken straight down to the comberboard for the right border in continuance of the centre, to be afterwards reversed for the left border, which is sometimes inadvertently done.

The border tie is "free," so any border type variety of pattern can be produced, *e.g.*, a unit figure, stripes, double borders interspersed with sateen or plain, at will.

Fig. 295 is a border pattern designed for this type of mounting.

**Cross Border  
Tie, with  
part Single in  
Centre.**

Fig. 296 shows a cross border with a portion of single tie in the centre, suitable for small table "tops." Monograms or private characters may be woven in the centre where the single is shown.

The machine contains 76 rows of needles, 8 deep, making 608 in all. There are three uprights to each needle, as

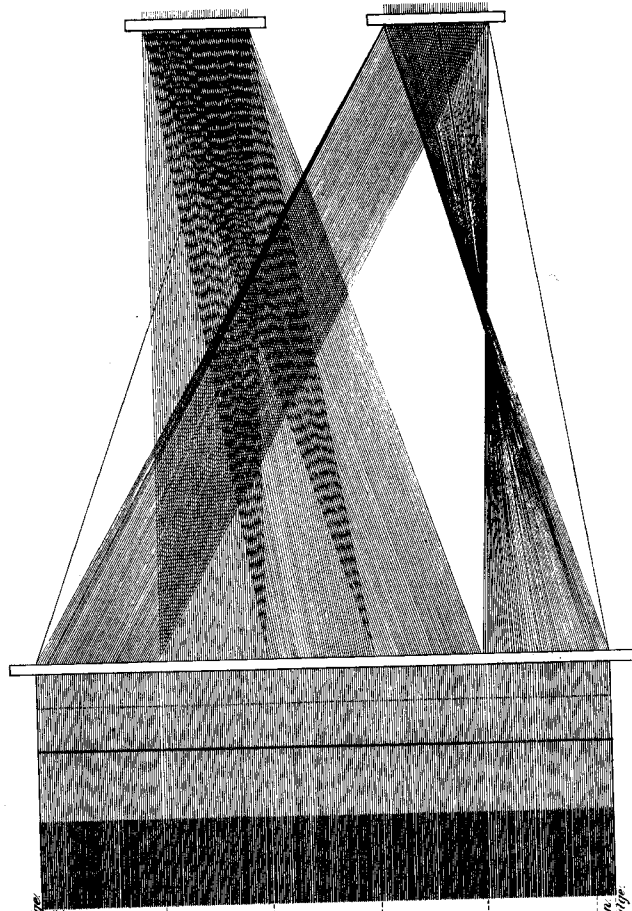


Fig. 293

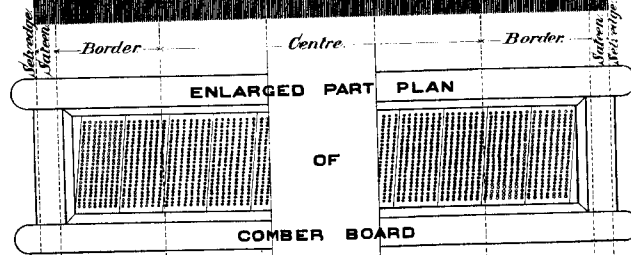


Fig. 294



Fig. 295

shown by the side view of the machine, which thus gives a unit figuring capacity of 1824 uprights, of which 984 are set aside for the borders, and the remaining 840 are devoted to the centre and are tied up "Single." Hence, the complete effect of pattern is distributed over 2808 warp threads—in this example the full width of the warp. The complete details for designing are shown in tabulated form below the illustration.

Fig. 296



DETAILS FOR DESIGNING.				
	<i>Needles.</i>	<i>Hooks.</i>	<i>Cords p. Hook.</i>	<i>Total.</i>
<i>Setv edge.</i>	—	—	—	—
<i>Sateen.</i>	—	—	—	—
<i>Border.</i>	328	984	1X2	1968
<i>Centre.</i>	280	840	1	840
<i>Total Harness Cords in Loom.</i>				2808
<i>Width in Reed 40 inches. Sett 70 ends per in.</i>				

Fig. 297 is a front elevation of the Jacquard machine and first row of mounting.

Fig. 298 shows a side elevation of the twilling hooks.

Fig. 299, a side elevation of the ordinary hooks and their connection with the needles.

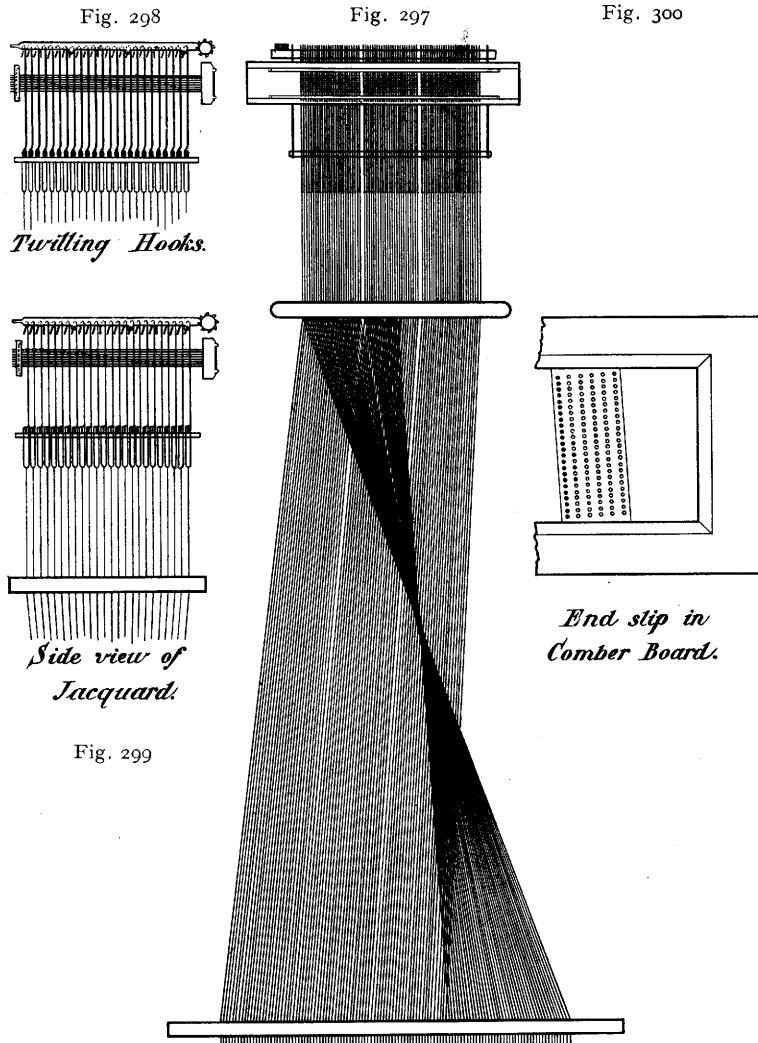


Fig. 300 is a plan of part of the comberboard.

**Damask Tie,  
with Point and  
Single Centre.**

Fig. 301 shows a damask tie for two 612 twilling machines (25 rows of uprights), mounted to produce the maximum variety of effect of pattern with the minimum amount of figuring apparatus. The border twines are taken all from No. 2 machine. It is a free border, but from No. 1 machine 360 uprights are set aside for a point draft and accordingly 360 cords are drawn through the comberboard, in successive and regular order, adjoining the left hand side of the border, but the second set of cords from the same uprights is passed through the board adjoining the right hand side of the border but working, like the first set, gradually towards the centre. The remaining 252 uprights are tied up "single" in the centre of the board, which arrangement facilitates the production of woven designs which at first sight suggest a simple turnover from the centre, but on closer observation it is seen that the design does not turn over from this point and so engenders thought on the part of the observer, and a variety is imparted to a woven product which always commands an increased price, and enhances its choice of selection. Of course the "single" can always be used for monograms or other distinguishing marks which involve mounting.

Fig. 302 shows a suitable pattern designed for this type of mounting.

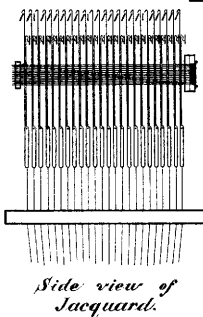
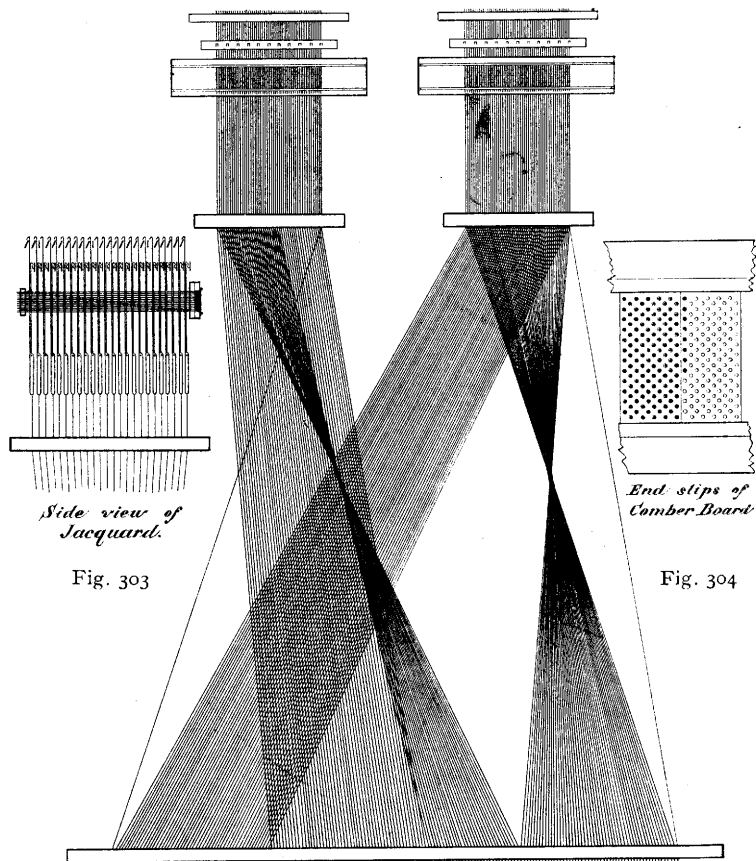
Fig. 303 gives the arrangement of the hooks per needle, and Fig. 304 is a plan of part of the comberboard.

**Apparent Increase in the normal figuring capacity  
of Jacquards.**

The harness mounting for napkins and the cheaper kinds of figured and bordered fabrics has frequently to be so arranged as to produce a figured effect of pattern in the cloth, which appears large in comparison with the figuring capacity of the machine, with which for economical reasons, it must be woven.

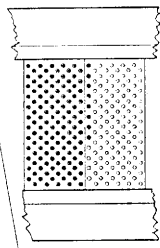


Fig. 301.



*Side view of Jacquard.*

Fig. 303



*End slips of Comber Board*

Fig. 304

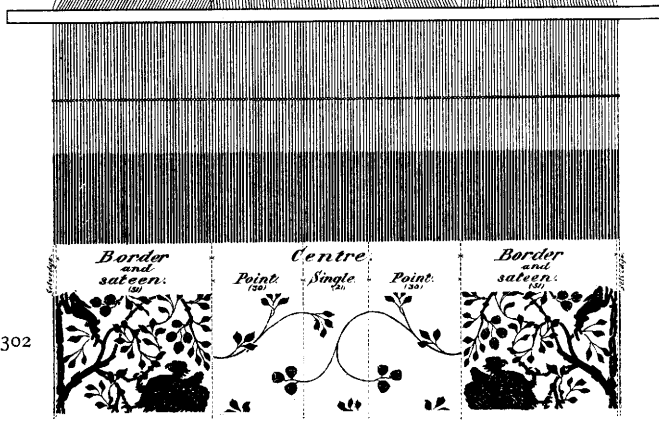


Fig. 302

*Border and sateen.*  
*Point Single.*  
*Point.*  
*Border and sateen.*

**Part Repeat  
of 'Single' in  
Border.**

Fig. 305 shows the complete napkin tie for the first row of hooks in a 304 machine, and Fig. 306 a simple sketch design illustrative of the figuring possibilities of such a mounting. A tabulated distribution of the mounting is set forth below. The selvedge portion A is controlled by 20 cords distributed over 4 hooks; 8 threads of warp sateen B are repeated six times in each border; C once; D—a point tie, twice; E—the special feature, is taken from 88 hooks for which a *single* repeat of a *repeating* pattern is designed; part of this design is then repeated at E<sup>1</sup> with a narrow strip of warp sateen between the two parts E and E<sup>1</sup>. The resultant effect of this modification is to add variety to the complete border pattern, and though the parts E and E<sup>1</sup> are from the same hooks they have a tendency to suggest a difference in effect. F, the centre, contains six repeats of pattern, three only of which are shown. The complete details of this mounting are tabulated as follows:—

BORDER.													CENTRE, 6 Repeats.	
Selvedge.	Warp Sateen.	Warp Sateen.	Warp Sateen.	Point Tie.	Warp Sateen.	Repeat of Part of E.	Warp Sateen.	Single.	Warp Sateen.	Repeat of D.	Warp Sateen.			
4	8	8	—	24	—	—	—	88	—	—	—	176	No. Hooks.	
20	8	32	8	48	8	64	8	88	8	48	8	1056	No. Cords.	
A	B	C	B	D	B	E <sup>1</sup>	B	E	B	D	B			

**Re-arranged  
'Single'  
in border.**

Fig. 307 illustrates a method of mounting a small Jacquard in such a manner as to produce a reasonable amount of variety for so small a machine. The front row of uprights fully mounted and the order of passing the harness cords through the comberboard are also shown. Each subsequent row of hooks is an exact duplicate of the one supplied. Altogether the machine contains 208 figuring hooks, apart from spare hooks for selvedges, etc. The first 96 hooks are

Fig. 305.

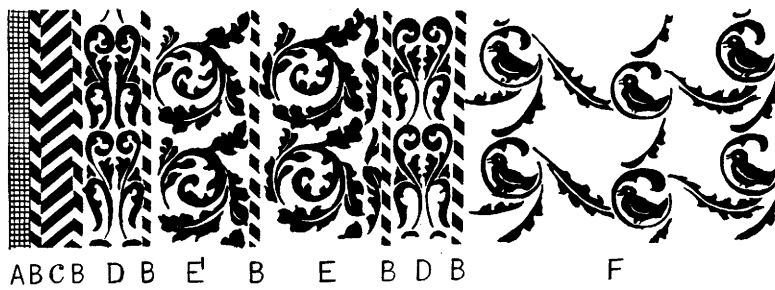
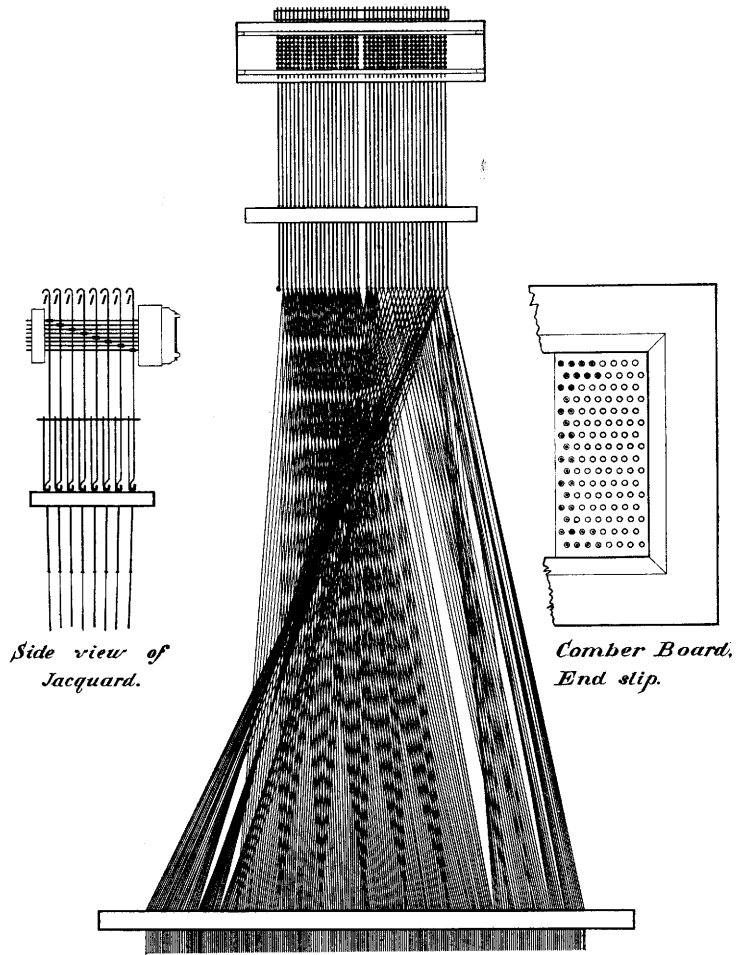


Fig. 306

devoted to weaving the centre A of which there are six full repeats three only of which are shown. The next 96 hooks—97 to 192, are tied up *single* for weaving the border part B which may be of the

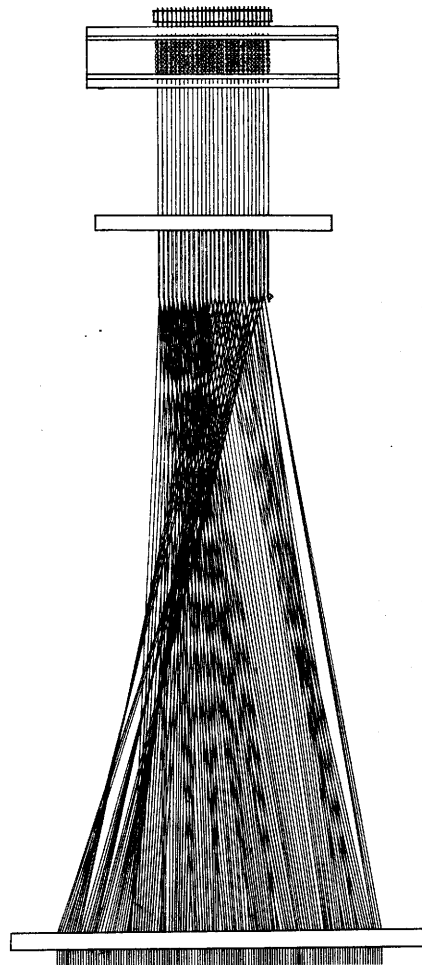


Fig. 307.

single repeating type of pattern; next comes 16 twines from 8 uprights for warp sateen c or other weave; 16 twines are taken from the same hooks and drawn through the comberboard in the

reverse order, after which the single part B in the border is repeated in a modified form as at B<sup>1</sup>. The first harness to be threaded through the comberboard in this part commences with hook 145 and continues to hook 192. Then the next cord is taken from hook 97 and continues to hook 144. This arrangement modifies any repeating figure in such a manner as to impart a changed effect of pattern as at B<sup>1</sup> which feature is illustrated at Fig. 308. The border is completed by 24 cords for the sateen as at D and the selvedge at E.

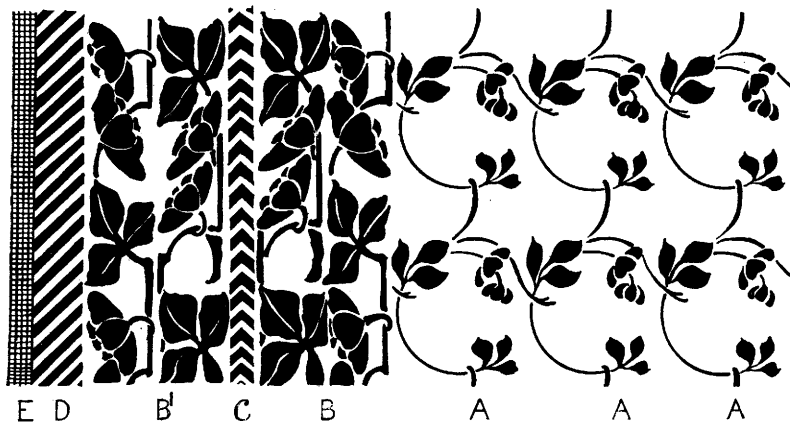


Fig. 308

**Inversion and Repeat of the Point tie in the border.**

An apparent increase in the figuring capacity of any small or other Jacquard machine may be effected as follows :—

Fig. 309 is a plan of one complete repeat of the pattern on a much reduced scale together with a tabulated list of designing details.

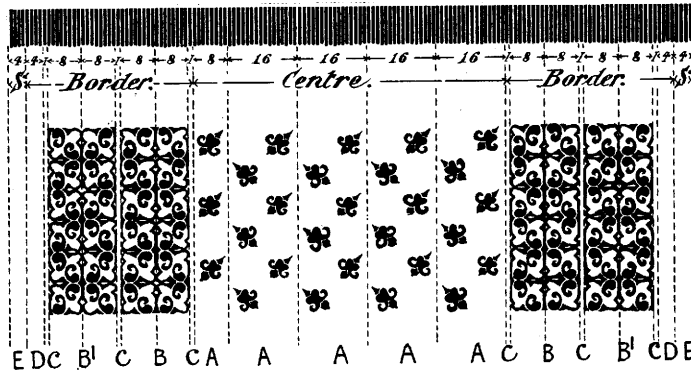
Fig. 310 is a front elevation of the mounting for a 208 machine. The cords from the first and last hooks for each section of the mounting are only shown.

Fig. 311 is a side elevation of the Jacquard and Fig. 312 a plan of part of the comberboard.

The centre A,  $4\frac{1}{2}$  repeats, 576 threads is controlled from hooks 1 to 128 inclusive.

„ part c, warp sateen,	8	„	„	„	„	193 to 200	„
„ „ B, point tie	} 127	„	„	„	„	129 to 192	„
							and back from 191 to 129
„ „ c, warp sateen,	8	„	„			from hooks 193 to 200	„
„ „ B <sup>1</sup> , point tie	} 127	„	„	„	„	191 to 129	„
							and forward from 130 to 192
„ „ c, warp sateen,	8	„	„			controlled from hooks 191 to 200	„
„ „ D, weft sateen,	32	„	„	„	„	201 to 208	„
„ selvages E	— 16	„	are	„	„	from 4 spare hooks.	

Fig. 309.

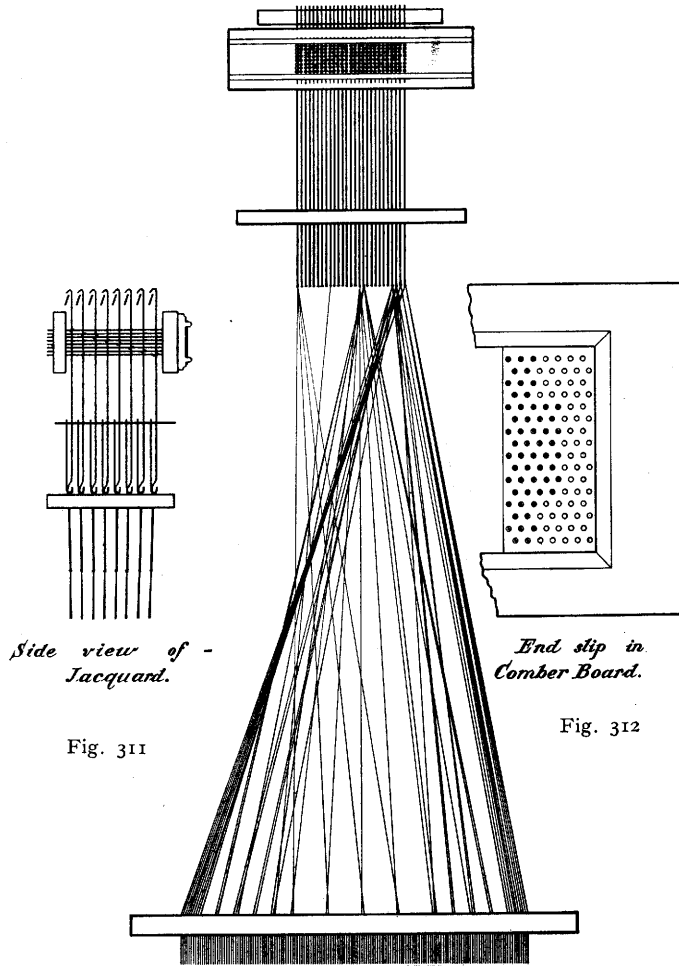


DETAILS FOR DESIGNING.				
	Needles.	Hooks.	Cords p/look.	Total.
Selvedge.	4	4	4x2	32
Border.	Sateen. WFT.	8	4x2	64
	Point.	8	1x3x2	48
Centre	128	128	$4\frac{1}{2}$	576
Total Harness Cords in Loom				1232
Width in Reed				22½". Sett 55 ends p. in.

For the left border the harness cords, from hooks 193 to 208 together with the selvages, are reversed as shown in the mounting.

The special feature of this mounting is in the border sections B and B<sup>1</sup> where the unit pattern idea is doubled as ordinarily by the

point tie and then modified by inversion as at B<sup>1</sup> to give a second



*Side view of -  
Jacquard.*

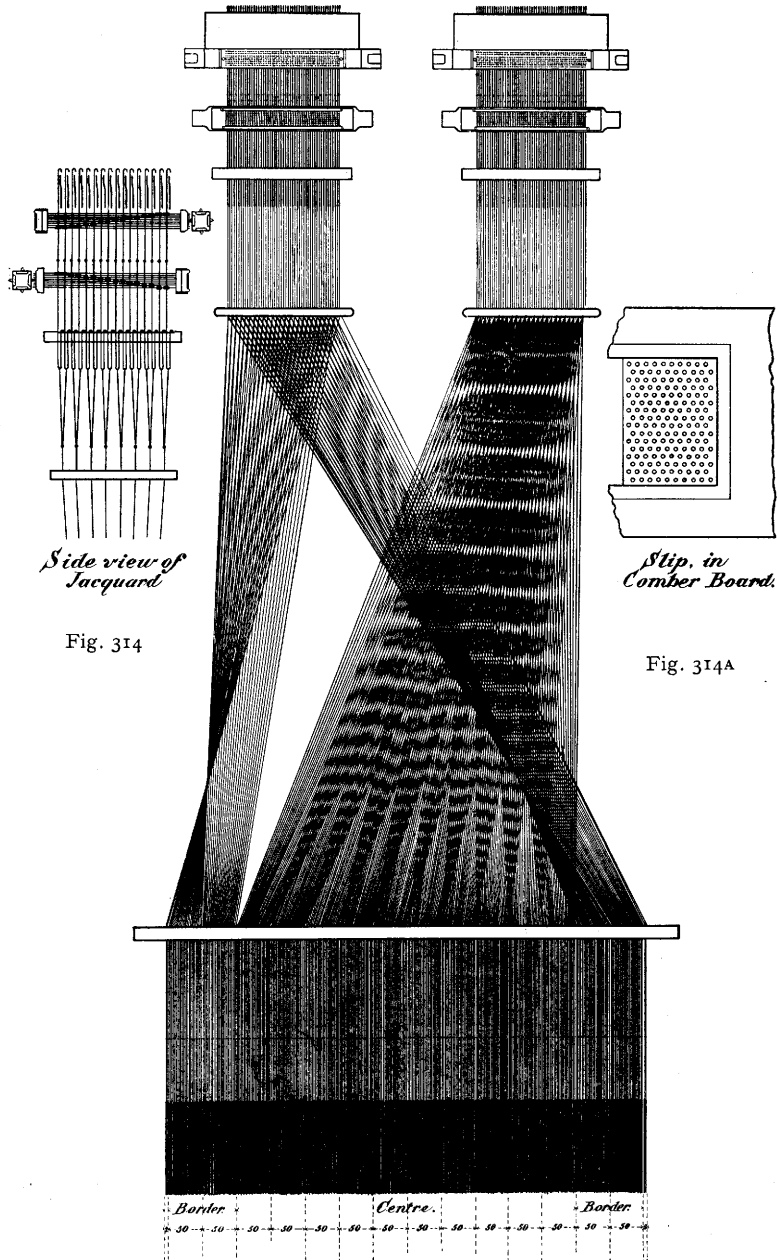
Fig. 311

*End slip in  
Comber Board.*

Fig. 312

Fig. 310.

double effect, and producing as a consequence four times the unit idea in different forms of combinations.





**Point Tie  
Border, with  
Repeating  
Centre.**

Fig. 313 is a front elevation of the complete mounting of two 400 double lift Jacquard machines designed to produce figured patterns for a point tie with repeating centre.

Fig. 314 is a side elevation showing the connection of the hooks and needles, and Fig. 314A a plan of part of the comberboard.

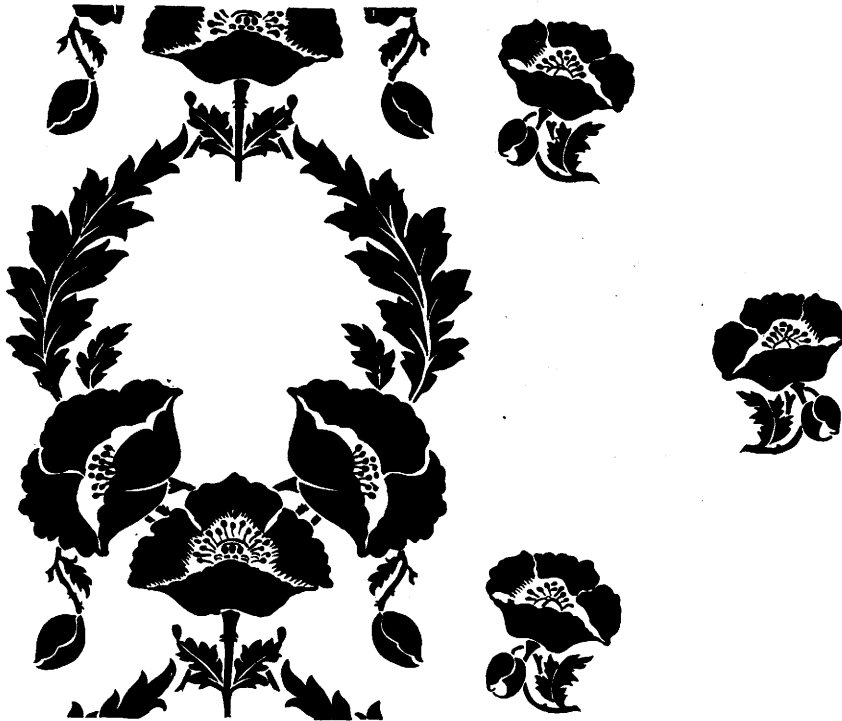


Fig. 315

No. 1 machine is devoted exclusively to control the borders. There are four cords tied to each hook—two for each border. The harness cords are taken from the successive hooks 1 to 400 inclusive, and threaded through the comberboard beginning in the centre of each border and working alternately to the right and left.

No. 2 machine is reserved exclusively for the centre, where the harness cords are taken from hooks 1 to 400 inclusive for ten repeats. The selvages are taken from one row of spare hooks from either or both machines.

The full particulars of mounting are as follows :—Selvages 64 threads, both borders 1600 threads, and centre 4000 threads; total 5664, set 80 cords per inch.

Fig. 315 is a sketch, suitable for the above class or style of mounting.

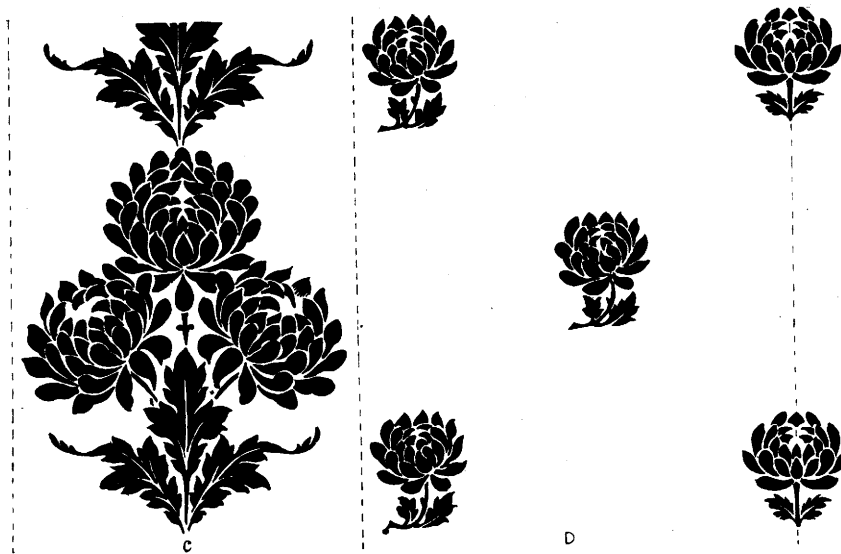


Fig. 316

**Double  
Point Tie.**

Fig. 316 illustrates a type of design which may be woven with this principle of mounting. The main border c is turned over from the centre and produced on 240 hooks and the centre D, also a point tie, is produced on 660 hooks.

This mounting is also well suited to the production of multi-symmetrical patterns with a portion near the outside 'turned over.'

Fig. 317 is a front elevation of the harness tie for a 912 twelve row, fine pitch machine together with the distribution of the harness twines through the comberboard. Four hooks in the first row are set apart to the weaving of the selvages A, the remain-

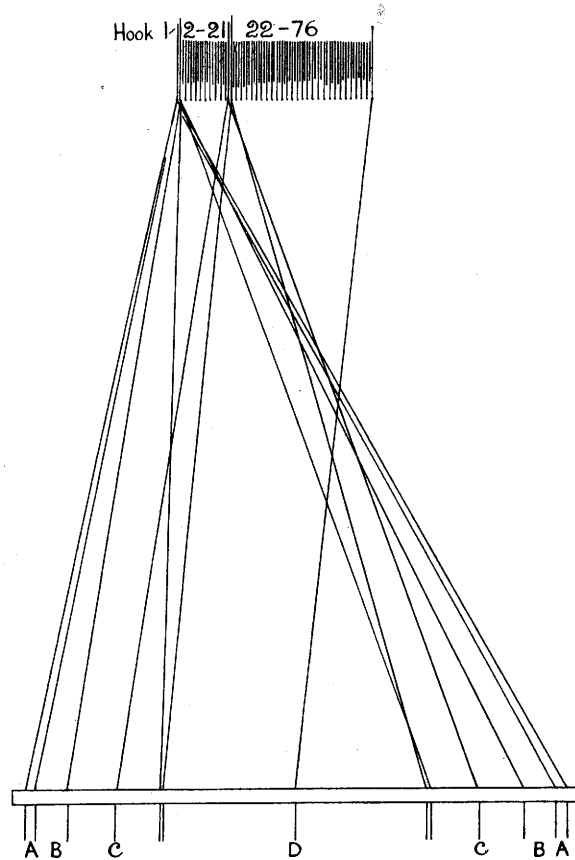


Fig. 317.

ing eight hooks in this row being reserved to work a sateen or other eight-end stripe B. Twenty rows (2 to 21) are set aside to control the borders C. The mounting, from the thirteenth hook, commences in the centre of the border C on the left and then the cords from the successive hooks are threaded, one to the right and one to the left

from hook 13 to 252 inclusive, and similarly for the opposite and right border. The remaining fifty-five rows (22 to 76) are reserved for the body or centre D of the cloth. The mounting for this part is then continued from hook 253 to 912 until the centre of the board and pattern is reached from which point the harness cords are taken from hook 911 to 253 inclusive and threaded through the comberboard to the point where the right hand border joins up to the centre.

It is important to note that the mounting for the foregoing tie is designed so that the harness cords are taken from the hooks 13 to 912 in arithmetical and successive order, *i.e.* from the centre of the left border c to the centre of the filling D; from this point to the centre of the right border c it is reversed. Consequently 1800 threads in the body of the cloth are available for a perfectly multi-symmetrical effect of pattern, virtually composed of 'single' point tie, and suitable for a silk cover or linen or cotton napkin. The remaining outside harness, if not required for figure work, may be lifted clear of the warp, which may then be drawn through special heddles to weave a plain, twill or striped sub-border, when the width of the cloth will, like the original mounting, be suitable for 'table tops.'

The full details of this mounting are tabulated as follows:—

Selvedge A	Left	}	4 hooks	8 cords		Total cords =	32
„	Right		—	8 „		„	32
Sateen B	Left	}	8 hooks	14 „		„	112
„	Right		—	14 „		„	112
Border c	Left	}	240 hooks	2 „	point tie	„	480
„	Right		—	2 „	„	„	480
Centre D			660 hooks	2 „	„	„	1320
							<hr/> 2568

Set 60 cords per inch, 43in. in comberboard.

**Border Pattern** When the figuring capacity of the Jacquard  
**formed from** machine is relatively small in comparison with the  
**Repeating** size of the pattern and cloth required, the following  
**Centre.** method is sometimes adopted.

The Jacquard is tied up for a repeating centre and the border is obtained exclusively, or in part, by 'lifting' a portion of the centre

into the border. The following arrangement sufficiently illustrates the idea. A indicates the figured portion of the fabric.

Selvedge 16 threads.	BORDER.			CENTRE.			Repeat Border.
	Plain 120 threads.	A 560 threads.	Plain 120 threads.	A 600 threads.	A 600 threads.	A 600 threads.	

The following alternative plan is sometimes adopted. The different letters represent differently figured portions and consequently a different set of hooks.

Selvedge 16 threads.	BORDER.				CENTRE.				Repeat Border.
	A 384 threads.	Plain 60 thds.	B 400 threads.	Plain 60 thds.	A 400 thds.	A 400 thds.	A 400 thds.	A 400 thds.	

**Tying up the Harness to serve for two widths of cloth.**

Damask mountings and most border patterns have frequently, for economical reasons, to be tied up in such a way, that the *same* "tie" and pattern cards may be made to serve for two different widths of cloth. It is essential to note the following before proceeding with the mounting for this purpose. (1) Ascertain the two widths of cloth which are most likely to be required for any given set or fineness.

(2) Arrange to always have a complete number of repeats of pattern in the centre without any break.

(3) Contrive to make the number of ends in the repeat of pattern some multiple of the difference in the number of ends between the two widths of cloth required, *e.g.*, an eight inch repeat of pattern and an eight inch difference in width.

(4) Make up small differences in width, say to three inches, by increasing the amount of sateen or selvedges.

*Example 1.* Given  $49\frac{1}{2}$  inch damask containing 45 threads per inch and *five* repeats of pattern in the centre from a 304 machine.

The border pattern is worked from a second 304 machine. Between the border and the selvedge, there is almost one inch of plain or sateen. If it is also required to weave in the same loom and from the same set of cords, a damask  $57\frac{1}{2}$  inches in width, then the harness must be tied up to give six repeats in the centre. It will be evident to the student that the increase in the width of the cloth is 8 inches and that one repeat of pattern in the centre is only equal to  $6\frac{3}{4}$  inches, and therefore the remaining difference must be made up by increasing the amount of plain or sateen, between the selvedge and border, which amount is so slight as to be almost imperceptible.

*Example 2.* The following tabulated grouping of hooks and harness cords is arranged to weave two extreme widths of damask or other cross bordered fabric with two ordinary 400 Jacquard machines. Cloth A is 48 inches wide and cloth B  $64\frac{1}{2}$  inches wide, and both contain 50 threads per inch.

BORDER.						CENTRE. REPEATING-TIE.				
Selvedge	Plain or Sateen	Sheeting Twill	Plain or Sateen	Point Tie	Single					
A 4	8	4	8	88	304	408 = 816 needles				
16	24	44	24	176	304	408	408	408	= 2400 cords.	
B 16	24	44	24	176	304	408	408	408	408	= 3216 cords.

**Mechanism for varying the width of the Harness.** Fig. 318 illustrates a special arrangement designed to adapt the harness to suit two different widths of cloth with the same harness tie. The chief feature is the addition of two short supplementary comberboards, adjustably placed one on either side of the harness.

The tie of the harness is arranged for a bordered fabric with a repeating centre. The pattern in the border is composed of two

sections A and B, arranged A B A B, and worked by hooks 1 to 288 inclusive, followed by six repeats of the centre, controlled by hooks 289 to 600 inclusive, the last row of 12 hooks being reserved for contingencies.

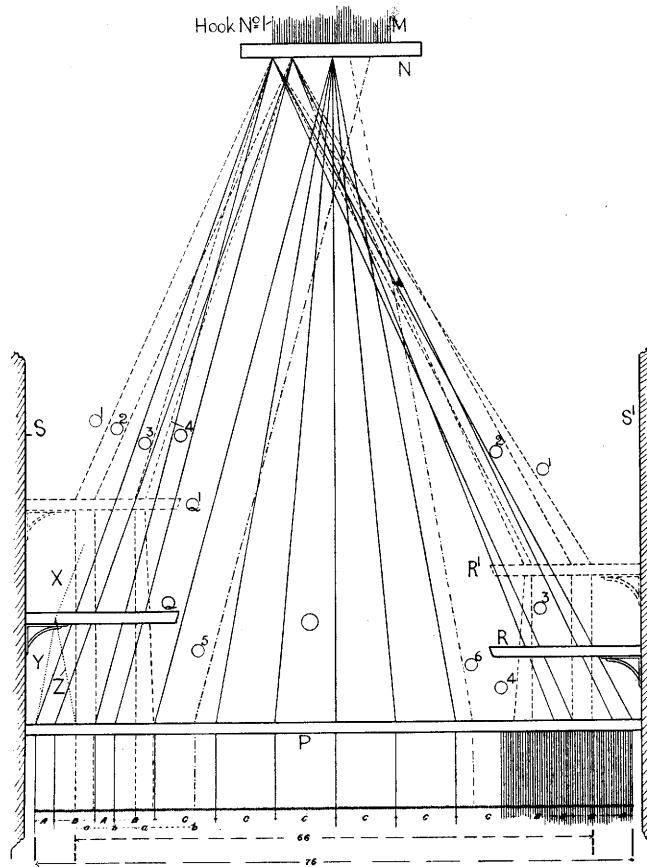


Fig. 318.

It is immaterial whether there be one, two or more machines—the principle of application remains constant.

In the illustration supplied, m indicates the hooks and tug cords, n the tug board, o the harness cords, p the ordinary comberboard,

Q and R the supplementary comberboards, Q<sup>1</sup> and R<sup>1</sup> the same boards in a different position, and s, s<sup>1</sup> the loom gables; the position of the mails and lingoes are as shown.

All the harness cords o for each border are first threaded through their respective supplementary comberboards Q and R, after which they are threaded through the slips of the ordinary and fixed comberboard after the usual manner.

Then, if it is required to weave a cloth narrower in proportion to one or more repeats of the pattern c, it is usual to *lift* the required reduced amount of harness with slips and lingoes, bodily from both sides of the 'centre.' The border harness is then moved close up to the remaining centre harness, the first and last cords of which are shown by the dotted lines o<sup>5</sup> and o<sup>6</sup> respectively. Under ordinary circumstances the mails of the border part would then be lower than those of the centre. In the illustration supplied this difficulty is overcome by raising the supplementary boards Q and R until the harness twines assume the positions as indicated by the dotted lines o<sup>1</sup>, o<sup>2</sup>, o<sup>3</sup> and o<sup>4</sup>, and until all the mails are level. The changed position of the supplementary boards is as shown at Q<sup>1</sup> and R<sup>1</sup>. The new position of the border pattern is shown by the small letters a b a b.

If it is desired, the width of fabric may be reduced by lifting out the harness for section A on the outside or section B on the inside of each border part.

The chief defect of this principle is the acute angles formed in the border harness and the increase of 'strive' on these harness twines; the gain however more than compensates for these objections.

An alternative plan for known changes consists in adjusting the supplementary boards in such a position above the normal board, that the angle in the harness twine between the two boards Q and P is the same for both widths of harness. This modification is illustrated by the dotted lines x y z, where x is the harness cord above the supplementary board Q; y the same cord below the board for the wider width, and z its new position for the narrower width.



**The Necessity and Use of the Heck.**

The heck is used as an accessory to the Jacquard machine whenever the harness is tied up for wide widths.

It is extensively employed in linen damask weaving.

Its purpose is to assist in the production of an equal depth of warp shedding from selvedge to selvedge, and also to insure the same vertical pull in the harness and tug cords as is imparted to the hooks.

The heck is in the form of a grate ; it consists of a number of steel or wooden bars, set equidistant and supported in a wooden frame. A number of wood rollers equal to the number of rows of uprights, are frequently placed at right angles and above the steel bars to keep each row of harness separate and distinct, and from swaying to and fro during working.

The dimensions of the heck must be slightly larger than the plan of the tug cords, for the whole machine, but the divisions must be so arranged as to permit the tug cords to rise and fall in a vertical plane. It should be placed two or three inches immediately below the bottom of the tug cords and near the top of the harness cords.

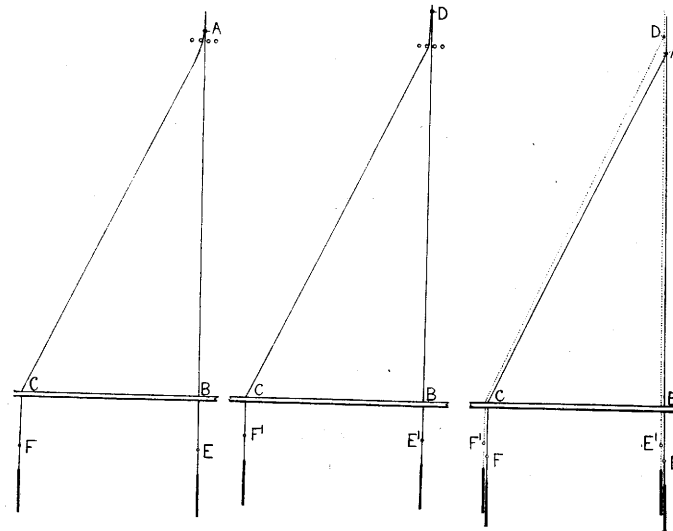
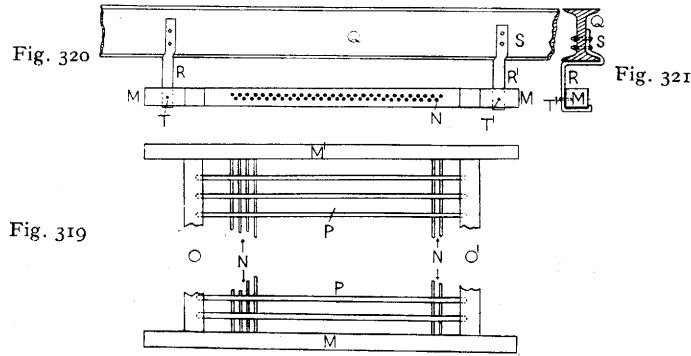
The excessive friction generated between the harness cords and the steel rods of the heck constitute its chief defect.

**Heck Mechanism.** Fig. 319 is a plan of a heck as used for a 612 twilling machine. *m* and *m'* are the front and back wood rails, between which two rows of steel wires *n* are fixed. The main rails *m* and *m'* are combined, at right angles, by wood rails *o* and *o'* supported between which and free to rotate are wood rollers *p*, which pass freely between each longitudinal row of harness.

Fig. 320 shows a front elevation and Fig. 321 an end elevation of the heck as adjusted to the Jacquard gantry *q*. Special hooked brackets *r* and *r'* are bolted to the gantry by bolts *s*, as shown.

The heck is adjusted to the suspended brackets *r* and *r'* by bolts *t* and *t'* and their duplicates at the rear side of the loom.

Fig. 322 is a graphic representation of the distances between the tug board and the centre and side of the comberboard, when a



Figs. 323 324 322

heck is *not* used. A.B, equals the distance from the tug knot to the middle of the comberboard; A.C, the distance from the same tug knot to the outside harness cord through the comberboard; A.D, the

lift of the hook and tug cord; E the normal position of the mails below the centre of the comberboard; F the normal position of the *outside* mail. E<sup>1</sup> and F<sup>1</sup> indicate their relative changed position when the Jacquard head is lifted to the top.

Fig. 323 shows the same details when the harness is at the bottom and when the heck is used.

Fig. 324 shows the same parts when the harness is lifted and the heck is used. It will thus be seen that the mails of the harness, both at the centre and the side, are at the same level.

**Hecks Adjustable.** The heck should be fixed in such a manner that it can be readily adjusted or fixed to adjustable brackets, for two reasons; *first*, that it may be lowered considerably to admit of repairs to the harness, and *second*, because the harness occasionally varies in length, due to atmospheric changes which, unless neutralised, tends to produce a defective shed; an adjustable heck may be raised or lowered at will so as to act on the harness and mails to suit the 'race' of the 'going part.'

As an alternative method, the sword of the 'lay' is sometimes made in two parts, which being adjustable may be raised or depressed to suit the level of the warp threads.

**Heck Problems.** *Example 1.*—Assume the width of the harness in the comberboard is 90 inches, the distance from the centre of the comberboard to the tug cord, in its lowest position, is 90 inches, and the lift of the Jacquard head and knives is 4 inches.

Find the lift of the harness cord in the comberboard at 45 inches from the centre of the same, as in Fig. 322.

Then by Prop. 47, Book I, Euclid:

$$\begin{aligned} AB^2 + BC^2 &= AC^2 \\ &= (90 \times 90) + (45 \times 45) = AC^2 \\ \therefore AC^2 &= (8100 + 2025) = 10125 \\ \text{and } AC &= \sqrt{10125} = 100.6'' \\ \text{also } CD^2 &= CB^2 + BD^2 = (45 \times 45) + (94 \times 94) \\ \therefore CD &= \sqrt{2025 + 8836} = \sqrt{10861} = 104.2'' \\ \text{and } 104.2'' \text{ (CD)} - 100.6'' \text{ (AC)} &= 3' 6'' \end{aligned}$$

= the distance which the mail F rises as compared with mail E which travels the full distance of the lifting hook, viz :—4 inches.

*Example 2.*—Given the perpendicular distance from the tug cord to the comberboard as 60 inches, the width of the harness in the comberboard is 96 inches. If the head of the Jacquard machine rises 4 inches, find the reduced distance which the mail rises at the edges as compared with the mails in the centre of the comberboard.

*Hypotheses.*

Let AD = 60", the perpendicular distance from the tug cord to the comberboard.

and AB = the diagonal distance from the tug cord to the extreme harness cord.

also BD = 48", being half the width of the harness.

and AE = 4", the distance travelled by the tugs.

*Solution.*

$$\text{Eq. (1) } AB^2 = AD^2 + BD^2 = 5904$$

$$\text{Eq. (2) } EB^2 = ED^2 + BD^2 = 6400$$

$$\text{Eq. (1) } AB^2 = \sqrt{5904} = 76.83''$$

$$\text{Eq. (2) } EB^2 = \sqrt{6400} = 80$$

Then  $80 - 76.83'' = 3.17''$ , the distance which the extreme harness cords elevates the warp thread as compared with 4 inches in the centre of the comberboard.

The student should make a line diagram, lettered to correspond with the above hypothesis, to prove this example.

## CHAPTER XIX.

### Harness Mounting—Problems.

*Example 1.*—A Jacquard machine has a capacity of 400 needles and uprights. If there are 80 harness cords per inch, and 60 inches wide in comberboard, find the number of harness cords to be attached to the tug cord of each upright, the number of repeats of pattern, and size of each repeat.

Then the number of harness cords per hook and repeats of pattern

$$= \frac{\text{Harness cords per inch} \times \text{width}}{\text{Capacity of machine}} = \frac{80 \times 60}{400} = 12.$$

The size of each repeat of pattern

$$= \frac{\text{Capacity of machine}}{\text{Cords per inch}} = \frac{400}{80} = 5 \text{ inches.}$$

*Example 2.*—A finished figured fabric having a pattern which occupies  $3\frac{1}{2}$  inches, counts 86 threads per inch. Ascertain the capacity of the Jacquard machine which was employed to produce this design.

Then the product of the ends per inch and the repeat of pattern in inches is equal to the capacity of the machine, thus :—

$$86 \times 3\frac{1}{2} = 301, \text{ apparently a 304 Jacquard machine.}$$

*Example 3.*—Given a warp containing 3560 ends 16s reed 4s, with 80 cords for selvages taken from 1 row of hooks, and  $8\frac{1}{2}$  repeats of pattern tied to the remaining 400 hooks. Ascertain (a) the width of harness in comberboard; (b) the size of repeat of pattern.

Then (a)  $\frac{\text{Total ends or cords}}{\text{Ends or cords per inch}} = \frac{3560}{64} = 55\frac{5}{8}''$  wide.

and (b)  $\frac{\text{Capacity of machine}}{\text{Ends per inch}} = \frac{400}{64} = 6\frac{1}{4}''$  in one repeat of pattern.

*Example 4.*—Ascertain the number of harness cords tied to each hook in a Jacquard machine mounted for weaving borders thus :— 1 row for edges, 25 rows for border, 25 rows for centre, 408

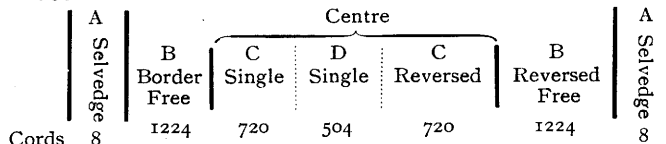
machine, 60 harness cords per inch, and width of harness 72" distributed as follows:—1 inch for each edge, 10 inches for each border, 50 inches for centre.

$$\text{Edges } 1 \times 2 \times 60 = 120 \therefore \frac{120}{1 \times 8} = 15 \text{ harness cords to each hook.}$$

$$\text{Borders } 10 \times 2 \times 60 = 1200 \therefore \frac{1200}{25 \times 8} = 6 \text{ harness cords to each hook.}$$

$$\text{Centre } 50 \times 60 = 3000 \therefore \frac{3000}{25 \times 8} = 15 \text{ harness cords to each hook.}$$

*Example 5.*—Given harness mounting as below, find the required number of twilling machines and capacity. Set 60 threads per inch and 73½ inches wide.



Assume 2 uprights to each needle, then:—

$$\text{Border} = \frac{\text{Uprights}}{\text{Hooks per Needle}} = \frac{1224}{2} = 612 \text{ needles, No. 1 machine.}$$

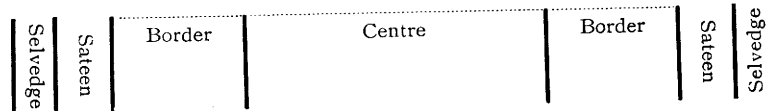
$$\text{Centre} = \text{Do.} = \frac{720 + 504}{2} = 612 \text{ needles, No. 2 machine.}$$

*Example 6.*—If two twilling Jacquards, each containing 612 needles and 25 uprights to each row of 12 needles, be mounted as tabulated below, with 85 harness cords per inch in comberboard, find (a) the full width of the harness; (b) the width of the selvedge, sateen and ‘free’ border on each side of the woven fabric; (c) the size of each repeat of pattern in the centre, together with the full width of centre.

DETAILS FOR DESIGNING.

	Needles.	Uprights.	Cords to each Hook.	Harness Cords.
Selvedge .. ..	2	5	(3 × 20) + (2 × 30)	120
Sateen .. ..	10	20	5 + 5	200
Border .. ..	600	1250	1 + 1	2500
Centre .. ..	612	1275	3	3825

Total Harness Cords 6645



- (a)  $\frac{\text{Total harness cords}}{\text{Cords per inch}} = \frac{6645}{85} = 78$  inches.
- (b) Each Selvedge  $\frac{120}{2 \times 85} = \frac{12}{17}$ "
- „ Sateen  $\frac{200}{2 \times 85} = 1\frac{1}{8}$ "
- „ Border  $\frac{2500}{2 \times 85} = 14\frac{3}{8}$ "
- (c)  $\frac{3825}{85 \times 3} = 15$ " repeats of pattern,  $15" \times 3 = 45"$  = width of centre.

**Varying the Set of the Harness, Fineness of Cloth and Size of Pattern.**

The great variety of different degrees of fineness in woven fabrics frequently necessitates a modification in the fineness or set of the harness.

Any modification of the harness after it has been mounted, must of necessity be in the direction of reduction in fineness, if the system of mounting and style of pattern are to be retained. This modification is technically known as 'casting-out.' It is resorted to

1. When the set in the harness is finer than the requirements of the cloth to be produced.
2. When the number of ends in one repeat of the design is not divisible into the number of hooks which represents the figuring capacity of the machine.
3. When an increased size of pattern is required, a reduction, pro rata, in the fineness of the texture is involved, but a retention and use of all the hooks in the Jacquard machine.

**Casting-out.** *Casting-out* may be accomplished in the following ways :—

1. The surplus mails may be cast out in rows across the full width of the comberboard. Thus a 12 row machine may be reduced to a 10 or 8 row ; an 8 row machine may be reduced to a 7 or 6, according to circumstances (preferably to 6 rows).

2. The method usually adopted is to leave complete vertical rows of needles and corresponding hooks idle, and to 'cast out' the warp threads from the mails connected with the hooks and needles which are to remain idle.

Both these methods reduce pro rata the figuring capacity of the Jacquard machine.

It is important to note that the rows of hooks and mails cast out, should be evenly distributed over the whole of the machine so as to avoid any undue friction in the warp yarn between the mails and the reed at the places where the mails are standing idle.

3. A very good method is to cast out 1 or more harness mails connected with each neckband or upright in the Jacquard machine. The chief feature in this system of casting out, is that it retains the full figuring capacity of the machine—the 'set' only being reduced according to the requirements of the fabric.

4. When only a slight difference in the set is required and when a variation in the width of the piece of 1 to 1½ inches does not matter, it is sometimes advisable to sley the warp into a finer or coarser reed. The defect of this method is that it generates friction upon those warp threads nearest the edges.

5. If the comberboard is in slips, a slightly modified increase of width and reduction of set can be obtained, by the simple insertion of plain narrow pieces of wood between the divisions of the perforated slips. Any increase in the width of more than 3 or 4% interferes too much with the level of the harness.

*Example 1.*—The figuring capacity of a 12 row Jacquard machine is 600. The harness is mounted with 80 cords per inch. It is required to reduce the set to 72 cords per inch. To what extent will this change reduce the figuring capacity of the machine and in what order should the uprights be left idle.

$$\text{Reduced figuring capacity} = \frac{\text{Standard capacity} \times \text{reqd. set}}{\text{Standard set}} = \frac{600 \times 72}{80} = 540.$$

$$\text{No. of uprights to cast out} = 600 - 540 = 60.$$

$$\text{Order of casting out} = \frac{\text{Total uprights}}{\text{Uprights to cast out}} = \frac{600}{60} = \frac{10}{1}$$

∴ 1 row to cast out in every 10 rows.



*Example 2.*—A small pattern complete on 80 threads of warp and weft is woven in an 8 row 400 Jacquard machine with 60 harness cords per inch. It is required to reduce the fineness of the cloth from 60 to 48 ends and shots per inch but retain the same size of pattern. (1) What number of threads of warp and weft would the pattern occupy? (2) What would be the reduced capacity of the machine? (3) How many hooks should be cast out? and (4) How should they be distributed?

$$(1) \begin{array}{ccccccc} \text{Given Set} & : & \text{reqd. Set} & : & \text{Ends in} & : & \text{Ends in} \\ & & & & \text{given pattern} & : & \text{reqd. pattern.} \\ \therefore 60 & : & 48 & : & 80 & : & 64 \text{ ends and shots.} \end{array}$$

$$(2) \begin{array}{ccccccc} \text{Original Set} & : & \text{reqd. Set} & : & \text{full capacity} & : & \text{reqd. capacity.} \\ \therefore 60 & : & 48 & : & 400 & : & 320 \end{array}$$

$$(3) \begin{array}{r} \text{Full capacity} - \text{required capacity} = \\ 400 \quad \quad \quad - \quad \quad \quad 320 \quad \quad \quad = 80 \text{ hooks to cast out.} \end{array}$$

$$(4) \frac{\text{Full capacity}}{\text{Uprights idle}} = \frac{400}{80} = \frac{5}{1}$$

$\therefore$  Cast out one row of uprights in every 5.

*Example 3.*—In a 400 machine, mounted with 80 harness cords per inch, 32 inches wide, 256 harness cords are cast out without reducing the capacity of the figuring harness. Find the reduced set and the size of pattern in each case.

$$\frac{80 \times 32 - 256}{32} = \frac{2304}{32} = 72 \text{ set or cords per inch.}$$

$$(1) \frac{400}{80} = 5 \text{ inches in 1 repeat of pattern.}$$

$$(2) \frac{400}{72} = 5\frac{5}{8} \text{ " " " "}$$

### Suitable sizes of Point Paper and Shots per Card for Ordinary and Twilling Jacquards.

The size of point paper for ordinary Jacquard machines varies directly in proportion to the ends and picks per inch.

*Example 1.*—Required a fabric to contain 80 ends and 60 shots per inch finished, find the number of ends and shots which the design paper must be ruled so that the design, when woven, will not be distorted, but proportional to the sketch.

$$\therefore \frac{\text{Ends on paper}}{\text{Shots on paper}} = \frac{80 \text{ ends in warp}}{60 \text{ shots of weft}} = \frac{8}{6} \text{ for 8 row machines.}$$

$$\text{or } \frac{12}{9} \text{ for 12 row machines.}$$

The foregoing problem is simple and the solution self-evident, but for more complex problems the following method will be found to admit of general application.

Let  $x$  = the relative number of picks to ends in the point paper.

$$\text{Then } \frac{\text{Ends per inch}}{\text{Picks per inch}} = \frac{\text{Needles per row in needle board}}{x} = \frac{\text{Ends on point paper}}{\text{Picks on point paper}}$$

Applied to the above problem, for a 12 row machine.

$$\begin{aligned} \text{Then picks per square of ruled paper for a 12 row machine} \\ = \frac{80}{60} = \frac{12}{x} \therefore x = \frac{60 \times 12}{80} = 9. \end{aligned}$$

*Example 2.*—A silk fabric is woven in a reed containing 2400 splits, 2 threads in a split, in a width of 30 inches. Assuming the fabric must contain 100 picks per inch of weft, what size of point paper must be used for an 8 row Jacquard machine ?

$$\text{Then } \frac{\text{Ends per inch}}{\text{Picks per inch}} = \frac{\frac{2400 \times 2}{30}}{\frac{100}{1}} = \frac{8}{x} \therefore x = \frac{8 \times 100 \times 30}{2400 \times 2 \times 1} = 5$$

Where  $x$  = the relative number of picks to ends in the point paper.

*Example 3.*—A silk fabric contains 1600 splits, 2 threads in a split, in a reed width of 21 inches and 120 picks per inch, what sizes of point paper are most suitable to avoid any distortion of the woven figure? A for an 8; B for a 12 row machine.

$$\text{Then } A = \frac{\frac{1600 \times 2}{21}}{\frac{120}{1}} = \frac{8}{x} \therefore x = \frac{8 \times 120 \times 21}{1600 \times 2} = 6\frac{3}{10}$$

Approximately  $\frac{8}{6}$  paper.

$$\text{and } B = \frac{\frac{1600 \times 2}{21}}{\frac{120}{1}} = \frac{12}{x} \therefore x = \frac{12 \times 120 \times 21}{1600 \times 2} = 9\frac{9}{10}$$

Approximately  $\frac{12}{9}$  paper.

Note.—When designing for twilling machines each end on the point paper represents as many threads of the pattern as there are uprights controlled by each needle, and each weft line on the point paper represents as many shots as the card strikes before the cylinder turns.

Other factors remaining constant, an increase in the number of uprights per needle involves a corresponding increase of shots per card and vice versa.

*Example 4.*—A finished web is to contain 90 ends and 150 shots per inch. There are 3 uprights to each needle and 2 shots to each card. Find the relative number of ends to shots on the point paper to prevent any distortion of the pattern when woven.

Then the warp threads will be relatively increased with the shots per card and the weft divisions in proportion to the number of uprights per needle, thus :—

*Formula* —

$$\begin{aligned} \frac{\text{Ends} \times \text{Shots per Card}}{\text{Shots} \times \text{Uprights per needle}} &= \frac{\text{Ends on point paper.}}{\text{Shots on point paper.}} \\ &= \frac{90 \times 2}{150 \times 3} = \frac{2}{5} = \frac{8}{20} \text{ for 8 row cylinder.} \\ &= \frac{12}{30} \text{ for 12 row cylinder.} \end{aligned}$$

*Example 5.*—Design paper is required for a twilling Jacquard, 24 hooks to each row of 12 needles, and 2 shots to each card. Finished web contains 80 ends and 120 shots per inch.

Obviously 24 hooks to 12 needles equals 2 hooks per needle. Then proceeding as per formula above.

$$\frac{80 \times 2}{120 \times 2} = \frac{2}{3} \text{ or } \frac{12 \text{ ends.}}{18 \text{ shots.}}$$

*Example 6.*—It is required to weave a pattern to finish 80 ends and shots per inch with a set of cards which were previously used for a cloth containing 80 × 120 ends and shots and woven alternately 4 and 5 picks per card, what shots per card are necessary and also state the number of uprights there are to each needle.

1. Obviously the variation of shots per card will be in direct proportion to the shots in the two cloths, thus :—

Let x = the shots per card in the required cloth.

$$\text{Then as } 120 : 80 :: \frac{5 + 4}{2} : x.$$

$$\therefore x = \frac{5 + 4}{2} \times \frac{80}{120} = 3 \text{ shots.}$$

2. And, since the ends and shots per inch with the 3 shot cards are equal, the number of uprights to each needle must be the same.

*Example 7.*—Given a design on  $12 \times 12$  paper for a damask which is to contain 80 ends and 120 shots per inch, bleached. If the twilling Jacquard machine contains 24 hooks to 12 needles, find the number of shots per card necessary to avoid any distortion of the pattern when woven.

Let  $x$  = Shots per card.

$$\text{Then as } \left. \begin{array}{l} 80 : 120 :: 1 : x \\ 12 : 24 :: \end{array} \right\} \therefore x = \frac{1 \times 120 \times 24}{80 \times 12} = 3$$

### Exercises.

1.—A Jacquard harness is mounted with 7 cords to each upright, the capacity of the machine is 240 hooks, there are 64 cords per inch in the comberboard, find the full width of the harness in same, exclusive of edges; also ascertain the size of one repeat of pattern.

Ans.,  $26\frac{1}{4}''$ ;  $3\frac{3}{4}''$ .

2.—Given a single lift Jacquard machine containing 240 uprights with 8 needles in each row of the needle board, if the harness be set over 28 inches including one inch for selvages, which latter cords are taken from the last row of hooks, find (a) the number of repeats of pattern and the harness cords required to each tug cord; (b) the size of each repeat of pattern, when the set is 72 cords per inch.

Ans., 9 approx.;  $3\frac{2}{3}''$ .

3.—Given 80 harness cords per inch for a 600/12 row machine. Find rows per inch in comberboard.

Ans.,  $7\frac{1}{2}$  or 15 per every 2 inches.

4.—Assume that a reed contains 56 threads per inch, and the Jacquard 8 needles per row, give the most suitable method of boring the slips for the comberboard.

Ans., 14 rows of 8 each in a 2" slip.

5.—Arrange a tie on two Jacquard machines of 612 hooks each, for a damask with 75 threads per inch;  $77\frac{1}{4}''$  reed space. There must be a border at both sides of the cloth.

6.—A hand loom is mounted with a single lift Jacquard containing 208 upright hooks. 8 hooks are set aside for the selvages, and 200 for the body of the fabric. The mounting is tied up on the

“Split Harness” principle, *i.e.*, each harness supports two mails and lingoos.

There are 10 harness cords connected to each selvage hook to work both edges, and 6 harness cords to the first hundred hooks, and 5 harness cords to the second hundred hooks. Find the total number of individual warp threads which can be operated, and width of the same in the comberboard, when the set is 160 threads per inch. Ans., 2360.  $14\frac{3}{4}$ "

7.—Assuming the lift of the Jacquard head is  $3\frac{1}{2}$ ", the distance between the tug cord and the comberboard is 84", the width of the harness is 78"; find the greatest amount of difference of lift at the mails of the harness, when the heck is not used. Ans., 0·3".

8.—Given a 400/8 row machine, 80 set, cast 2 longitudinal rows of needles out. Find the set. Ans., 60.

9.—A fabric is woven in 60 set Bradford; 32 inches wide. It is required to produce a cloth in the same harness without casting out, but in 58 set. Find the width. Ans., 33·1".

10.—It is required to weave a design occupying 20 threads, on a 304, 408, 510 or 612 machine. Ascertain how many hooks should be cast out in each machine to obtain a perfect repeat at each division of the harness. Ans., 4; 8; 10; 12.

11.—Given a Jacquard machine with a capacity of 384 hooks; the size of each repeat in the comberboard is 3 inches; it is required to weave a design in a cloth containing 96 ends per inch; how many hooks must be cast out, and how should they be distributed?

Ans., 96. 1 row out every 4.

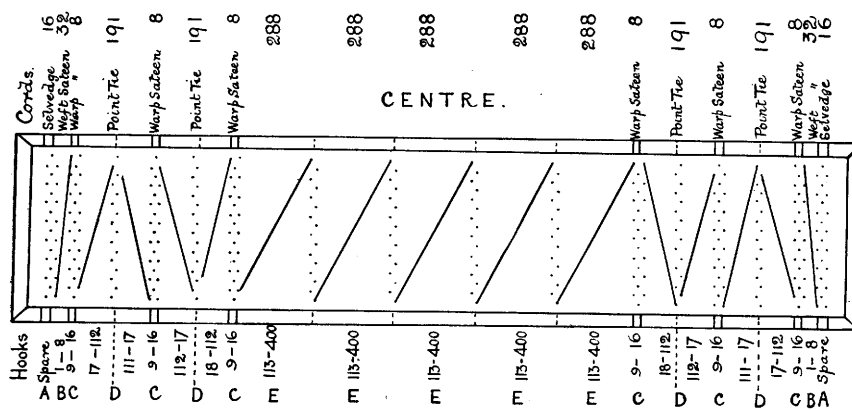
12.—A Jacquard machine contains 408 hooks, and is tied up to 90 ends per inch; it is required to weave a pattern having 72 ends per inch. How many hooks would you cast out, and how would you distribute them?

Ans., 82, preferably 80; 1 row out of every 5.

13.—A napkin design consists of a pattern which is complete on 184 threads, and repeated three times in the centre of the cloth; there is also a turn over side border of 240 threads. What capacity of Jacquard would be required to weave the cloth. Ans., 304.

14.—Fig. 325 is a plan of a “marked off” comberboard to particulars given therewith. Ascertain (1) the capacity of the machine, (2) the total harness cords and ends of warp, and (3) the width of the harness in the “board,” and the warp in the reed.

Ans., 400; 2348; 42”.



56 harness cords per inch.

Fig. 325

15.—What point paper would you use to paint a design for a cloth containing 80 threads to the inch in warp, and 160 threads to the inch in weft?

Ans., 8 × 16.

16.—What ruling of point paper would be required for a cloth counting when finished, 60 warp and 80 weft threads per inch, if woven in (1) 400; (2) 500; (3) 600 machines?

Ans., 8 × 11; 10 × 13; 12 × 16.

17.—What ruling of design paper should be used for a design 6 inches square, to be woven in a cloth containing 68 ends and 48 picks per inch?

Ans., 8 × 6.

18.—What point paper would be required to paint a design for a 600, 8 row twilling Jacquard, 3 hooks to needle and 3 shots to card, cloth to count 70 ends and 108 picks per inch?

Ans., 8 × 12.

19.—Give suitable rulings of design paper to suit :—(a)  $50 \times 35$ ;  $40 \times 30$ ;  $30 \times 35$ ; ends and picks per inch for a 300, 8 row machine. (b)  $55 \times 60$ ;  $60 \times 40$ ;  $50 \times 45$ ;  $45 \times 40$ ; ends and picks per inch for a 400, 8 row machine. (c)  $70 \times 90$ ;  $65 \times 80$ ;  $80 \times 85$ ; ends and picks per inch for a 500, 10 row machine. (d)  $85 \times 100$ ;  $80 \times 110$ ;  $70 \times 95$ ;  $90 \times 135$ ; ends and picks per inch for a 600, 12 row machine.

Ans., (a)  $8 \times 6$ ;  $8 \times 6$ ;  $8 \times 9$ . (b)  $8 \times 9$ ;  $8 \times 5$ ;  $8 \times 7$ ;  $8 \times 7$ . (c)  $10 \times 13$ ;  $10 \times 12$ ;  $10 \times 11$ . (d)  $12 \times 14$ ;  $12 \times 16$ ;  $12 \times 16$ ;  $12 \times 18$ .

20.—A design which has been painted for two, 300, 8 row machines is to be woven by a 600, 12 row machine, what re-ruling of the design paper will be necessary?

Ans., ruled 12s instead of 8s.

21.—A pattern is painted on  $50 \times 50$  squares of  $8 \times 12$  paper, for a cloth counting 50 ends and 80 picks per inch, what will be the size of the repeat in the cloth?

Ans., 8in.  $\times$   $7\frac{1}{2}$ in.

22.—A set containing 2700 pattern cards is weaving a damask cloth, 72 inches long, counting 90 ends and 150 shots per inch, in a loom with two, 600, 12 row twilling machines, 3 hooks per needle; what ruling of point paper should the design be painted on?

Ans.,  $12 \times 15$ .

23.—A sketch measuring 10 inches wide by 8 inches long, is to be transferred to design paper for a cloth counting  $60 \times 70$  threads per inch, to be woven by a 600 machine; how many squares of point paper will be required, and what will be the ruling of each square?

Ans.,  $50 \times 40$ ;  $12 \times 14$ .

24.—A Jacquard is filled with 384 hooks and mounted with 16 harness cords to each hook, distributed over a width of 35 inches in the comberboard. It is desired to weave a pattern with 72 ends in each repeat in a fabric containing 132 threads per inch over a width of 32 inches. Ascertain the number of hooks to cast out, and state how they should be distributed.

Ans., 96; 1 row out of 4.

25.—A Jacquard is mounted with 2 hooks to each needle, and the pattern has to be woven with 2 and 3 shots per card alternately; the finished fabric must contain  $100 \times 150$  ends and picks per inch.

What ruling of design paper must be employed for a 12 row machine ?

Ans.,  $12 \times 14$ .

26.—A cloth is woven with 90 ends and shots per inch, by a machine with 3 hooks per needle, and 3 shots per card. Find the shots per card if the picks are increased to 135 per inch ?

Ans., 4 and 5 shots per card alternately.

27.—A silk fabric contains 2700 splits, 2 threads in a split, in a width of 30 inches. If the design paper be ruled  $8 \times 6$ , how many picks per inch must the cloth contain to avoid any distortion of the figure ?

Ans., 135.

28.—Assume a figured pattern, to repeat on 288 ends, has to be woven on a machine with a capacity of 304 hooks, which is tied up to 60 ends per inch ; ascertain the number of hooks to be cast out and the reduced set.

Ans., 16 ;  $56\frac{1}{3}$ .

29.—If a design must occupy 76 ends and picks in a 60 set harness, how many ends and picks ought a 40 set harness to occupy to give the same size of pattern, also what relative number of hooks must be cast out in any given machine so as to weave straight in the harness ?

Ans.,  $50\frac{2}{3}$  ; 1 row out of 3.

30.—Suppose that from a 400 machine it is desired to weave a pattern occupying 60 ends, find the number of complete repeats of pattern, and say how many hooks would have to remain idle.

Ans., 6 repeats ; 40 idle.

31.—If a harness is tied up to 72s set, and it is desired to produce a cloth 56s set, how many hooks would have to be cast out in a 400 machine, and how should they be distributed ?

Ans., 88 ; 1 out of 5 and 1 out of 6 alternately.

32.—How many pattern cards would be required to weave a damask cloth 72 inches long, 90 shots per inch, the weft being inserted 2 and 3 shots per card alternately ; the cross border repeat being 18 inches long and centre repeats 9 inches ?

Ans., cross border set 648 cards, centre 324 cards.

33.—A napkin 28 inches long counting 100 shots per inch, is woven by a set of 1200 pattern cards ; find the shots per card.

Ans., 2, 2 and 3.



34.—A 90" damask cloth is woven by a set of pattern cards with 2 picks per card; it is required to weave a similar cloth by the same cards, 108" long. How many picks per card will be necessary?

Ans., 2, 2, 3, 2, 3.

35.—In a Jacquard machine drive, the throw of the crank is 7", length of head lever from connecting rod to fulcrum 28", length of head lever from fulcrum to link 16". Find the lift of the machine.

Ans., 4".

36.—The average lift of the head in single and double-acting and twilling Jacquards is  $4\frac{1}{4}"$ ,  $3\frac{1}{2}"$  and  $3\frac{1}{4}"$  respectively. If A equals 3 units of length of head lever on the Jacquard side of the fulcrum and B equals 4 units of length on the side linked with the reciprocating rod, for single and double-acting Jacquards, what length of throw should be given to the crank lever and double eccentric respectively?

If the stud E in eccentric c in Fig. 156, is set out of centre  $2\frac{3}{4}"$ , what ratio value of compound levers will give the required average lift to the head?

Ans.,  $5\frac{2}{3}"$ ;  $4\frac{2}{3}"$ ;  $4\frac{1}{3}"$ ;  $\frac{2}{13}$ .



## PART IV.

### DESIGNING, CARD STAMPING, REPEATING AND LACING.

---

#### CHAPTER XX.

##### Design Preparation and Card Stamping.

THE machinery and mounting being completely understood for weaving every variety of figured fabric, it remains to consider how the designs are prepared and made ready for reproduction in the loom. The processes involved include sketching, designing or drafting, and transferring the design on to the pattern cards.

**Sketching or  
Drawing.** This is the first and most important factor in the designing process, and involves originality combined with natural or acquired artistic ability. A knowledge of drawing and the ability to draw are first essentials, since no person can design without the ability to draw or sketch well, combined with a knowledge of the variety and forms of flowers in every stage of growth, together with their habits and dispositions. The origin, development and specific characteristics of art in different countries must also be studied, and to all the foregoing must be added common sense, combined with a sound judgment of the fitness of each subject for the different type of fabric intended to be woven.

The variety of textile fabrics for which designs are prepared comprises *simple warp* and *weft figures*, for such cloths as napkins, damasks and dress goods, and more *complex weave structures*, involving two or more coloured wefts to one warp; or two or more cloths woven

together and interchanging in form or colour to suit any desired effect of pattern, for such fabrics as tapestries, quilts, upholsterings, carpets and compound figured structures of every description. The finished sketches are first submitted to the manufacturer or buyer for selection, when particulars are given for drafting.

A detailed description of all the fundamental principles of figure design as applied to woven fabrics is given in *Carpet Manufacture* pages 17 to 47, and a few of the chief compound weave structures as applied to the development of complex figured woven fabrics on pages 280 to 289, for which reason, only a passing note is required in this companion volume.

**Transferring  
the Design to  
Point Paper.**

This process is frequently designated 'drafting'. The operation involves a considerable amount of technical knowledge before the sketch is fully painted on the ruled paper to suit the capacity of the Jacquard machine, the tie of the harness, the fineness of the cloth, and to give practical effect to complex designs. The mere painting or transferring of the sketch to point paper, which is intended to simplify the transference of the design to the pattern cards, is simple enough.

Each set of horizontal and longitudinal squares, on the point paper, corresponds respectively to one pick and one end in the subsequent woven cloth. The markings on these squares, usually represent the warp *raised*, but this is a detail which varies to suit the circumstances. The marks or blanks on each horizontal line of point paper are indicated on the pattern card by perforations or 'misses.' Except for special and complex fabrics, each horizontal line on the paper represents *one* pattern card and each pattern card consequently represents *one* pick in the cloth.

**Card Stamping or Cutting.**

When a painted design is ready for transference to the Jacquard pattern cards, instructions are written on the painted point paper for the guidance of the card cutter in reference to which marks have to be 'cut' or left blank on the Jacquard card.

There are several machines on the market for punching holes in the Jacquard cards according to the required pattern. The 'piano' card stamper is the one most generally adopted. It may be worked by foot or belt driven.

The hand selection of punches and filling of the 'book plates' combined with the railway press is at present largely discarded.

The 'plate' principle with *vertical* press is now chiefly used in carpet manufacture, where the pitch of the holes in the card cylinder is much larger than for ordinary Jacquard machines, see pages 146-150, *Carpet Manufacture*.

The principle of stamping the cards is the same for all machines.

#### The Piano Card Stamper.

The various essential parts of this machine are illustrated at Figs. 326 to 333 inclusive. Fig. 326 is a plan of the cross head or punch box, punches and card carriage; Fig. 327 is a sectional elevation—front view—of the same details and Fig. 328 a side elevation of the chief mechanical parts. The remaining illustrations refer to specific details only. Similar letters in each diagram refer to corresponding parts.

A is the fixed table plate of the machine; B, B, two spindle shafts which pass freely through A; the shafts B B are combined by a cross bar C to which they are adjustably fixed by lock nuts as shown. D, the punch box is fixed to, and supported by the spindles B B, in sympathy with which it is free to move in a vertical plane. Suspended inside the punch box are twelve small steel punches, a, b, 1, 2, 3, 4, 5, 6, 7, 8, c, d, and one large steel punch e, the lower ends of which pass freely through perforations in a fixed plate E which is in two distinct parts—E<sup>1</sup> being the lower, and an exact duplicate of E, except that a portion F is planed away to admit of space for the free insertion of a twelve row pattern card, underneath the steel punches at will.

Finger keys 1<sup>1</sup>, 2<sup>1</sup>, 3<sup>1</sup>, 4<sup>1</sup>, 5<sup>1</sup>, 6<sup>1</sup>, 7<sup>1</sup>, 8<sup>1</sup>, are inserted into the punch box D at the back, and a<sup>1</sup>, b<sup>1</sup>, c<sup>1</sup>, d<sup>1</sup> and e<sup>1</sup>, at the front, all of which are at right angles to the punches, but immediately above

them. Each key is circumscribed, near its centre, by a spiral spring, enclosed within the punch box, as shown. These springs operate to keep the keys normally clear of the heads of the punches.  $F^1$  shows the card race in front of space  $F$ , and level with the perforated plate  $E^1$ .  $G, G^1$  are brackets which can be adjusted to suit

Fig. 327

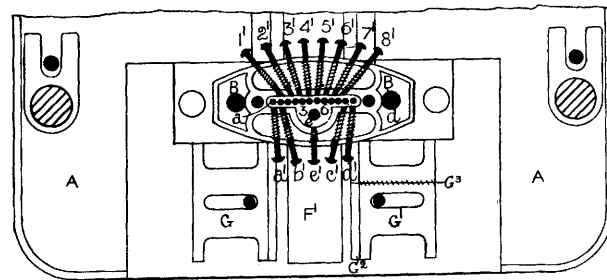
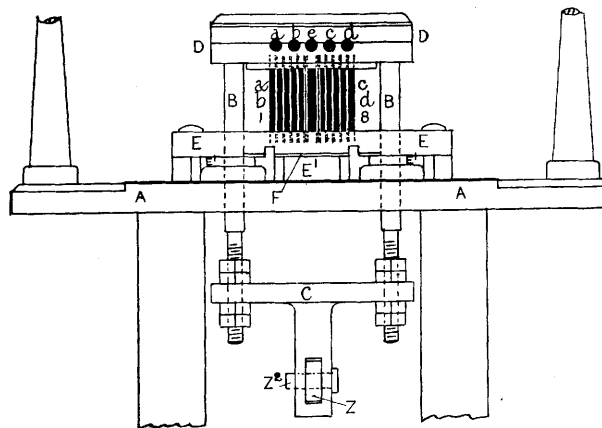


Fig. 326

any width of pattern card within the limits of the machine.  $G^2$  is a supplementary guide plate, sensitively kept in contact with the pattern cards by the pressure of the small spiral spring  $G^3$ , which serves to steady the traverse of the pattern card during the subsequent operation of stamping.

The pattern cards are placed on the race  $F^1$  and passed through the space  $F$ , between the fixed plates  $E, E^1$ , to the nip  $H^1$  of the card carriage  $H$ , (Fig. 328) which rests freely and is free to slide laterally on two steel rails  $I, I$ . A steel plate, containing short projecting steel pins  $J$ , is fixed to the left side of the card carriage  $H$ . The distance between the pins corresponds to the pitch of the holes in the Jacquard cylinder, for which the pattern cards have subsequently to be stamped.  $K$  is an iron bar, shaped to form a spring, one end of which is bolted fast to the table  $A$ , and the other is bent upwards as shown. Secured to this iron spring is a small iron casting  $L$ , containing one fixed and one movable steel "finger" blade,  $L^1$  and  $L^2$  respectively; the latter is fixed to the end of a small spindle  $L^3$  supported and free to move in the casting  $L$  as shown. A spiral spring  $L^4$  circumscribes the spindle  $L^3$  and is contained between the shoulder of the iron casting  $L$  on the left side, and a pin  $L^5$ , through spindle  $L^3$ , on the right. The energy of the spiral spring  $L^4$  is exercised to press the spindle  $L^3$  with its movable finger  $L^2$ , outwards to the right whenever no opposite force is pressing on the finger. An enlarged elevation of this small but important detail is shown separately at Fig. 329, a transverse sectional elevation at Fig. 330, and a plan at Fig. 331.

Normally the fingers  $L^1$  and  $L^2$  rest between the pins  $J$  in the card carriage  $H$ , from the end of which a weight  $M$  is suspended by a string which passes over a small pulley at the end of the machine as shown, the object of the weight being to draw forward the card carriage whenever it is released from contact with the fingers  $L^1$  and  $L^2$ . Fixed in the card carriage  $H$  are two brackets with pivot studs  $N$  and  $O$ . Upon stud  $N$  a simple lever  $N^1$  is pivoted, the right arm of which is bent at a right angle to form the nip  $H^1$  and the left arm normally rests on a spiral spring  $P$ . Fulcrumed at  $O$ , is an inclined lever  $O^1$ , which is normally at rest upon the left arm of the lever  $N^1$ . The energy of the spiral spring  $P$  is exercised to lift the left arm of lever  $N^1$ , and so cause the right arm to nip close to the plate  $H^1$ , but pressure applied to the free arm of lever  $O^1$  overcomes this resistance, and turns lever  $N^1$  counterclockwise, thus making an opening at  $H^1$  which permits the insertion of the pattern card.

Fig. 328

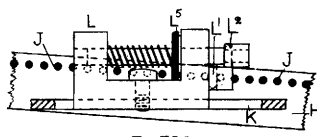
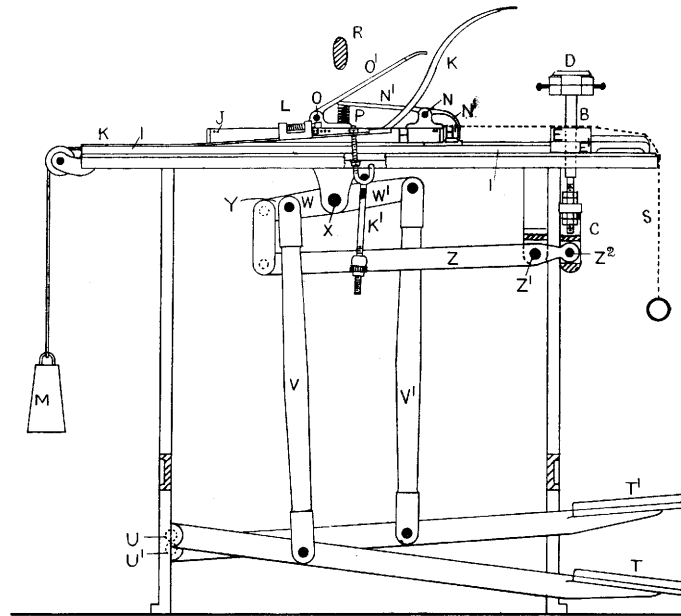


Fig. 329.

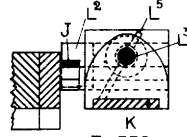
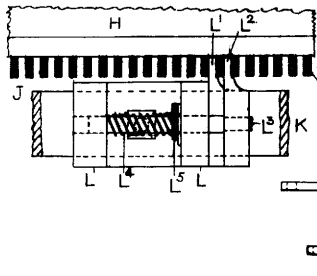
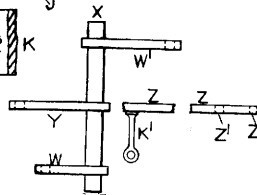


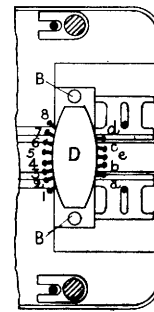
Fig. 330



Figs. 331



332



333

By pressing down the free end of the lever  $\kappa$  by hand, or subsequently through its connections with the treadle levers, the bracket  $L$  with both finger projections  $L^1$  and  $L^2$ , is pressed below and absolutely *clear* of the projecting steel pins  $J$  in the carriage  $H$  which is then free to travel outwards to the left.  $R$  is a fixed iron buffer to prevent the card carriage from running too far back, and  $s$  is a string attached to the carriage which facilitates its being pulled up at will, to the starting or other point.

**Mechanism for  
Reciprocating  
the Punch Box  
and Punches.**

Reverting to Fig. 328,  $\tau$   $\tau^1$  are the left and right treadles pivoted at  $u$  and  $u^1$  respectively. A connecting link  $v$  joins the treadle  $\tau$  to the lever  $w$ , and  $v^1$  similarly connects  $\tau^1$  with lever  $w^1$  both of which levers are on the common fulcrum  $x$ . A third lever  $y$ , pivoted on the same fulcrum  $x$  and compounded with the levers  $w$  and  $w^1$  is linked as shown to a long lever  $z$  pivoted at  $z^1$  and terminally connected through the stud  $z^2$  to the cross rail  $c$  and through it to the reciprocating punch box  $D$ . A plan of the parts  $w$   $x$   $y$   $z$  is separately shown at Fig. 332 and a block plan of the punch box at Fig. 333.

**Combined  
Action of the  
Mechanism.**

The card, upon which the pattern is to be cut, is passed over the race  $F^1$  to the opening  $F$ . The treadle  $\tau$  is then depressed and it in turn depresses the levers  $w$  and  $y$  which move the lever  $z$  in sympathy and counter clockwise about its pivot  $z^1$ , so that the cross rail  $c$ , spindle  $B$ , and punch box  $D$  with the punches, rise until they are sufficiently high to permit the insertion of the pattern card, through the opening  $F$ , between the plates  $E$  and  $E^1$  and into the nip  $H^1$  of carriage  $H$  which is then pulled by the string  $s$  into its starting position close to the punch box  $D$ .

Next the finger keys are selected and pressed over the heads of the punches; simultaneously the right treadle  $\tau^1$  is depressed, the result of which, through link  $v^1$ , turns the levers  $w^1$  and  $y$ , clockwise about the stud  $x$ , and also oscillates in sympathy and direction, the lever  $z$  about the pivot  $z^1$  so that the stud  $z^2$  descends and pulls, with considerable energy, the punch box  $D$  with its punches, down-



wards. All the *free* punches rest upon the surface of the pattern card and rise as the punch box descends.

On the contrary, the punches covered by the finger keys descend and overcoming the resistance of the pattern card, punch holes in it, equal in diameter to the punches and the holes in the plate  $E$  and  $E^1$ .

The actual force applied to the card at the punches is  $x$  times the load applied by the foot to the treadle lever  $\tau^1$  multiplied by the product of the compound levers  $\tau^1, w^1, w, y, z$ .

If  $a$  = the distance  $\tau^1, u^1$ ;  $b = u^1, v^1$ ;  $c = w^1, x$ ;  $d = y, x$ ;  $e = y, z^1$ ;  $f = z^1, z^2$  and  $x$  = the force applied in lbs. by the foot to the treadle lever  $\tau^1$ . Then resultant force applied to the cards at

$$\text{the punches} = x \frac{a}{b} \times \frac{c}{d} \times \frac{e}{f}$$

The illustration Fig. 327 is drawn to scale, hence the student can ascertain the necessary data to solve the problem.

The successive movements of the card carriage for *each tread* are accomplished as follows;—With each ascent of the punch box  $D$  and descent of lever  $z$ , the link  $\kappa^1$  is depressed together with the iron spring  $\kappa$  and the bracket  $L$  until the fingers  $L^1$  and  $L^2$  are clearly below the steel pins  $J$  in the card carriage  $H$ . This allows the spring  $L^4$  to press outwards the spindle  $L^3$  with its finger  $L^2$ , but immediately the pressure is released from the treadle  $\tau$  and the foregoing reversed, the iron spring  $\kappa$  responds to its elasticity and rises with the finger pin  $L^2$  up between the next pair of pins  $J$ . The weight  $M$  and carriage  $H$  then pull the finger  $L^2$  directly over that of  $L^1$ , in which position it remains until the next row of holes in the card has been stamped. This sequence of operations is repeated until this and all the cards have been stamped.

## CHAPTER XXI.

### Card Repeating.

It frequently happens that several sets of punched cards are required from the same pattern for different looms and also in some cases, many of the 'ground' cards are exactly alike. In all such cases it is desirable to reproduce the original set (punched on the piano machine) by the aid of a card repeating machine.

Broken cards have also to be copied and replaced, but since they are usually few in number, they are either re-cut on the 'piano' or reproduced by the aid of a hand 'carrier plate' worked in conjunction with the railway or vertical press for punching cards.

There are two chief types of card repeaters viz. :—the 'Table repeater' which is worked in conjunction with the railway or vertical press—and the 'Automatic card repeater' which both selects the punches and stamps the cards at the rate of about 22 cards per minute.

NOTE.—Before duplicate sets of cards are made, the blank pattern cards are all punched with a Peg and Lace hole cutter and then laced on an automatic card lacer.

#### **Automatic Card Repeaters.**

There are several very good machines, now on the market, designed for the repeating of cards, the chief of which are McMurdo's, of Manchester, and Schroers, of Crefeld. The fundamental principles in each are identical.

Fig. 334 shows a sectional elevation of one row of punches and Jacquard uprights with needles which control the action of the punches and briefly the essential details.

The ordinary Jacquard needles are shown at 1, opposite which is the card cylinder containing the original set of cut cards to be

CARD REPEATING.  
Fig. 334.

325

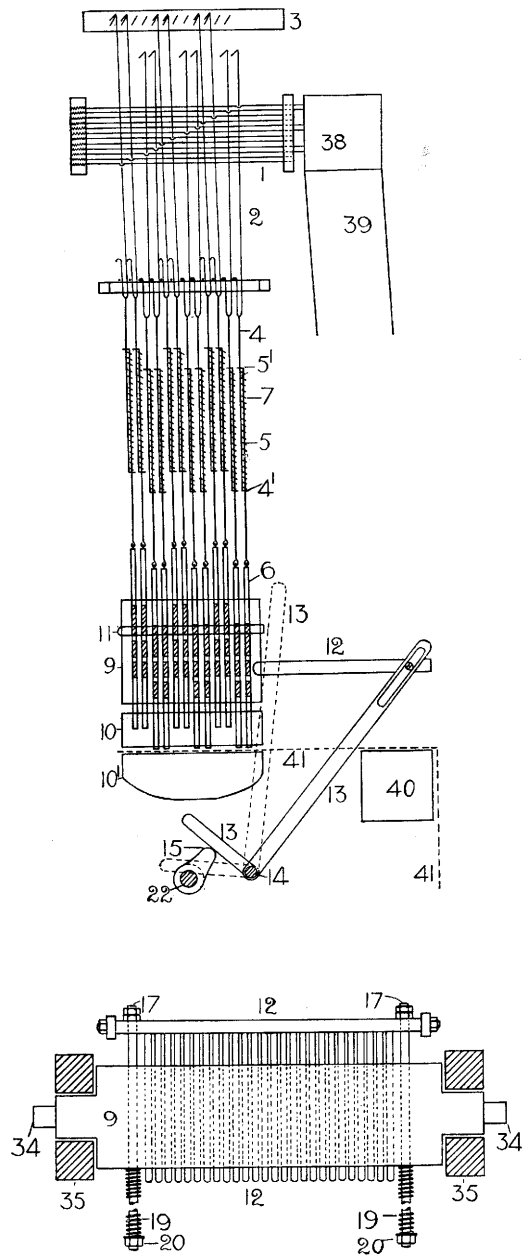


Fig. 336

Fig. 335

duplicated. The upright hooks are shown at 2 and the griffe blades at 3. It will be observed that the hooks are normally *clear* of the griffe blades, hence a blank in the card is equal to a lift of the corresponding upright. 4 and 5 are two pieces of steel wire which combine to link the hooks to the punches 6. The bottom of wire 4 is returned so as to form a loop  $4^1$  through which the wire 5 is passed, the top of wire 5 again being similarly looped at  $5^1$  and through this loop the wire 4 is passed. A spiral spring 7 is placed on the wire 5 and contained between the loops  $4^1$  and  $5^1$ .

The punches 6, of which there are 612, equal to the full capacity of a 600/12 row Jacquard machine, are suspended through perforations in a strong iron box 9 designated the punch box. The perforations in this box are equidistant and coincident with the pitch of the required pattern cards. The box is free to move in a vertical plane, with or without the punches 6.

A second iron 'box' or plate 10, rigidly fixed to the machine gables is likewise perforated, the holes being directly under and in the same plane as those in box 9.

A third iron box  $10^1$ , likewise perforated, is compounded at each end with the underside of box 10, a space being left, except at the ends, between the two 'boxes' 10 and  $10^1$  sufficient to permit the free traverse of the blank cards, which require to be punched. These are first placed and adjusted by hand in the space, after which they are automatically and intermittingly carried forward.

The punches 6, two of which are shown drawn to a larger scale at Fig. 335, constitute one of the special features in the mechanism (see also Fig. 337). Each punch is recessed or cut away to form a 'half round' in three places  $a b c$ .  $a$  is  $1\frac{3}{4}$  inches and  $b$  and  $c$  each  $\frac{3}{4}$  inch in length. In a 612 machine there are 51 rows and the punches are so placed that the *flat* sides of the half rounds, in every two rows are directly opposite each other. This arrangement permits the insertion of a fixed steel comb 11 through the slots  $a$  to prevent the punches rotating about their centres, and a second movable comb 12 containing twenty-six teeth, each of which fits into the slots of either  $b$  or  $c$  in the two rows of punches. The teeth

of this comb can however only enter into the slotted part *c* when this part of any given punch has been raised by the Jacquard to the normal height of *b*.

One end of the steel comb 12 is swivel linked to the free end of the vertical arm of a bell crank lever 13, pivoted on a stud 14 fixed in the gable of the machine. The short horizontal arm of this lever is kept in surface contact with a cam 15 keyed fast to the shaft 22, which rotates constantly and uniformly when the machine is in operation, see Figs. 334 and 337.

A plan view of the punch box and movable comb 12 is shown at Fig. 336. Two steel rods 17 are shown bolted by lock nuts to the ends of the comb 12, and then passed through holes in the punch box 9 as indicated, and project  $1\frac{1}{2}$  inches through the opposite side plate. A strong, spiral spring 19 is placed on each rod and contained between the nut 20 and the punch box 9. These rods serve to keep all the teeth in this movable comb in a perfectly horizontal plane during its traverse outwards or inwards. The spring 19 serves to keep the short arm of bell crank lever 13 in contact with the rotating cam 15.

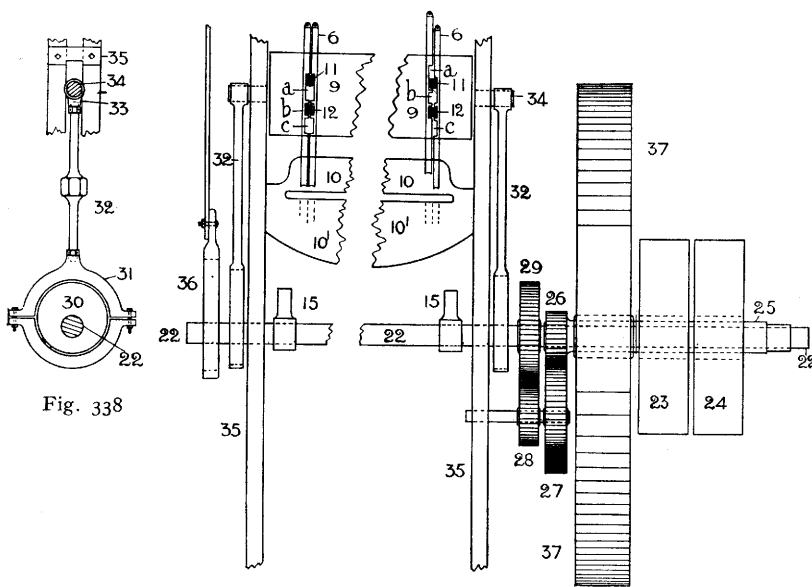
**Reciprocation  
of the  
Punch Box.**

Fig. 337 is a side elevation of the details of mechanism, designed to control the rise and fall of the punch box with punches. 22 is a strong steel shaft supported between the machine gables and having a uniform rotary motion derived by spur gearing combined with the driving pulleys. 23 is a loose pulley and 24 is compounded with a sleeve 25, which is free to rotate on the shaft 22; 26 is a spur pinion containing sixteen teeth, compounded with the sleeve 25. The pinion 26 gears into and drives a stud wheel 27 containing thirty teeth; compounded with wheel 27 is a stud pinion 28 containing sixteen teeth, which gears into and drives a spur pinion 29 containing thirty teeth; this last wheel, 29, is keyed fast to the shaft 22 as is also an eccentric 30, circumscribed by the steel collar 31. An adjustable reciprocating shaft 32 combines this collar with a swivel link 33, which fits loosely on the stud shaft 34, projecting from the end of the punch box 9, which is free to rise and fall between the machine gables 35. The reciprocating rod 32 contains right and left

screw threads by which means the punch box 9 can be most minutely adjusted at any time. Fig. 338 is a detached side view of the eccentric and its connection with the punch box.

From the main driven shaft 22 the Jacquard head is reciprocated by an eccentric 36, and the usual connections. The card cylinder is vibrated through the influence of a "swan neck" lever combined with the Jacquard head. 37 is a balance wheel; 38 the card cylinder, on which the set of cards 39, to be copied is placed; 40 is a feed card cylinder over which the cards 41, to be punched are automatically rotated. (Fig. 334.)

Fig. 337.



**Action of the combined Mechanism.**

The originally cut cards 39 which have to be repeated are placed over the Jacquard cylinder 38 in the usual way. The cards 41 to be stamped as duplicates, which are blank except for the peg and lace holes, are automatically fed, through the agency of the card cylinder 40, between the plates 10 and 10' and under the punches 6.

It will now be evident that if a *fully* perforated card is placed against the Jacquard needles 1 and the machine set in motion, all the uprights 2, will be left clear of the griffe knives and will remain down together with the punches 6 so that the notched portions *b* are in the same plane as the teeth of the comb 12 which now enters into and through the punch box 9 and so locks all the punches 6 which have their ends projecting below the base of the punch plate 10. Simultaneously the eccentric 23, through its connections already described, has moved the punch box 9 into position ready to bring it down with sufficient force as to cause *all* the punches to *pierce holes* in the pattern card—an exact duplicate of the original.

A *blank* original card would press all the hooks 2 over the griffe knives 3, which acting through the mechanism already described, would lift all the punches 6 until the notched parts *c* are in the same plane as the comb 12, which would then enter between the notches and serve to hold *all* the punches 6 *clear* of the space between the punch box 10 and the punch box 10<sup>1</sup>; consequently when the box 9 descends *no holes* are punched in the required duplicate card.

It therefore follows that between a fully and a non-perforated card any selection of punches may be manipulated, and variety of pattern stamped on the cards 41 to coincide with those of the original or parent cards 39.

The two front and back rows of punches may remain out of action to allow the machine to be used for an 8 row card.

## CHAPTER XXII.

### Card Lacing and Lacing Machines.

AFTER stamping the Jacquard cards to suit the pattern, it is necessary to lace them into one continuous string or chain so as to make it possible for them to be rotated over the card cylinder.

Small lots are usually laced by hand but larger quantities are preferably and more economically strung together by a machine.

Fig. 339 shows four cards for an eight row machine as laced by hand. 1 and 2 are the lacing cords and 3 the card.

Fig. 340, the same lacing, minus the cards.

Fig. 341 illustrates the machine style of lacing with ordinary *single* rows for a twelve row machine.

Fig. 342 the same style of lacing, minus the cards.

Fig. 343 for *double* rows of lacing holes.

Fig. 344, the same style of lacing minus the Jacquard card.

In machine laced cards, the cord marked 1 is always on the top of the card and that marked 2 on the underside, except at the lace holes and between the cards, where it is shown locked over cord 1.

### Hand Lacing.

The operation of lacing the pattern cards by hand is usually accomplished on a long and narrow wooden frame, studded with wood pegs, set equidistant and coinciding with the pitch of the peg holes in the card cylinder.

Fig. 345 illustrates a portion of the standard type of card lacing frame; A is the frame, which is suitably supported on wood trestles; B pegs on which the cards to be laced are placed; C the pattern cards; E the lacing cords and F a wire interlocked with the cords E



between two cards. A wire corresponding to F is repeated about every 12 to 20 cards.

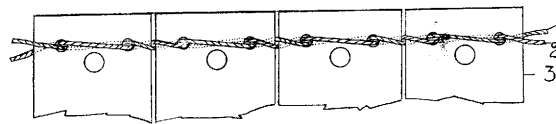


Fig. 339



Fig. 340

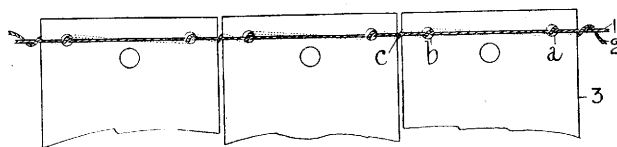


Fig. 341



Fig. 342

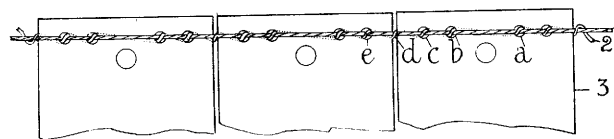


Fig. 343



Fig. 344

### Automatic Card Lacing Machines.

There are two chief types of machines for this purpose in common use :—

- (1) The Rotary Wheel as made by Singer's, of London, and Schroers, of Krefeld.
- (2) The "Rapid," Parkinson's patent.

### The Rotary Wheel Machine.

This machine is made to lace any width of card containing from two to six lines of lacing holes and involving as many heads and shuttles. It is made with from three to six heads and shuttles, each of which is adjustable to suit the different sizes of pattern cards.

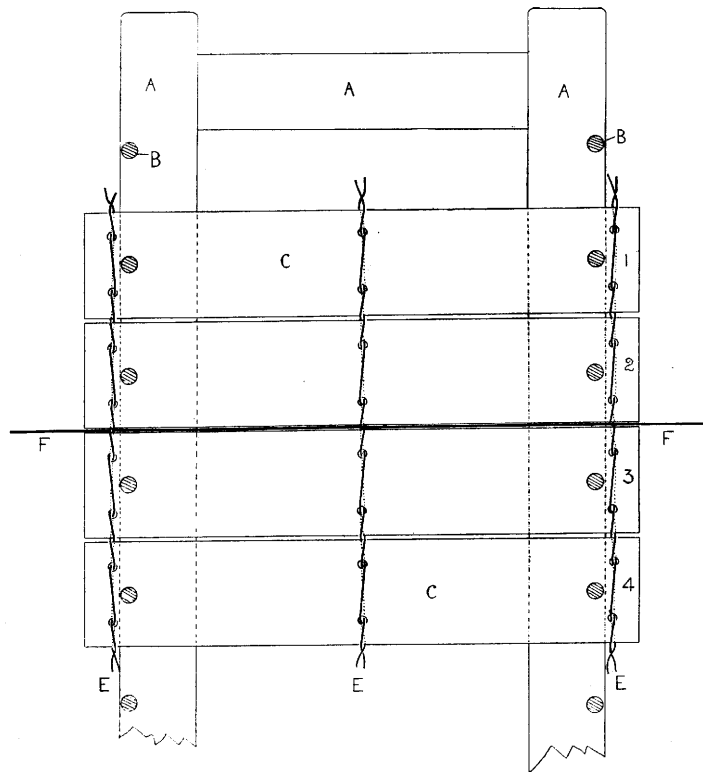


Fig. 345.

The average number of cards laced per minute is twenty-eight. Adjustable feed wheels with carrier pins for holding the cards are used which constitute its chief feature. The shuttle bobbin will hold cord sufficient to lace over 3000 cards for an eight row machine; it is also visible during the whole process of operation which is a distinct advantage since the shuttle can then be changed before all the cord has run off.

**Shuttle  
Vibratory and  
Lock-stitching  
Mechanism.**

Fig. 346 shows in elevation the main features of this principle of lacing including the vibration of the shuttle and the lock stitching mechanism. The pulley driven shaft of the machine from which all the other motions are derived is indicated at 1. Keyed fast to it is a positive tappet 2 in the groove of which an antifriction bowl 3 is free to rotate on stud 4 in lever 5 and also to rise or fall under the controlling influence of the tappet. The lever 5 is keyed fast to shaft 6 and on its remote side is a vertical lever 7 also fastened to the shaft 6. The free end of lever 7 connects, through a swivel link 8 and studs 9 and 10, the shuttle carriage 11, the upper part of which is omitted in the diagram in order to show the shuttle 14. The base 11<sup>1</sup> of the bracket arm compounded with the carriage 11 is circular in section and rests freely and is free to oscillate in the recessed bracket 12 which circumscribes the rotary wheel shaft 20. The shuttle rests freely in the carriage 11 and is oscillated in sympathy with it. The locking cord is shown in the shuttle at 15, the feeding cord in the needle at 16 and the needle itself at 17. The transport wheel 18 contains the projecting pins 19 on which the cards to be laced are placed. This wheel and its duplicates are composed of two detachable halves which are combined and adjustably fixed to the shaft 20. This shaft extends over the full length of the machine being supported and free to rotate between the machine gables. A smooth segment plate 21 is compounded with each transport wheel 18. Against the face of the segment plate the shuttle 14 vibrates; a recess 22 made in the plate 21 permits the free traverse of the feeding needle 17. A portion of the lacing minus the pattern cards is indicated at 23.

**Needle  
Reciprocating  
Mechanism.**

A lever arm 24, fitting loosely on the shaft 6, carries at its free end a stud and antifriction bowl 25, which fits and works freely in the groove of a positive tappet 26 keyed fast to the main shaft 1. A reciprocating rod 27 links stud 25 with the stud 28 which is fixed in the free end of a short lever 29, in turn keyed fast to a shaft 30 which is free to oscillate. This shaft extends the full length of the machine and is supported near the top of it, between the two gables.

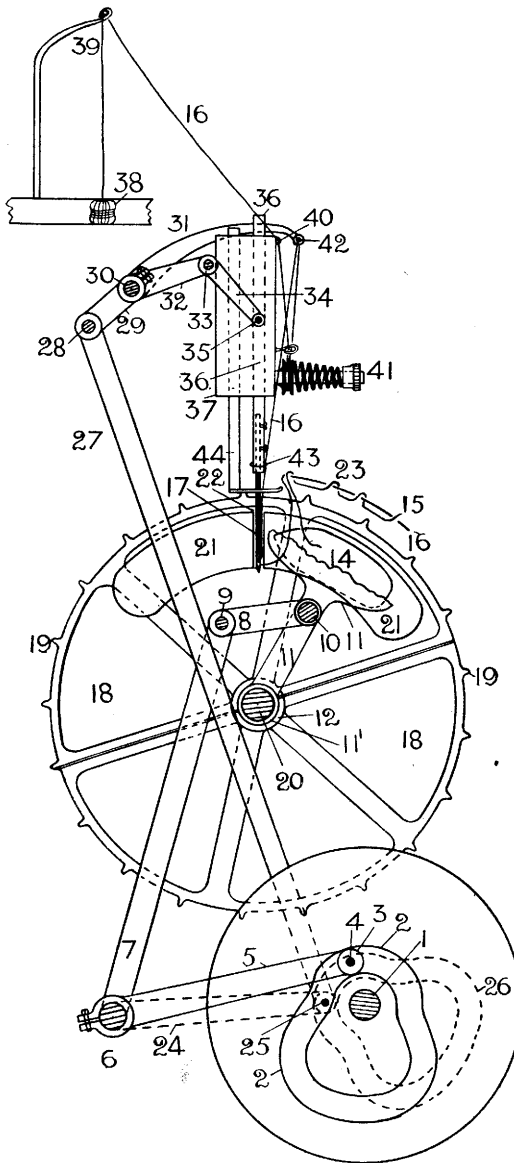


Fig. 346

Fastened to this shaft, for each head, there are two short levers 31 and 32, the former is designed to regulate the feed of the lacing cord 16, and the latter reciprocates the spindle with the needle 17, containing it. The lever 32 carries in its free end, a fixed stud 33, on which fits loosely a swivel link 34, the opposite end of which fits on stud 35 adjustably fixed to the spindle 36 which is supported and free to slide in a vertical plane between two collars of a bracket 37 fixed to the cross head of the machine. The lacing cord 16 passes from the ball 38, over the tension rod 39, through a guide eye 40 and then under the projecting stud 41 with spiral spring and rotary tension washers, as shown. From the stud 41, the cord passes upwards and through the eye 42, in lever 31, then back through the fixed guide eye 43 in the spindle 36 to the needle 17, a guide spindle for which is shown at 44.

**Action of the Mechanism.** With the constant rotation of the pulley driven shaft 1 and the positive cam 2, the bowl 3, stud 4 and lever 5 combine to constantly oscillate the shaft 6 which in turn vibrates the lever 7, stud 9, swivel link 8, stud 10 and shuttle carrier 11 together with the shuttle 14, to and fro for each complete lock stitch required.

Simultaneously actuated from the same initial source, the cam 26 reciprocates through stud and bowl 25 the rod 27, which in turn, through stud 28 and lever 29, oscillates the shaft 30. This shaft correspondingly alternates the lever 32, and through stud 33, swivel link 34 and stud 35, the spindle 36 together with the needle 17 and lacing cord 16.

The supply and regulation of the delivery of this cord is controlled from the same shaft 30 which also alternates the lever 31 in sympathy with lever 32 and spindle 36.

**Mechanism and Rotation of the Feeding Wheels.** The details of the mechanism designed for this purpose are arranged to operate at the opposite and right hand side of the machine. Fig. 347 shows an elevation of these parts. Upon the rotary shaft 1, a positive tappet 46 is keyed, in the groove of which an antifriction bowl 47, carried by a stud 48 is kept

in rolling contact. The stud 48 is fixed in the vertical arm of a balk or double acting lever 49 which is pivoted on the fixed stud 50. The left arm of this lever carries a stud 51 on which a reciprocating rod 52 fits loosely and combines, through the adjustable stud 53, the ratchet lever 54 which fits loosely on the transport or feed wheel shaft 20 upon the end of which a large ratchet wheel 55 is adjusted. A small pawl lever 56 fitting loosely on the stud 57, in the lever arm 54, engages with the ratchet teeth of wheel 55.

Fixed in the right arm of lever 49 is a stud 58 upon which a reciprocating rod 59 is placed; the same links through an adjustable stud 60, a second ratchet lever 61 also fitting loosely on the shaft 20. A pawl lever 62 on stud 63 in lever 61 also engages with the teeth of the ratchet wheel 55. The throw of the arm on the right is greater than on the left, consequently whenever the pawl lever 62 on this lever engages with the teeth of the ratchet wheel 55, the latter is rotated clockwise, a greater distance, than when the ratchet pawl lever 56 operates at the opposite side. A third pawl lever 64, but stationary, is pivoted on the fixed stud 65, above the top of the ratchet wheel 55, the object of which is to prevent the ratchet wheel from slipping backwards.

Two out of every three ratchet teeth on the wheel 55, are only cut half way across the face of it, see part plan Fig. 348. The pitch between the teeth  $a$   $b$   $c$  for a 12 row 600 machine is  $\frac{3}{4}$ ,  $\frac{3}{4}$  and  $1\frac{3}{4}$  inches respectively. The pawl lever 56 engages with the half teeth and rotates the wheel 55 a distance equal to  $a$  or  $b$  while the pawl 62 engages with the full teeth to rotate the ratchet wheel a distance equal to  $c$ . The pitch of these teeth and the size of the wheel are designed to give the correct amount of rotation to the transport wheels 18 so as to bring the lace holes in the cards 23 directly underneath the feeding needle 17 (see also  $a$ ,  $b$ ,  $c$  Fig. 341).

The action of the mechanism is as follows:—With the constant rotation of the pulley driven shaft 1 and the positive tappet 46, the antifriction bowl 47 and stud 48 together with lever 49 are reciprocated about the pivot stud 50 which motion in turn, is generated through stud 51, rod 52 and stud 53 to lever 54 and pawl lever 56

to oscillate the same about the shaft 20, so that with each upward movement of pawl lever 56 the wheel 55 is rotated  $\frac{3}{4}$  of an inch at its periphery.

Fig. 348.

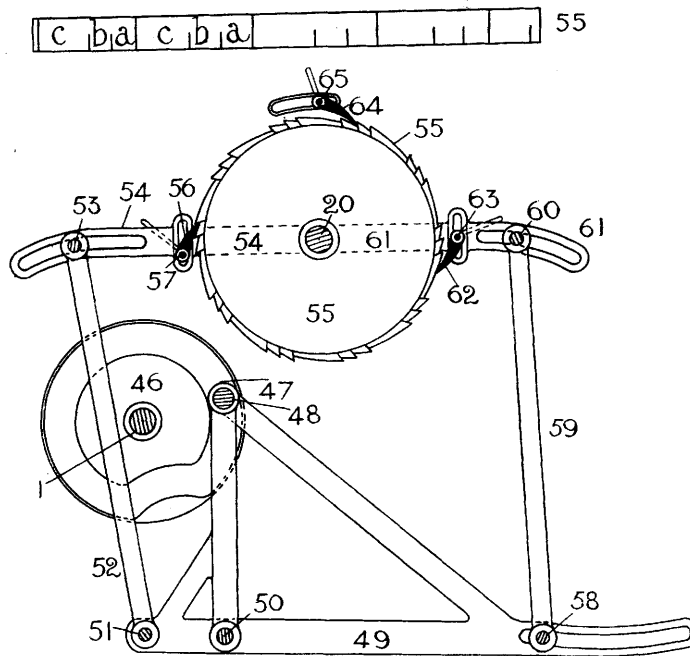


Fig. 347

In a similar manner the details 58 to 62 inclusive, combine to rock the lever 61 and pawl lever 62 so that with each downward throw, this pawl rotates wheel 55, a distance equal to  $1\frac{3}{4}$  inches at its periphery representing  $2\frac{1}{2}$  inches in the length of the stitch.

The ratchet wheel 55 and transport wheels 18 are all interchangeable so that with the adjustment of the connections with the double acting lever 49 any required variation in number of stitches per card and length of stitch can be obtained.

### The "Rapid" Machine.

#### GENERAL PRINCIPLES OF THE MECHANISM.

There are three important parts and motions in this machine, viz:—(a) The chain support and traverse for the cards; (b) the shuttle which contains the locking cord and (c) the needle which feeds the cord.

The intermittent motion of these details is important and full of interest.

Fig. 349 is a sectional elevation to illustrate the chief features of this mechanism and method of lacing.

The feeding or straight cord is shown at 1, and the locking cord at 2; the pattern card is omitted. 4 is the needle, which is free to rise and fall, and carries cord 1 in a vertical plane. 5 is a free shuttle contained in a slide carriage (see 74, Fig. 352), which is free to move in a horizontal plane; this shuttle carries cord 2. 6 is a fixed iron plate against the face of which the shuttle travels; the plate 6 contains a groove 7 into which needle 4 reciprocates without interfering with the shuttle. The plate 6 is fixed to the two shafts 8 and 8', in turn supported by the machine gables 9 and 9' respectively. From each link, in the link chain 10, projects a peg 10' on which the cards to be laced are placed. The chain is supported on the square prism 11 fixed on the shaft 13 which is free to rotate partially and intermittingly between the bracket support 14 and its duplicate on the opposite side of the machine. The pulley 12 fits loosely on a fixed shaft 15 in turn supported by the bracket 16 which is secured to the shaft 8 and gable 9, as shown. A tension pulley 17 is carried in the bracket lever 18 pivoted on the fixed stud 19. A spiral spring 20 combines lever 18 with the fixed bracket 16 and thus keeps the tension pulley exercising a sufficient negative pressure on the chain 10.

There are three important movements to be performed for each complete stitch. The card chain is rotated with the pattern cards into position, *i.e.*, with the lace holes directly under the point of the needle 4 which then descends into the groove 7, the shuttle receding



but immediately returning to complete the lock stitch, whilst the needle remains stationary at the bottom.

Illustrations showing three positions of the shuttle in its relation to the formation of the lock stitch are supplied. (1) In Fig. 349 the shuttle 5 is shown fully back, the needle 4 being at

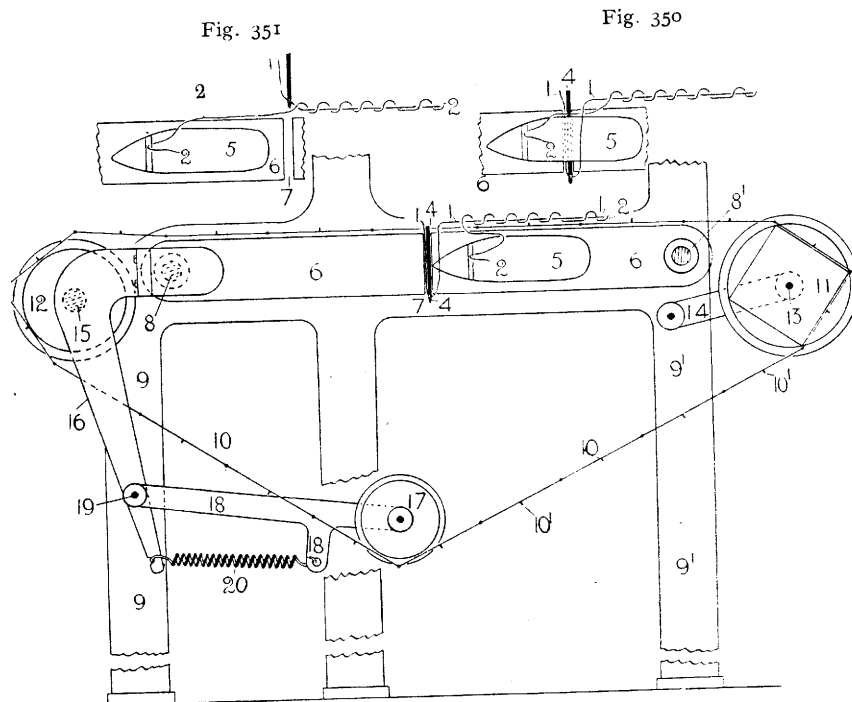


Fig. 349

the bottom with the locking cord in its double form from its eye upwards, one strand of which returns to the store spool and the other to the last hole in the pattern card.

(2) In Fig. 350 the shuttle 5 is shown in the centre of its forward traverse, the needle 4 having risen, but the cord 1 on the *card* or *right* side of the needle eye has gradually bulged outwards so as to permit the shuttle 5, which simultaneously moves forward to the left, to enter behind strand 1 on the right, but to pass

in front of the needle 4 with strand 1, on the left side during which latter period the needle remains stationary.

(3) In Fig. 351 the final and forward position of the shuttle 5, together with its relation to the cords, is shown.

The mechanism and operation of these foregoing motions is shown and described separately as follows :—

**Mechanism and  
Operation of  
the Card Chain.**

Figs. 352 and 353 are sectional elevations as seen from the sides of the machine—the former being on the driving pulley side and the latter on the opposite or right hand side of the machine. 21 is the driving pulley on shaft 22; a spur pinion 23 on this shaft gears into a spur pinion wheel 24 fixed on shaft 25, which is supported and free to rotate between the machine gables. At the opposite side of the machine a *change* spur pinion 26, Fig. 353, gears into a large *change* spur wheel 27 set screwed to a short stud shaft 28 suitably supported to the machine gable. Free to rotate with the stud shaft 28 is a disc plate 29 with which segment wings or tappets *a, b, c, d, e*, of various heights are adjustably compounded; whilst the disc, or one or other of the tappets is kept in rolling contact with an antifriction bowl 30 centred on lever 31 in turn fulcrumed on the stud 32 compounded with the machine gable 9. A loose stud 33 combines the free end of lever 31 with a link 34 which is, in turn, combined by a similar loose stud 35 to a small bell crank lever 36, pivoted loosely on the fixed shaft 37. A loose stud 38 combines the vertical arm of lever 36 with a “pawl” pushing “catch” 39, the edge of which rests freely on the ratchet wheel 40 keyed fast to the shaft 37. The shaft 37 contains the chain driving pulley 11, see Fig. 349, where this shaft is numbered 13. The pitch of the teeth in the ratchet wheel 40 varies to suit the amount of rotation required in the shaft 37 and the traverse of the pattern chain 10. The different heights of the segment wings in tappets *a, b, c, d, e*, are designed for the same object—the longer the tappet wing, the greater the lift in lever 31, which in turn is subsequently transmitted to lever 36 and pawl 39. The continuous rotation of the tappet disc plate 29, by the train 21 to 27 lifts intermittingly the bowl 30 and lever

31 which, in turn, oscillates the bell crank lever 36 and moves the pawl 39 to and fro, which thus engages with the teeth of the ratchet wheel 40 and pushes it forward one tooth at a time and so rotates the chain shaft 37 and chain 10 with the cards intermittingly.

• There are five stitches to be made for each pattern card (Fig. 343); these are shown at *a b c d e*. The distance from *a* to *b* is  $1\frac{5}{16}$  in., and from *b* to *c*, *c* to *d*, *d* to *e*, and *e* to *a*,  $\frac{9}{16}$  in. each. The

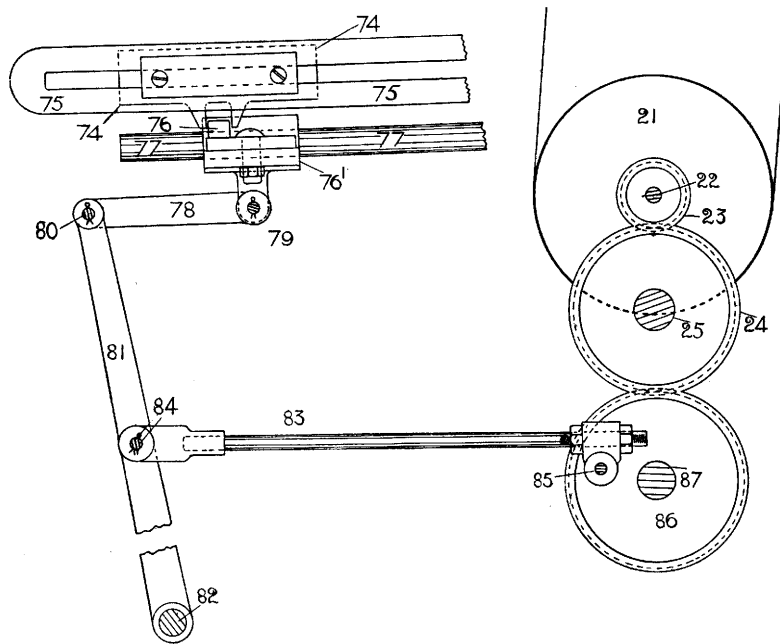


Fig. 352

wings *a b c d e* on the disc tappet plate 29 and the spaces similarly lettered on the ratchet wheel 40, respectively combine to move the pattern chain the required distances mentioned above.

The accessory details 41 to 53 inclusive, serve to brake the wheel 52 combined with the ratchet wheel shaft 37. A five pointed cam 41 is secured, on the remote side of the disc plate 29 to the shaft 28; the tappet 41 is kept in rolling contact with an antifriction roller 42 on stud 43 in lever 44, suspended and pivoted to the fixed

stud 45; the free arm of lever 44 is combined by a spiral spring 46 to a fixed stud 47. A second spiral spring 48 combines the lever 31 through hook 49 also with stud 47. A fixed pin 50 in the sleeve of lever 44 retains one end of a thin but strong steel 'band' 51, which circumscribes the periphery of the brake wheel 52 compounded with the shaft 37; the spring 51 is adjustably terminated and fixed to the lever 44 in the point 53.

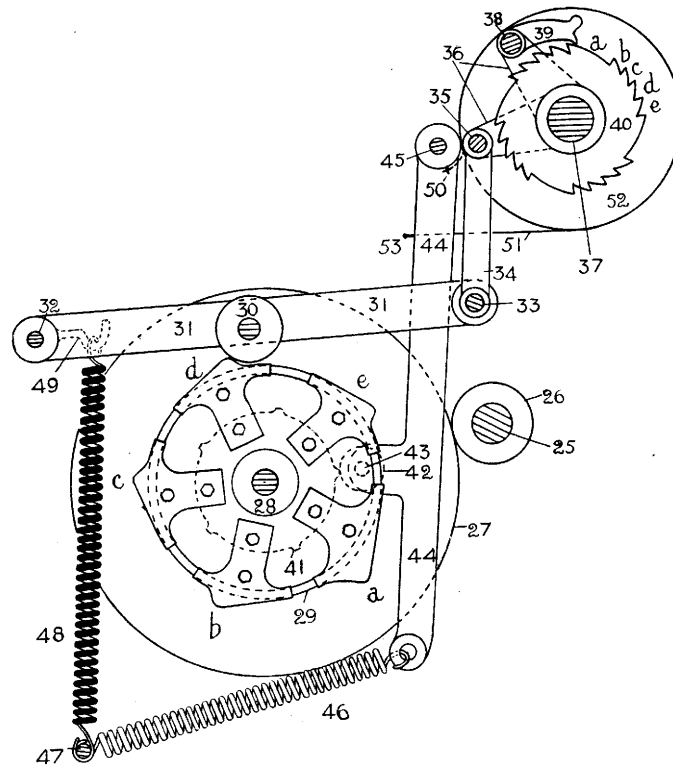


Fig. 353

**Mechanism and  
Action of the  
Feeding Needle.**

The next movement in order is the operation of the feeding needle, the essential details of which are shown in a sectional elevation at Fig. 354.

The feeding needle 4 is adjusted in a spindle 53, which passes freely through the short arms projecting from the fixed

bracket 54, and it is held in position by a reciprocating link 55, which is combined with a stud and collar 56, the latter being set screwed fast to the spindle in the position shown. The link 55

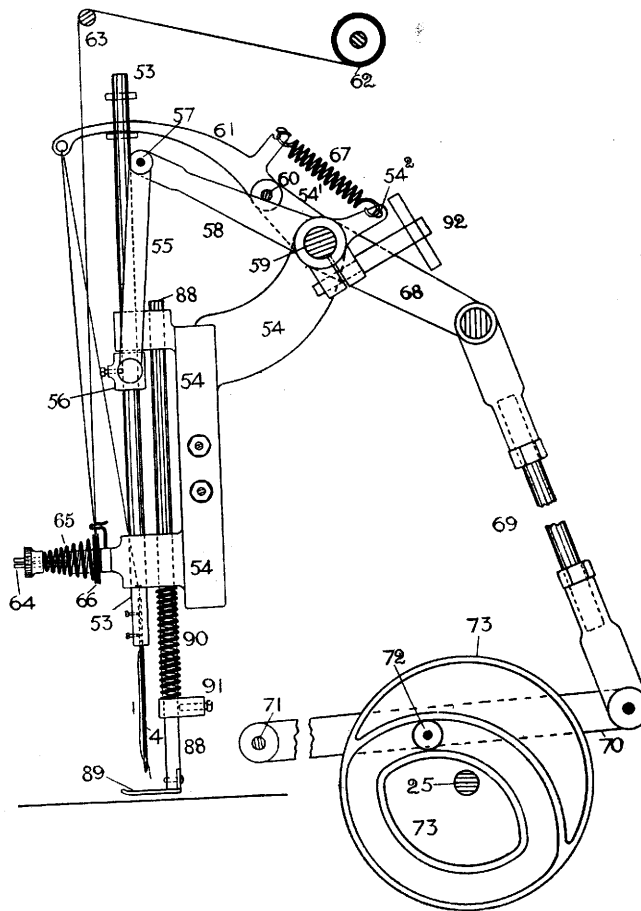


Fig. 354

combines through a loose stud 57 with the simple lever 58 adjusted to the shaft 59 which is supported and free to oscillate in the right arm projecting from bracket 54 and its duplicate at the opposite side of the machine.

54<sup>1</sup> and 54<sup>2</sup> are two fixed wings of the bracket arm 54. A stud 60, fixed in the wing 54<sup>1</sup>, serves as a pivot for a quadrant lever 61, the free arm of which passes through a slot in the spindle 53 which is large enough to permit the free movement of the lever 61 independently of the spindle or vice versa. A hole is perforated near the free end of this lever through which the lacing cord 1 is passed. The cord is taken from the supply spool 62 over the tension bar 63, and sometimes over a second tension bar, then down and under a fixed spindle 64, upon which loose washers are placed at each side of the cord.

An adjustable spring 65 placed also on the spindle combines with the washers 66 to fully tension the cord 1, which next passes upwards through the hole near the end of lever 61, and back downwards through the eye in the feeding needle 4. The quadrant lever 61 is kept normally under tension by the spring 67, which combines the wing on lever 61 to the bracket arm 54<sup>2</sup>.

The oscillating shaft 59 receives its motion through the following connections. 68 is a simple lever keyed fast to the shaft 59. An adjustable reciprocating rod 69 combines the lever 68 with a second lever 70 pivoted on the stud 71 fixed in the machine gable; an anti-friction bowl 72 carried by the lever 70 is kept in rolling contact with the positive tappet 73 keyed fast to the shaft 25. This tappet is constructed to reciprocate through the bowl 72 and lever 70, the rod 69 which, in turn, through lever 68, oscillates the shaft 59 and lever 58 which, through link 55 and collar 56, reciprocates the spindle 53 with the locking needle 4. The motion of the spindle with the needle to the bottom of its journey is continuous, after which it immediately begins the upward journey for a short distance so as to form a loop which admits of the entrance of the tip of the shuttle, after which it dwells until the shuttle has passed through the loop thus formed, see Figs. 349, 350 and 351. Then immediately the shuttle continues the return journey until it reaches the top of its traverse, where it dwells a sufficient length of time to permit the free traverse of the card chain which moves a card forward, ready for the next lock stitch.

When the machine is in action the cord 1 is tight and keeps the free arm of the quadrant lever 61 under tension and clear of the upper shoulder in the groove near the top of the spindle 53, as in Fig. 354. After descending about one inch the spindle begins to pull down the quadrant lever 61 in sympathy until it has reached the bottom of its traverse, tension meanwhile being put upon the spring 67. The spindle 53 dwells at the bottom to allow the shuttle sufficient time to complete its traverse and lock stitch. Immediately the spindle commences to rise clear of the pattern cards, the spiral spring 67 in sympathy, exercises its stored energy to lift the quadrant arm 61 to its highest position and to take up any 'slack' formed in the feeding cord 1.

This sequence of intermittent operations is automatically continued until all the pattern cards have been laced.

**Operation  
of the Shuttle.**

Fig. 352 is a sectional elevation of the details designed for this operation. The shuttle rests freely in a carriage 74 which is supported by the slotted plate 75 and along which it can slide freely. The shuttle carriage and its duplicates are kept in close contact with a straight and longitudinal bar 76 which is compounded with a sleeve 76<sup>1</sup> and its duplicate at the opposite side of the machine. The sleeve 76<sup>1</sup> fits loosely on the fixed shaft 77 along which it is free to reciprocate. A link 78 combines the stud 79, compounded with sleeve 76<sup>1</sup>, with the stud 80 in the simple lever 81 pivoted at 82. A reciprocating link 83 combines lever 81 in the point 84 to the stud 85 which is set out of centre in the spur wheel 86 on the fixed stud 87. The wheel 86 is continuously rotated through its connection with the spur wheel 24 on shaft 25. The continuous rotation of this train of wheels impart through stud 85 and details 74 to 87 inclusive, the requisite varying velocity of movement to the carriage 74 with shuttle 5. The shuttle begins to travel slowly until its tip enters behind the loop formed in the feed cord 1; the needle 4, with cord 1, has simultaneously commenced its return journey, but dwelt a sufficient length of time to permit the free passage of the shuttle, through the loop, after which it travels with increasing velocity to

the centre of its traverse, from which it decreases in the same velocity ratio to the end of its journey.

**Card Irons or Cradles.**

After the pattern cards are cut and laced, it is necessary to 'wire' them which consists of interlacing thin iron wires with the lacing cords between every 12 to 20 cards. The wires should be of sufficient length to project from  $\frac{1}{2}$  to  $\frac{3}{4}$  of an inch beyond the width of the pattern cards, see Fig. 345.

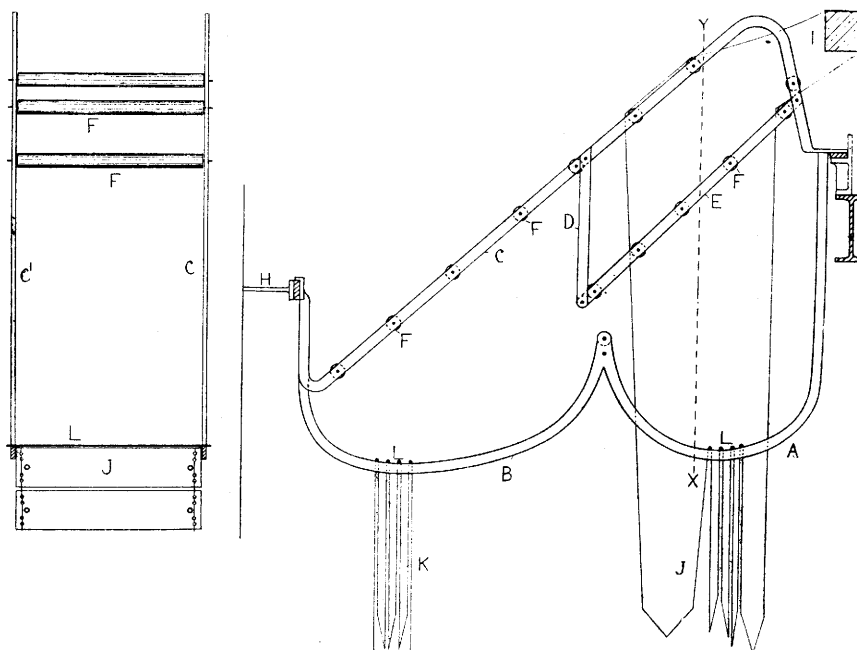


Fig. 355

Fig 356

'Card irons' or a 'card cradle' is an arrangement which consists of two groups of flat irons, fixed at the back of the loom directly underneath the card cylinder. The wired cards are normally supported and suspended between the two series of card irons, which are set apart a sufficient distance to allow the cards to



fall down from, or to be drawn up to the card cylinder, without any obstruction from the card irons.

Figs. 355 and 356 are front and side elevations respectively of the foregoing, the former being a section through  $x y$ .

$A B C D E$ , together with their duplicates at the opposite side of the machine are the card irons; combined with wood rollers  $F$ , the whole of which constitute the card cradle for two sets of cards which may be interchanged at will. The ends of the cradle are adjustably combined with Jacquard gantry  $G$  on the right, and a fixed wall or loom bracket  $H$  on the left, as shown. The position of the card cylinder is indicated at  $I$ , the set of cards at  $J$  and the duplicate set at  $K$ . As the pattern cards  $J$  leave the card cylinder  $I$  they pass over one of the rollers  $F$  in iron  $E$  and fall until the ends of the wires projecting beyond the cards rest upon the irons of the cradle section  $A$  where they are stored and gradually pushed to the back from whence they are drawn up over the rollers  $F$  in the iron  $C$ .

In a similar way the second set of cards  $K$  may be worked from the cradle section  $B$ , as for example when weaving crossborder patterns.



## INDEX.

	Page
Advantages relative—Of extra warp and weft spotting .. ..	224
Automatic card lacing machine—" Rotary " .. ..	332
"  "  "  "  "  "—" Rapid " .. ..	338
"  cross border Jacquard .. ..	123
"  detachment of picking mechanism in swivel loom .. ..	238
"  stop motion for double lift, double cylinder Jacquard .. ..	98
Balance of structure—Gauze and ordinary weave interlacings .. ..	207
Bessbrook, Irish—Twilling Jacquard, mechanism of .. ..	138
"  Scotch—Twilling Jacquard, mechanism of .. ..	142
Bouchon's draw loom .. ..	61
Card cylinder—Automatically reversing .. ..	128
"  "  — Bessbrook, mechanism of .. ..	138
"  "  — Bradford motion with escapement apparatus .. ..	91
"  "  — Driving two .. ..	96
"  "  — Principle of the swing lever .. ..	75
"  "  — Rotating .. ..	75
"  "  — Rotating on slide principle with " Swan Neck " .. ..	78
"  "  — Rotating on spindle slide and bell crank principle .. ..	79
"  "  — Swivel slide, double cylinder motion .. ..	98
Cards—Use of, for different widths and fineness of cloth .. ..	150
Card irons or cradles .. ..	346
Card lacing .. ..	330
"  "  — By hand .. ..	330
"  "  — Automatic .. ..	331
"  "  Machine—" Rotary Wheel " .. ..	332
"  "  "  "—" Rapid " .. ..	338

INDEX.

	349
	Page
Card repeating .. .. .	324
„ repeaters—Automatic .. .. .	324
Cards—Saving of in Verdol Jacquard .. .. .	245
„ Shots per—For twilling Jacquard .. .. .	308
Card stamper—The piano .. .. .	318
„ „ —Mechanism of the punch box and punches .. .. .	322
„ stamping or cutting .. .. .	317
„ wiring .. .. .	346
Carver's combined 5 and 8 leaf twilling Jacquard .. .. .	145
Casting out .. .. .	306
Centre shed Jacquard .. .. .	255
Comberboard—Styles of perforation .. .. .	273
Counterpoise principles—Applied to Jacquards .. .. .	161
„ —Dead weight with compound levers .. .. .	161
„ —Problems on value of.. .. .	167
„ —Solid drawing rods and spiral springs .. .. .	165
„ —Spiral spring with single lever .. .. .	162
„ —Cross's counterpoise harness .. .. .	56
Crossley's or Mc.Murdo's cross border mechanism .. .. .	120
Defects and advantages of twilling Jacquards .. .. .	156
„ of split harness .. .. .	188
Design preparation .. .. .	316
„ —Transferring to point paper .. .. .	202 and 317
„ —Three leaf, plan and details .. .. .	22
Diaper patterns—Old .. .. .	40
Draçup's open shed .. .. .	103
Draw loom—Bouchon's .. .. .	61
„ „ —British efforts to supersede .. .. .	54
„ „ —Cross's counterpoise harness .. .. .	56
„ „ —“ Comb ” .. .. .	56
„ „ —Details of .. .. .	46
„ „ —Falcon's .. .. .	62
„ „ —French efforts to supersede .. .. .	61
„ „ —Lashing the pattern, principle of .. .. .	49
„ „ —Mechanical aids for draw boy .. .. .	49
„ „ —Mechanical draw boy .. .. .	51
„ „ —Patent specifications .. .. .	45
„ „ —Taylor's double necks .. .. .	60
„ „ —Vaucanson's epoch-making changes .. .. .	63
Driving Jacquards—Varieties of .. .. .	107
„ „ —Cam .. .. .	107

	Page
Driving Jacquards—Chain .. .. .	109
"      "   —Compound .. .. .	110
"      "   —Bradbury's direct lever counterpoise .. .. .	114
"      "   —Gauze Jacquard and easing mechanism .. .. .	200
"      "   —Pressure harness, intermittent .. .. .	177
"      "   —Pressure harness single lift .. .. .	177
"      "   —Pressure harness double lift .. .. .	178
"      "   —Compound oscillating pulley .. .. .	110
"      "   —Two lever principle .. .. .	111
Driving Twilling Jacquards—Compound .. .. .	160
"      "      "   —With dead weight counterpoise .. .. .	161
"      "      "   —With solid drawing rods and spiral springs .. .. .	165
"      "      "   —Single lever with spiral spring counterpoise .. .. .	162
"      "      "   —Problems on compound driving and value of counterpoise .. .. .	167
Easing motion auxiliary—For gauze .. .. .	198
"      "      "   mechanism—Action of .. .. .	200
Exercises—In harness mounting .. .. .	310
Falcon's draw loom .. .. .	62
Gauze or Leno Jacquards .. .. .	191
"   —Action of easing motion mechanism .. .. .	200
"   —Combinations with ordinary weave interlacings, and relative balance of structure .. .. .	207
"   —Drafting and douping .. .. .	194, 204
"   —Driving the Jacquard and easing mechanism .. .. .	200
"   —Easing motion auxiliary .. .. .	198
"   —Figuring with one doup and ordinary Jacquard machine .. .. .	204
"   —Nomenclature of mounting .. .. .	191
"   —Transferring design to point paper .. .. .	202
"   Reed—Action of tug reed mechanism .. .. .	220
"      "   —Combination with easing rod .. .. .	218
"      "   —Constructional details .. .. .	219
"      "   —Mechanism, details of .. .. .	214
"      "   —Object of .. .. .	211
"      "   —Reciprocating mechanism of tug reed .. .. .	219
"      "   —The Anderston foundry .. .. .	214-222
Hand loom weaving—Treadle shedding .. .. .	32
"      "   —Different patterns produced by varying the treading .. .. .	36

	Page
Hand loom weaving—Factors in pattern production .. ..	38
"    "    —Treadle mounting, details .. ..	33-35
"    "    —Treadle and twilling mechanism, combined ..	40
Harness building—Sequence of processes in .. ..	259
"    mounting—Apparent increase in the normal figuring capacity ..	282
"    "    —Classification of ties .. ..	274
"    "    (1) Border pattern formed from repeating centre	294
"    "    (2) Centre, point or turn over tie .. ..	276
"    "    (3) Complex ties .. ..	277
"    "    (4) Cross border tie with part single in centre	278
"    "    (5) Damask tie with point and single centre ..	282
"    "    (6) Damask tie with repeating centre ..	278
"    "    (7) Double point tie .. ..	292
"    "    (8) Inversion and repeat of point tie in border ..	287
"    "    (9) Part repeat of single in border .. ..	284
"    "    (10) Point tie in border with repeating centre ..	291
"    "    (11) Re-arranged single in border .. ..	284
"    "    —Exercises with answers .. ..	310
"    "    —Levelling the harness 'below the board' .. ..	265
"    "    —Levelling the harness 'above the board' .. ..	266
"    "    —Mechanism for varying the width of the harness ..	296
"    "    —Making the upper and lower couplings .. ..	262
"    "    —Marking off the comberboard .. ..	274
"    "    —Principles and routine of .. ..	259
"    "    —Principles of .. ..	269
"    "    —Problems and worked examples .. ..	303
"    "    systems .. ..	269
"    "    "    —(1) The London or French .. ..	272
"    "    "    —(2) The Norwich .. ..	270
"    "    —Tugging operations .. ..	263
"    "    —Tying up the harness to serve for two widths of cloth	295
"    "    —Warping the harness twines .. ..	263
"    "    —Tying above and below the board : a comparison ..	261
"    reeds .. ..	273
"    tying—Knots employed .. ..	259
"    —Varying the set of the .. ..	305
"    and shaft mounting—The original compound .. ..	54
Heck—Adjustable .. ..	301
"    —Mechanism of .. ..	299
"    —Necessity for and use of .. ..	299
"    —Problems .. ..	301
Herringbone—Four leaf, plan and details .. ..	22

	Page
Honeycomb weave—Plan and details .. .. .	24
Huck, "Common"—Plan and details .. .. .	23
„ "Devon"—Plan and details .. .. .	23
Index, Verdol or Schroer's Jacquard .. .. .	245
Jacquard, Joseph Marie .. .. .	64
Jacquard machine—Modern mechanism .. .. .	67
„ „ —Brussels and Wilton carpet .. .. .	258
„ „ —Centre shed .. .. .	255
„ „ —Double cloth or Ingrain carpet .. .. .	258
„ „ —Automatic cross border .. .. .	123
„ „ —Carpet cross border .. .. .	123
„ „ —Cross border mechanisms .. .. .	117
„ „ „ „ —Crossley's .. .. .	120
„ „ „ „ —Devoqe's .. .. .	118
„ „ „ „ —Rothwell's automatic .. .. .	123
„ „ —Needles and special uprights .. .. .	128
„ „ —Double lift .. .. .	84
„ „ —Double lift, driving the head levers, ordinary method .. .. .	87
„ „ —Double acting, double cylinder .. .. .	95
„ „ double lift—Single cylinder, details .. .. .	85
„ „ „ —Single cylinder, independent drive for .. .. .	89
„ „ —Figuring capacity of .. .. .	82
„ „ —Leno or gauze .. .. .	192
„ „ —The Verdol or Index .. .. .	245
„ „ the Verdol—Action of the cards and mechanism .. .. .	250
„ „ „ —Details of mechanism and driving the needle plates .. .. .	251
„ „ „ —Mechanism and driving of the Jacquard head .. .. .	254
„ „ —Open shed, Dracup's .. .. .	103
Jacquards—Problems on uniform depth of shed with two or more machines .. .. .	112
„ single lift .. .. .	67
„ „ —Action of the combined parts .. .. .	74
„ „ —Details .. .. .	68
„ „ —Reciprocation of head lever .. .. .	74
„ „ —Timing the various movements .. .. .	80
„ springless—Hardaker's .. .. .	104
„ „ —Wadsworth's .. .. .	105
„ twilling .. .. .	131
„ „ —Advantages and defects of twilling motion .. .. .	156

INDEX.

	353
	Page
Jacquards twilling, Bessbrook or Irish .. .. .	132
"    "    "    —Arrangement of needles and hooks ..	132
"    "    "    —Card cylinder .. .. .	135
"    "    "    —Card cylinder mechanism, action of ..	138
"    "    "    —Construction of twilling tappets and ratchet wheels .. .. .	140
"    "    "    —Lags and pegs in lieu of twilling tappets ..	141
"    "    "    —Mechanism of card and twilling cylinders	135
"    "    "    —Twilling cylinder .. .. .	137
"    "    "    —Twilling mechanism, action of ..	138
"    "    —Carver's combined 5 and 8 leaf twilling ..	145
"    "    —Carver's grouping of hooks and needles ..	148
"    "    —Scotch .. .. .	142
"    "    —Use of same cards for different widths and fineness of cloth .. .. .	150
Loom—The draw .. .. .	45
"    —The treadle .. .. .	32
Leno or gauze Jacquards .. .. .	191
London system of harness mounting .. .. .	272
Neck cords—Double necks and link motion : a comparison ..	101
Needles and hooks—Arrangement of, in a twilling Jacquard ..	132
Norwich system of harness mounting .. .. .	270
Ornamenting textiles—Methods of .. .. .	17
Pattern design—Origin and growth of .. .. .	17
"    cards—Use of same for different widths and fineness of cloth ..	150
"    production—Factors in .. .. .	38
"    —Varying the size of the .. .. .	305
Plain cloth—Plan view and details .. .. .	19
Piano card stamper .. .. .	318
Point paper—Suitable sizes for ordinary and twilling Jacquards ..	308
"    —Transferring gauze design to .. .. .	202
Pressure heddle mechanism .. .. .	183
"    harness Jacquards—Intermittent driving of .. .. .	177
"    "    shedding—Amount of dwell for .. .. .	178
"    "    weaving .. .. .	172
Problems on construction of tappets .. .. .	180
"    compound driving and value of counterpoise .. .. .	167
"    harness mounting .. .. .	303

	Page
Reed—Gauze .. .. .	211
„ —Harness .. .. .	273
„ —Tug .. .. .	214
Repeater—Card .. .. .	324
Rothwell's automatic cross border Jacquard .. .. .	123
Schroer's Index Jacquard .. .. .	245
Shed—Problems on uniform depth of, with two or more Jacquards .. .. .	112
Shedding—Bottom .. .. .	28
„ —Centre .. .. .	27
„ —Open .. .. .	30
„ —Semi-open .. .. .	30
Shaft mounting—The original compound .. .. .	54
Shedding—Pressure harness .. .. .	173
„ —Treadle, hand loom weaving .. .. .	32
Spiral springs—Work stored in .. .. .	168
Split or scale harness .. .. .	187
Swivel and Jacquard .. .. .	223
Swivel—Decoration of vestings .. .. .	225
Swivel mechanism—Details .. .. .	229
„  „ —Automatic detachment of picking mechanism .. .. .	239
„  „ —Lateral reciprocation of the swivel shuttles .. .. .	235
„  „ —Neutralising the action of the weft fork .. .. .	235
„  „ —Regular and intermittent action of the picking mechanism .. .. .	240
„  „ —Vertical reciprocation of the swivel frame .. .. .	232
„ spotting brocade and figured fabrics .. .. .	224
„ weaving—Objects and advantages of .. .. .	224
Twill—Three end, plan view and details .. .. .	19
„ —Four end, plan view and details .. .. .	19
„ —Five end satin, plan view and details .. .. .	21
„ —Eight end satin, plan view and details .. .. .	21
Tappets—Construction of, and problems on .. .. .	180, 186
„ —Operating pressure heddles by .. .. .	184
Taylor's—Double necks .. .. .	60
Twilling tappets—Lags and pegs in lieu of .. .. .	141
„ tappets and ratchets—Construction of .. .. .	140
„ cylinder—Mechanism of .. .. .	135, 137, 138
„ Jacquards—Shots per card, and point paper for .. .. .	308
„ mechanism—Hand loom .. .. .	40



INDEX.				355
				Page
Vaucanson's improvements on draw loom .. .. .	..	..	..	63
Verdol, index or Schroeier's Jacquard .. .. .	..	..	..	245
Vestings—Decoration of .. .. .	..	..	..	225
Warp shedding—Chief principles of .. .. .	..	..	..	27
"  "  —Mechanical systems of .. .. .	..	..	..	30
"  "  —Object of .. .. .	..	..	..	26
Warp and weft figures—Extra .. .. .	..	..	..	223
"  "  spotting—Relative advantages of extra .. .. .	..	..	..	223
Weaving—Fundamental principles of .. .. .	..	..	..	26
Work stored in spiral springs .. .. .	..	..	..	168
Woven fabrics—Fundamental types of .. .. .	..	..	..	18

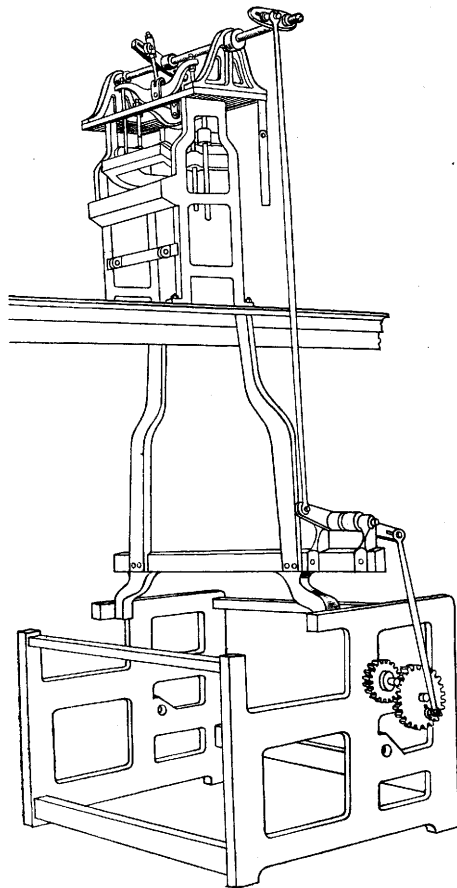


# DRACUP'S Patent Driving Motion

FOR SINGLE OR DOUBLE LIFT

## JACQUARD MACHINES.

No. 3782.



DISPENSES with the upper gantry and pillars and protruding cranks at ends of loom shafts, and thereby allows more light and accessibility to the Jacquard, gives more valuable space in the aisle, and reduces the risk of accidents.

The accompanying illustration shows the principle of the spur wheel drive from the top shaft of loom to the Jacquard, with one rocking shaft at the top of Jacquard to lift from above the machine.

Two additional modifications of this patent are also made, particulars of which can be had on application.

**Dracup's Patent Driving Motion** assures steady and accurate weaving.

It is very simple in construction; no substituting gantry being added.

The spur wheel drive can be applied to the low shaft of the loom instead of the upper if desired.

Call and see it weaving at my works.

## SAMUEL DRACUP,

JACQUARD MACHINIST AND HARNESS BUILDER,

### GREAT HORTON, BRADFORD.

Telegrams: "HARNESS, BRADFORD." Telephone 1510 Bradford. Established 1825.

# GEORGE HODGSON, LTD.,

Frizinghall Works, BRADFORD, Yorks.

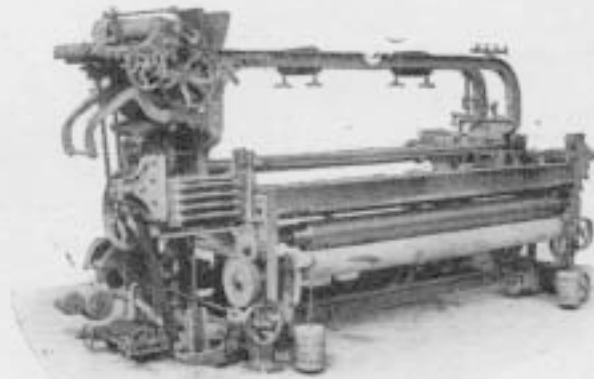
Great Improvements in

## Worsted & Woollen Weaving.

FASTER SPEEDS.

MORE PRODUCTION.

EASIER WEAVING.



THE HODGSON PATENT HIGH-SPEED PICK-AND-PICK-AT-  
WILL DROP BOX LOOM, WITH INDEPENDENT BOX  
AT EACH END, AND POSITIVE WHEEL DOBBY.

Can be seen running in the Exhibition Room, Frizinghall Works.

We have been awarded the RAPPEL DE GRAND PRIX for  
Weaving Machinery at the International Exhibition, Roubaix, 1911.

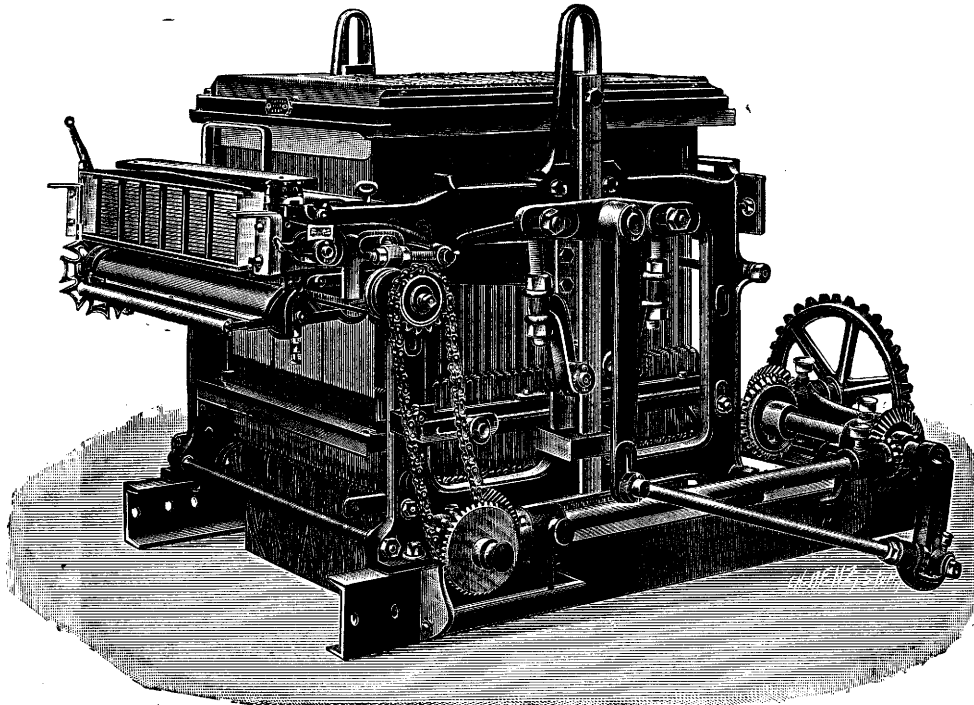
The List of Awards gained by the firm include the Highest Honours  
that can be attained. No other firm engaged solely in the manu-  
facture of Power Looms can show such a record.

Telegrams: "HODGSON, BRADFORD."

Code: A.B.C. 3th Edition

# HERM. SCHROERS, MASCHINENFABRIK, CREFELD.

Telephones No. 4554, 4555 & 4556. Cable address: Looms, Crefeld.



**Jacquard Machine, fine index, for endless paper card. Since 1893 we delivered every month 70-80 machines fine index for endless paper card.**

## SPECIALITIES.

Complete installation of silk weaving factories and all preparatory and auxiliary machinery.

Complete installation of velvet and plush factories, both looms and auxiliary machinery.

Complete installation of ribbon weaving factories, silk, cotton, etc. Small-ware, elastics, etc.

Jacquard machines, fine index for endless paper card, different patented styles, single and double lift.

Card punching and copying machinery.

Winders, quillers, doublers, especially for cross-winding, warpers, beamers, etc.

Rubbing machines with air-cushion for pure silk and half silk stuffs, velvets and plushes.

Machines for artificial silk spinning, twisting, reeling, etc.

IV  
**ROBERT HALL & SONS, BURY, LTD.**  
**BURY, England.**

---

**POWER LOOMS,**  
**JACQUARDS AND DOBBYS**

OF EVERY DESCRIPTION.



**Double Lift Jacquard.**

ALL KINDS OF  
**PREPARING AND FINISHING MACHINERY FOR WEAVING PURPOSES.**

V  
TELEGRAMS:  
"COMBE, BELFAST."

ON THE ADMIRALTY  
LIST.

# COMBE BARBOUR, BELFAST, IRELAND,

BRANCH OF  
FAIRBAIRN LAWSON COMBE BARBOUR, LIMITED.

---

MAKERS OF ALL KINDS OF MACHINERY FOR

JUTE, FLAX, HEMP, MANILA,  
AND SISAL, VIZ:—

Hacklings, Cards, Spreaders, Drawings, Rovings, Gill Spinnings, Dry Spinnings, Wet Spinnings, Twistings, Reels, Thread and Twine Polishers, Balling Machines, Bundling Presses, Fluting Machines, Lathes and all Accessory Machines required in the production of Linen Yarns and Threads.

**COP AND ROLL WINDING MACHINES.**

**BINDER TWINE MACHINERY,**

**A SPECIALITY.**

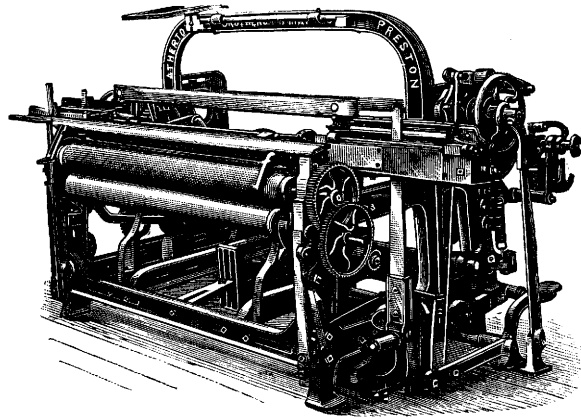
Makers of Spindles, Flyers, Screws, Bolts, Nuts, Rivets, Files, Brushes, Leather Belting, Hackles, Gills, Brass and Wood Clothing, Tin Cylinders, Brass, Steam and Water Fittings.

---

**STEAM ENGINES.    SHAFTING.    PULLEYS.**  
**HANGERS & GENERAL MILLWRIGHT WORK.**

vi

**ATHERTON BROS., LTD.,**  
**LOOM MAKERS,**  
**PRESTON.**



**85,500 LINEN LOOMS MADE AND SUPPLIED.**

**COTTON AND LINEN LOOMS**  
**AND**  
**PREPARING MACHINERY SPECIALITIES.**

---

**Over 100 different models to select from, thus giving  
a range unequalled by any other maker.**

---

**MILLS EQUIPPED THROUGHOUT.**

vii

# HENRY GREEN & SONS, LTD.,

ATLAS PAPER MILLS,  
FARNWORTH, BOLTON.

Telegraphic Address:

Telephone No. 177, Farnworth. "Green's, Devon Street, Moses Gate."



MAKERS OF ALL CLASSES OF JACQUARD CARDS.  
Speciality:—B.K. AND O.K. "ROPE" CARDS.



# PATENT DOBBIES

FOR ALL CLOTHS.



## CROSS BORDER DOBBIES

A SPECIALITY.

---

---

PRICES AND PARTICULARS

— ON APPLICATION TO —

---

---

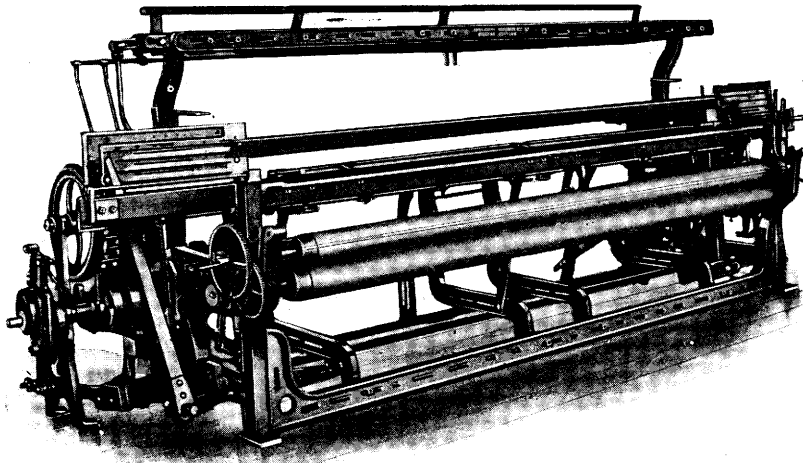
Ward Bros., Ltd.,

BLACKBURN.

TELEPHONE 360.

ix

## **NEW HARNES AND LENO, OR MADRAS LOOM.**



**Having 4 shuttle boxes on each side operated by motion on one side and controlled by 2 needles of the Jacquard machine.**

**Pick and Pick variable to any extent.**

**Gauze Reed acts only when gauzing shuttle is brought into position.**

**Jug Reed is controlled from the Gauze Reed connections.**

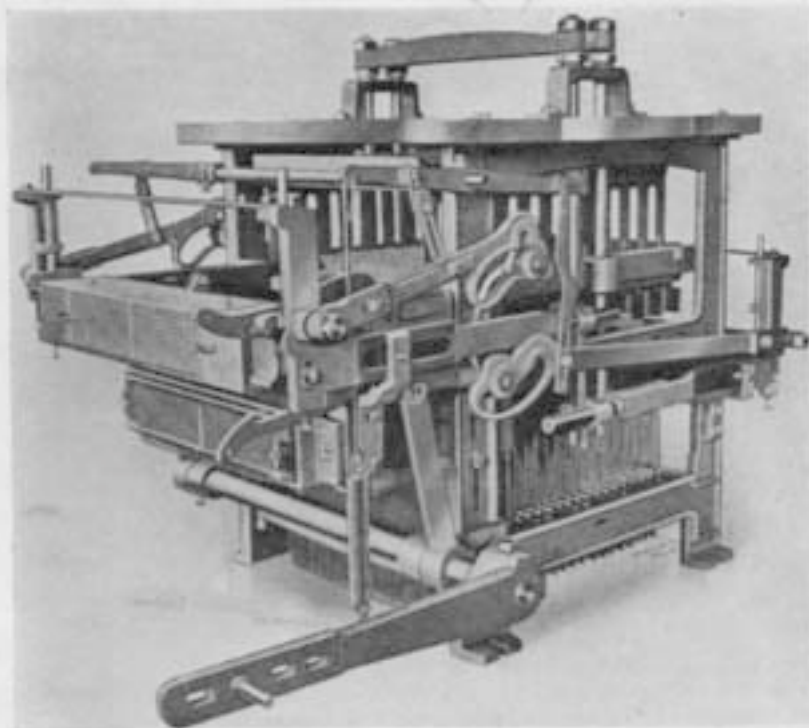
**Positive Picking Motion arranged so that pick automatically takes place on that side only where shuttle is situated. It is "fool proof" in that if shuttles are placed in boxes opposite one another, no pick can take place.**

**Send for particulars to**

**The Anderston Foundry Co. Ld.,  
GLASGOW.**

# JAMES Mc.MURDO,

JACQUARD MACHINE MAKER,  
NEW STREET, MILES PLATING, MANCHESTER.



## 600's Double-Acting Cross Border Jacquard Machine—Slide Motion.

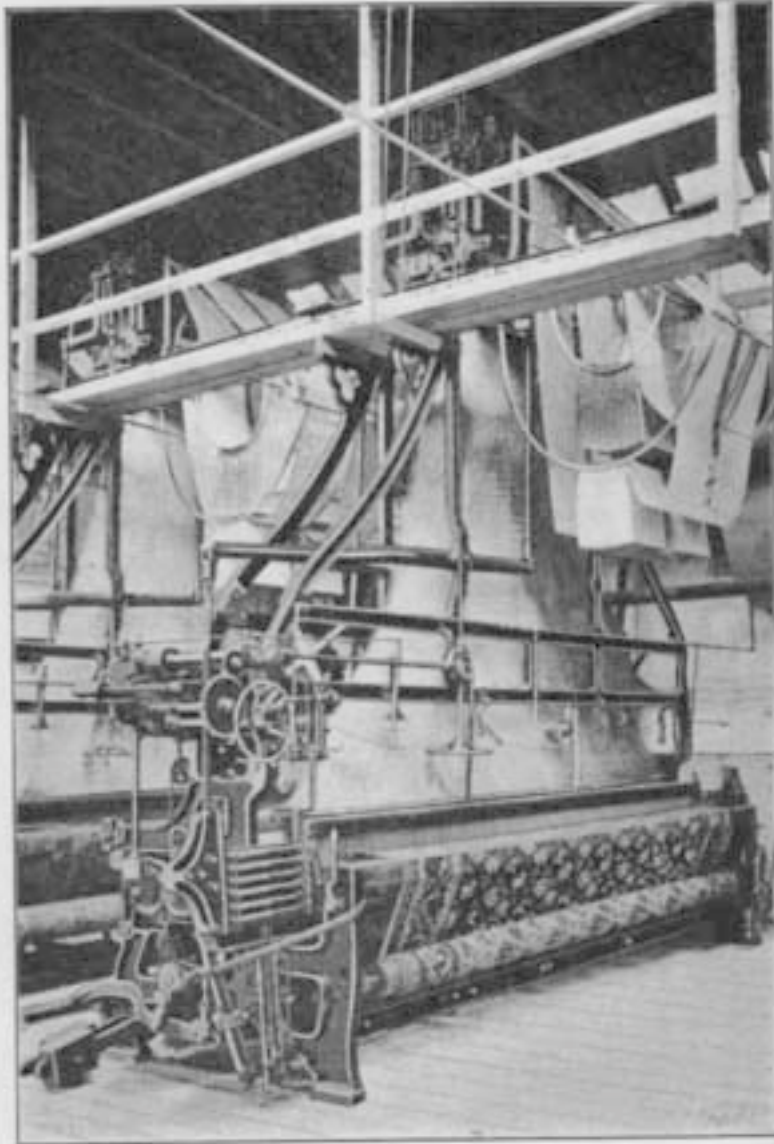
Plans Reading-in and Cutting Machines, Repeating Machines and Stamping Plates suitable for working by Hand or Power, Lead and Iron Wire Lingoes, Brass and Steel Nails, Thread, Cards, Hooks and Needles, Comberboards and Nips, and all kinds of Jacquard Sundries.

Wooden Frame Jacquard Machines for Hand Looms.

Self-Acting Repeating Machine.

Harness Builder, &c.

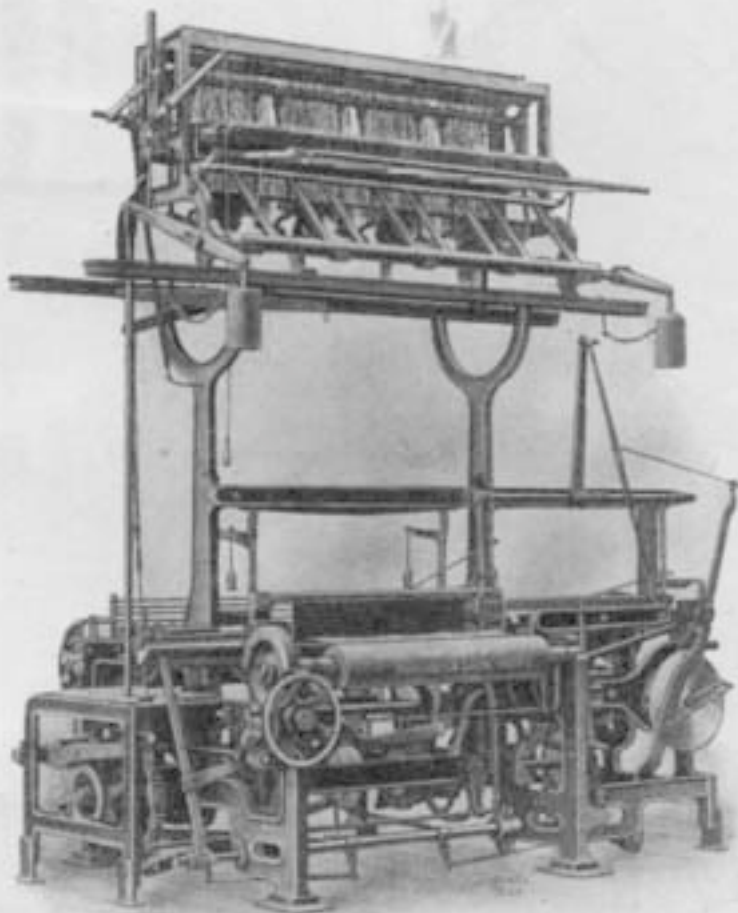
xi  
**HUTCHINSON, HOLLINGWORTH & CO., LD.,**  
**DOBCROSS LOOM WORKS,**  
**YORKSHIRE.**



INGRAIN LOOM.

# HUTCHINSON, HOLLINGWORTH & CO., LD., DOBCROSS, YORKSHIRE.

Makers of Looms for Weaving all kinds of Worsteds, Woollens, Carpets, etc.



## BRUSSELS AND WILTON CARPET LOOM.

Two or three shot, embodying Hollingworth's Patents in all widths from  $\frac{1}{2}$  up to  $\frac{3}{4}$  wide, with various kinds of wire motions, and furnished with either 5 frame, 6 frame, or 5 and 6 frame Jacquard Machines, with powerful double beat lay motions, take-up or letting-off motions, and driving motions, and embodying all the latest improvements for weaving this class of goods. In all respects a strong loom and suitable for heavy work. Also Makers of Tapestry, Tapestry Velvet, and Tapestry Velvet Table Cover Looms, in various widths.