

## WEAVING.—No. VI.

## HAND-LOOM WEAVING—(Continued).

THE reed is fixed into the lower part of a frame, called the "batten," *ee* (Fig. 27), which is suspended from two gudgeons, *ff*, and is capable of being moved a short distance to and fro, in a line parallel to the warp threads. At each side of the batten, and about level with the bottom of the openings in the reed, are placed two shuttle

boxes, *gg*. These boxes have a spindle fitted lengthways over the centre of them, upon which the picker, a kind of hammer, is made to slide. The two pickers are connected together by a slack cord *m*, to the centre of which the "picking-stick" is attached. Two short ends are connected to the picker cord to keep it suspended and free to work. The boxes are suited to the size of the shuttle, which is driven with considerable velocity from one box to the other by means of the picking stick and pickers. It is known as the fly shuttle, and was patented by John Kay in 1733. Fig. 27 shows the batten detached from the loom, in which *pp* are the pickers which slide upon the spindles *nn*, *s* the shuttle placed in the shuttle box. The pickers are variously made, but principally of hide dressed

so as to resemble horn. Fig. 28 shows a section of the batten at the centre. The picker *p* is made with a small tongue at the bottom to slide into the groove, which causes much less friction than if the pickers were made to fill the box from side to side. In the same section the reed *R* is shown pressed by flat springs, which is a contrivance added to some looms to regulate the force of the blow of the batten. There are two of these springs, one at each end of the reed, and they are attached

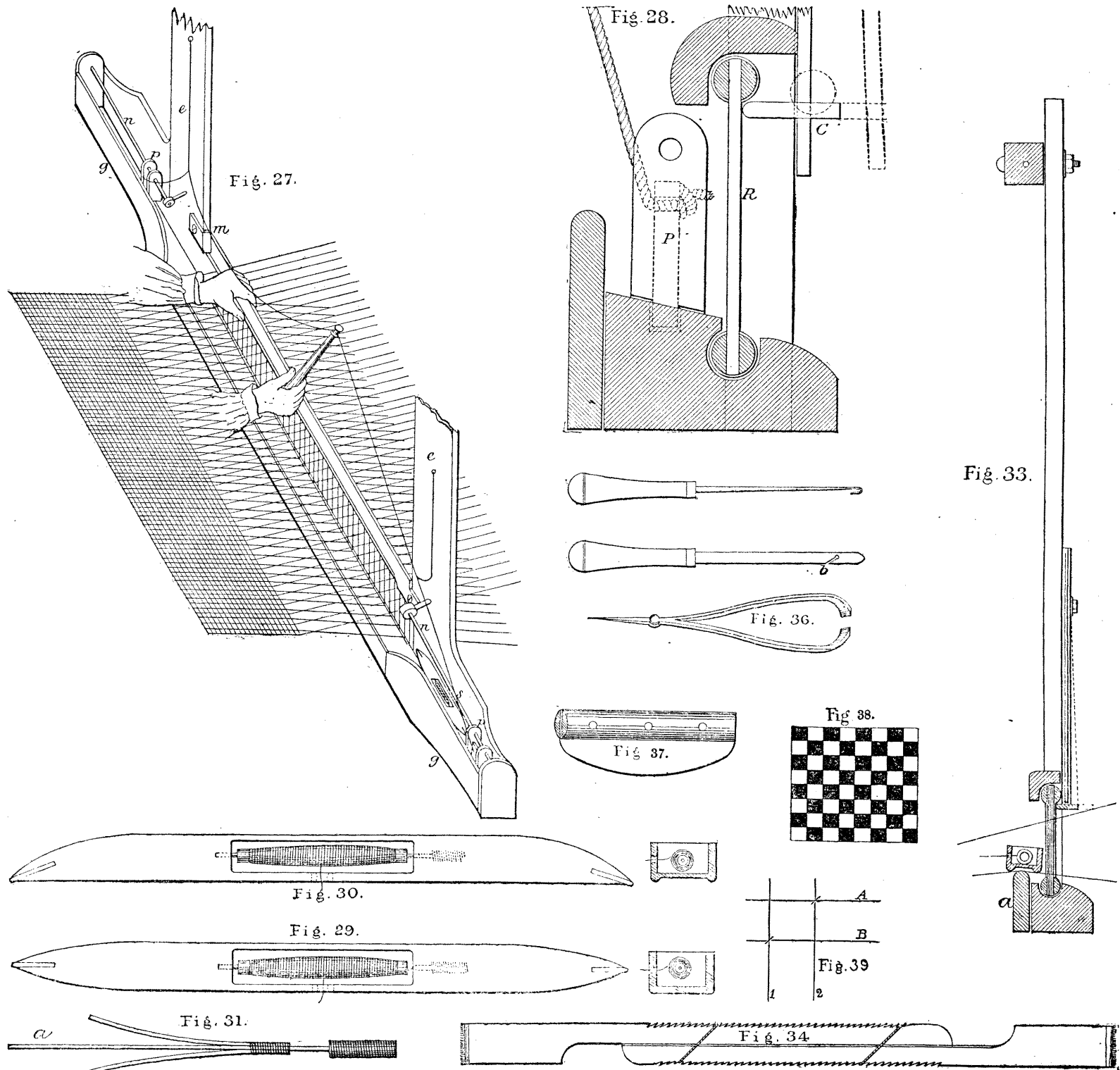

boxes, *gg*. These boxes have a spindle fitted lengthways over the centre of them, upon which the picker, a kind of hammer, is made to slide. The two pickers are connected together by a slack cord *m*, to the centre of which the "picking-stick" is attached. Two short ends are connected to the picker cord to keep it suspended and free to work.

The boxes are suited to the size of the shuttle, which is driven with considerable velocity from one box to the other by means of the picking stick and pickers. It is known as the fly shuttle, and was patented by John Kay in 1733. Fig. 27 shows the batten detached from the loom, in which *pp* are the pickers which slide upon the spindles *nn*, *s* the shuttle placed in the shuttle box. The pickers are variously made, but principally of hide dressed

to the presser at *c*. A screw is placed to regulate the strain according to the strength required. When the blow is given to beat the weft threads together, the reed, being pressed by the springs, gives way if too heavy a blow be struck, and thereby insures a greater amount of uniformity, and prevents thick and thin places in the cloth, which in the absence of a "take up motion" would be likely to occur.

The loom being ready for the actual operation of weaving, the weaver takes his seat, and places the shuttle into one of the boxes, after pushing the picker back to the far end of the box. A short length of the weft thread is allowed to hang out of the eye of the shuttle, so that it may be caught on the edge of the warp as the shuttle enters the shed for the first time. He then takes hold of the batten

by the left hand in the position shown in Fig. 27, and holds the picking stick in his right hand.

In the sketch the shuttle is shown to be in the right-hand box; in this case the weaver places his right foot upon the right treadle, and depresses it, which, at the same time, causes the left treadle to rise, and an opening or shed is formed in the warp, as shown in the figure. He first pushes the batten backwards a few inches, which causes the opening in the warp to appear in front of the reed, as well as at the back, and thus gives room for the shuttle. He next, with a smart jerk of the right hand, throws the shuttle through the warp and into the opposite shuttle box, where it comes into contact with the picker, and drives it to the far end of the box. Then he draws the batten towards him, which brings with it in front of the reed the weft thread. He

hand is at the present time in frequent use, but principally among silk weavers. The fly shuttle is made straight in form, as shown at Fig. 29. It is usually made of boxwood, and is tipped at each end with smooth steel points. There is an oblong hole morticed out of the shuttle for the reception of the weft bobbin. In silk weaving this bobbin is called a quill, but is generally made of a small reed about the length of a quill barrel. The reed still retains the name of quill, although quills are not used now, owing to their extra cost. The reed or quill is fixed upon a small wire spindle, which is shown at *a*, Fig. 31. There are two small wire springs attached to it, which are not only for the purpose of holding the quill in position when placed on the spindle, but cause a slight friction to the quill and thereby a slight tension on the thread. The spindle

shuttle through an eye made of glass or earthenware, which is fixed there for the purpose.

The shuttle, when thrown by hand, is somewhat curved, as shown at Fig. 30, which form is more suitable to follow the motion of the hand. Fig. 32 shows the method of throwing it. It will be seen that the thumb is placed on the shuttle race whilst the hand is held open below it to catch the shuttle. The batten is drawn towards the weaver by the thumb, although it naturally falls towards him by its own gravity, being usually worked a little out of a vertical line for that purpose. Sometimes springs are placed to draw the batten forward, in which case the weaver, with the back of the hand merely, pushes the batten backwards, whilst the spring gives the blow.

Fig. 33 shows a section of the shuttle and the shuttle race, or bed, upon which it slides. It will be seen the warp threads are pressed down upon the race *a*, and the shuttle (Fig. 30), having a wide shallow groove, slides upon the ridge of the warp threads, as shown in section.

It has been shown that the ends of the warp threads are secured to the cloth beam by being inserted into a groove. The beam is held in position by means of ratchet wheel and pawl, and as the cloth is woven it is wound up by means of a short lever. In order to keep the warp threads of a proper degree of tension, the warp beam is provided with two weights, or two pairs of weights, one being much heavier than the other, and attached to the same cord, the heaviest weight being hung so as to draw the warp in a contrary direction to the cloth beam, and thereby cause the tension upon the threads. The rope to which the weights are attached is wound round the warp beam several times to give it sufficient friction. Now when the treadles are depressed, and the shed is opened for the passage of the shuttle, the heavier weight is slightly raised, and falls again when the shed is closed. As the cloth is woven, the weight is gradually drawn upwards, and the small counterpoise falls. When this latter touches the ground it follows that the rope becomes slackened, and thereby takes the friction off the rope, and allows the warp beam to move, although the tension caused by the heavier weight is always acting upon the warp.

This motion is made in many different forms, sometimes by means of levers, in which case the weights can be adjusted to any degree of tension. The tension, as the warp becomes unwound, becomes greater, through the diameter of the beam being lessened, whilst the weight remains working at the same leverage. Thus it requires occasional adjustment in weaving very long warps, where the diameter of the warp beam may become lessened perhaps one half in diameter. This circumstance has given rise to "let-off motions" being continued to equalise the strains, but they will be referred to in power-loom weaving, where their use is of more importance.

In like manner the take-up motion is effected in the same way. In hand-loom weaving the weaver draws the cloth beam round occasionally, after weaving a few inches. In power-loom weaving this becomes a very important matter, and a great variety of motions have been invented to overcome the difficulty, several of which we intend to describe. A take-up motion has been introduced in hand looms, which we shall hereafter notice under the subject of figure weaving.

In the process of weaving it is found that some cloth as it is woven has a tendency to draw in or become narrower. This effect requires to be counteracted, otherwise very irregular work would be the result. The contrivance used for the purpose is called a "temple," and they have been made in a great variety of forms, but for hand-loom purposes a very simple form suffices. Fig. 34 represents a common form of temple. It consists of two flat pieces of wood, adjusted and laced together according to the width of the cloth, by a cord as shown. At both ends of the temple a number of pin points are fixed. These points are placed in the two selvages of the cloth, and it is thereby held stretched out and prevented from contracting, as it would otherwise do. As the cloth is woven the temple is moved. Fig. 21 (see page 367 *ante*) shows the temple as it lies upon the cloth at *S*. In power-loom weaving the temples are made to revolve, so as to require no refixing as the cloth is woven.

The machines used by the hand-loom weaver, in addition to the loom, are the hand wheel and a pair of small reels, as shown at Fig. 35. If he has to

then treads upon the left treadle, and at the same time pushes the batten backwards, which opens the shed ready for throwing the shuttle back to the right-hand box. When the shuttle is thrown he again draws the batten towards him, which pushes the weft thread against the last thread, or shute. Thus the operation is continued, the three motions, viz., opening the shed by means of the treadles, throwing the shuttle, and beating together the weft threads by the reed which binds them together compactly and evenly, which is necessary to the production of cloth.

Although the fly shuttle has been in use since 1733, still the old mode of throwing the shuttle by

and spring or springs are often made from one piece of wire by turning one or both ends, similar to a single or double hook flattened. The spring must be weak enough to allow the quill to move longitudinally as well as upon its axis, and the spindle is fixed stationary, and without movement. When the spindle is placed in the shuttle one end is pressed against the concealed spring, which causes it to be pushed inwards, and thereby allows of the other end of the spindle to be inserted into the hole at the opposite end of the mortice hole. The spring now presses against the spindle and keeps it in its place, until it is necessary to renew the quill. The weft thread is made to pass out at the side of the

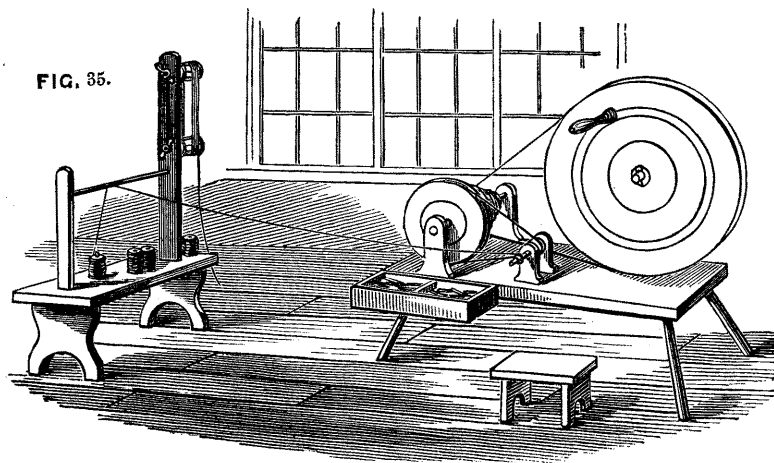
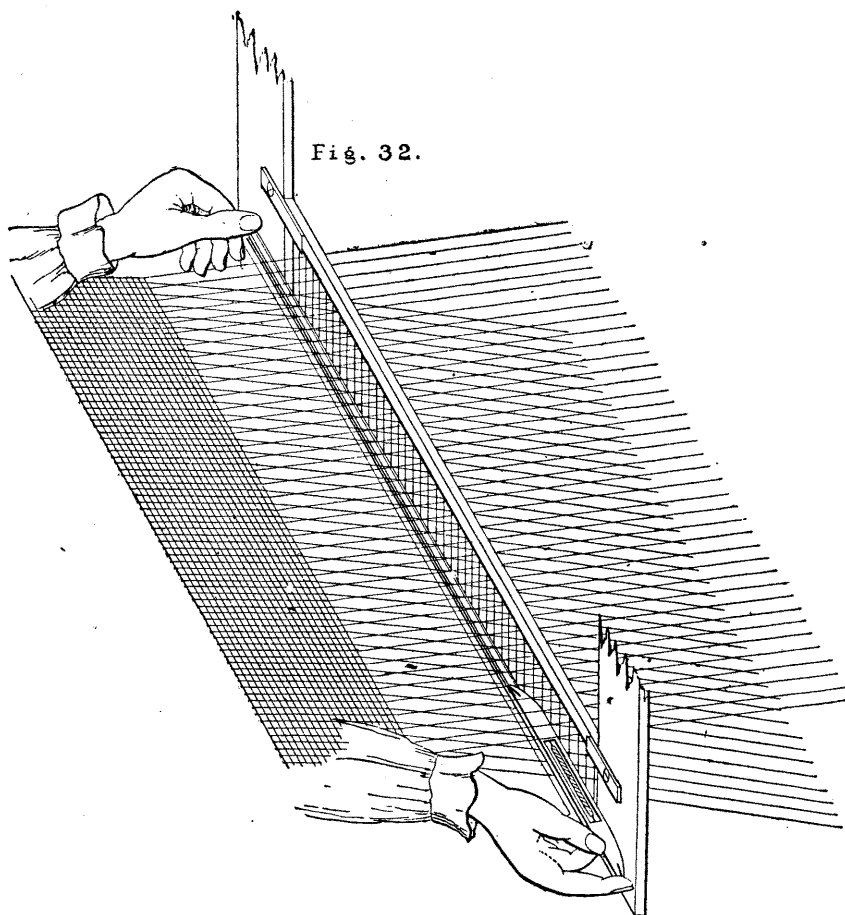

unwind the weft from skeins, he generally winds it upon bobbins first, and from the bobbins he winds it upon the quills. These operations simply consist in placing the bobbin or quill upon the spindle of the hand wheel, and winding upon it the weft thread either in double or single threads, as may be required.

We may here mention two small implements in constant requisition by the weaver and shown in Fig. 36. In the first of these, employed to draw the warp threads through the reed, a hook is used made of a strip of flat metal, with a notch in it, as shown at *d*. But he can in hand looms very easily draw it through the reed without the aid of the hook, which is done by turning the broken thread round the adjoining thread, which occupies the same opening in the reed, when by pushing back the reed, the thread passes between the dents, and he then joins it to the surface of the cloth, and it becomes woven in on the next throw of the shuttle. The second instrument in general use is a small pair of spring nippers *e*, with a point at one end. With these he can cut off any short ends or knots, &c.

For drawing the threads through the mails a small-hook is used, and a rubber (Fig. 37) made of flat steel is used for smoothing the cloth.

Each throw of the shuttle is called a "pick," consequently the loom is counted in speed by the number of "picks" per minute. The number of weft threads, also, is named in the same way, and is counted as so many picks to the inch. Sometimes the words shoot and shute are used instead of pick and weft.

In Fig. 8 (see *ante* page 302) a piece of plain woven cloth is represented as before stated. Fig. 38 represents the same thing as it would be drawn by the designer, and it is generally called "tabby" or plain weaving.

In arranging the loom the weaver employs another method of drawing the pattern, and in this case he would represent it as shown at Fig. 39, in which A and B represent the two headles, and 1 and 2 the treadles. The mark placed at the intersection of the lines show which of the treadles and headles are connected together. This method becomes a matter of great importance when a number of headles are used, as will be shown hereafter.

In recapitulating the various matters concerning plain weaving, it will be evident that the process simply depends upon but very few movements. The throwing of the shuttle, working the batten, and regulating the winding up of the cloth, are the three operations which remain the same in all classes of plain and figured weaving. They may be modified in various ways, still they are dependent upon the same principles.

It is a very different matter as regards the opening of the shed for the passage of the shuttle. In plain weaving each of the headles commands half of the warp, one of them being able to raise every odd number of the warp threads, and the other head raises the even numbers. The shedding, therefore, is limited to two motions only, but they are performed in the most perfect way, namely, half of the threads are rising whilst the other are falling. Consequently they not only balance themselves in working, but the motion is effected in the least possible time. The most perfect loom is that in which each individual thread of the warp can be moved separately, or in combination order or extent, and it is in the great variety of means and ingenuity displayed in approaching this perfection upon which the power of the loom depends, while at the same time the motions should be accomplished in the least possible time, not only on account of the steady working and speed of the loom, but to do away with as much as possible the additional friction which imperfect motions give rise to.