

a long period as the best in the French Navy; this frigate rendered great service during the Crimean War. The general arrangements are shown in Figs. 263 to 265, page 194; the indicated horse-power was 1950.

Engines of the "St. Laurent" (Figs. 266 and 267, page 195).—The engines for the mail boat *St. Laurent* were built by Messrs. Schneider and Co. in 1865 for the Compagnie Générale Transatlantique for their New York service. The *St. Laurent* was the first screw steamer of this company.

The illustrations show the general arrangements of the engines, which consisted of two horizontal cylinders with toothed wheel gearing. The nominal horse-power was 850, and the number of revolutions of shaft 40 per minute, the number of revolutions of propeller being 70 per minute. Steam distribution was by means of slide valves and Stephenson link motion. The linear speed of pistons per second averaged 1.750 metre (5 ft. 9 in.).

AMERICAN SOCIETY OF MECHANICAL ENGINEERS.

(FROM OUR NEW YORK CORRESPONDENT.)

(Continued from page 172.)

THE next paper was of a historical character, and will be very difficult to condense, although your correspondent will try to do so. That is the great difficulty with anything historical; one may omit the very part someone wants to know about. However, just now the United States is busily engaged in making history, so her citizens might be expected to do something at it on their own account.

A CENTURY OF COTTON GINNING AND BALING.

The paper in question was entitled "One Hundred Years of Ginning and Baling Cotton," and the author was George A. Lowry, of Boston. He started with the product of Sea Island cotton in 1784, shipped to Liverpool, consisting of eight bags; up to 1791, when Whitney invented the cotton gin; 1 lb. a day was all an operator could clean. In two years the product was 5,000,000 lb., and in 1897 it was 5,500,000 lb. The author described the Whitney gin, shown in Fig. 9, as follows:

The original Whitney gin consisted of a drum with rows of wire hooks, or teeth, inserted in line around it. As the drum revolved, these teeth passed between a grate, or grid, the bars of which were sufficiently far apart to permit the teeth to pass without touching, but so close that the seed could not pass between. Another grate, wide enough to allow the cleaned seeds to drop through, was mounted to form a hopper for the seed cotton, and hold it against the revolving drum. The revolution of the drum, coupled with the drawing action of the teeth against the cotton in the hopper, caused the cotton also to revolve and form into a roll, thus resulting in continually presenting new material to the teeth, and giving the cleaned seed a chance to drop through the wider grate forming the hopper. As the teeth, or hooks, passed through the roll, they became charged with filaments of cotton, and the seed being held back, either by the surrounding material pressing against it, or by its contact with the forward grate, caused the filaments to be detached from the seed and carried forward by the drum, until they were removed by a brush revolving with greater rapidity in an opposite direction, and in such a manner, that the bristles brushed the teeth in the direction in which they were inclined. This removed the filaments of cotton from the drum, and the speed of the brush was sufficient to clear itself by centrifugal action. As will be seen by the accompanying drawing (see Fig. 9), the Whitney brush was four-armed.

Numberless patents have been issued, and a few improvements made on the Whitney gin, but the principle remains the same. Instead of the wire teeth fixed in a drum, we have teeth cut out of a circular metal plate. The brush consists of a drum, with rows of bristles inserted lengthwise across it, and with wings on the end to give an air current. Rotating plates have been placed at the ends of the cotton roll to reduce the friction and assist it in revolving, and perhaps the most important improvement is the mote board,* which regulates the current of air produced by the wings on the brush so nicely that the current is just strong enough to carry off the cleaned cotton, but not enough to carry off the motes, or immature seeds, which thus become separated as wheat is from chaff. The addition of this air current, and the passing of the cotton through flues to a lint room, or condenser, also materially assists in opening up the neps occasionally caused by the films of cotton doubling around the teeth and becoming snarled. The lint room was merely a large compartment, or box fitted with screen ventilators, into which the cotton was blown, the ventilators allowing the air and dust to pass away.

In 1878 a condenser was added, and made a part of the gin. This condenser is a revolving screen, and as the

* Invented by Eleazer Carver in 1845.

COTTON GINNING AND BALING.

cotton is blown against it, the air passes through, leaving the lint on the face of the screen in the form of a bat, the air passing out through the bottom and ends of the condenser and carrying the dust and dirt with it; the screen, as it revolves, constantly presenting new surfaces to the oncoming cotton. A bat roll is placed over the top of the revolving screen and lifts the cotton from it, delivering it into a chute.

Figs. 10 and 11 show the gin with the improved brush and lint room as made in 1843.

Fig. 12 shows the gin and condenser as manufactured at the present day.

The capacity of a roller gin is about 400 lb. daily. The capacity of the improved Whitney gin is 4000 lb. per day. A roller gin consumes 71,000 foot-pounds of power for each pound of clean cotton, as against 35,000 foot-pounds on a Whitney gin for the same quantity.

The author compared the Whitney gin, called "saw gin" (because of the teeth set in a circular disc) with the roller gin as follows:

	2.5 per cent.	degree of neppiness from roller gins.
	2.7	" " " saw gins.
Cleanness:		
	0.8 per cent.	of leaf from roller gins.
	0.00	" " saw gins.
	1.2 per cent.	of crushed seed from saw gins.
	1.5	" " roller gins.

As the greater part of the cotton crop has to be shipped many thousand miles, attempts have been made to condense it so as to save expense. The first system used in 1780 is shown in Fig. 9, condensing to 5 lb. per cubic foot, and this was succeeded by the press (Fig. 10), condensing to 8 lb., then power screw presses (Fig. 13) condensed to 12 lb. Steam presses followed (the latest is shown in Fig. 14), having a pressure of 5 to 6 million pounds on each bale, or 2800 lb. per square inch, and reducing the bale to 60 lb. density; but from expansion when released, the average is but 22½ lb. per cubic foot. In Fig. 15 the form of press used in cylindrical bales, is shown with the Bessonette improvements of 1893.

The latest form of press is shown in Fig. 12, and the principle involved is entirely new:

The press consists of an inner sleeve, 19 in. inside diameter at the top, and drawn in to 18 in. in the first 12 in. of length. This sleeve has a collar or flange, and revolves on antifriction bearings on the shoulders of the stationary outer casing. Bolted to this outer casing is a slotted cap-plate. The slots are ½ in. wide, and run radially from within an inch of the centre to the outer diameter of the sleeve. Eight slots are used on the present machine. On the inner sleeve is mounted a spur gear, by which the sleeve is made to revolve, and a drawn-steel tube, to carry the bag for the reception of the cotton, is attached to the sleeve by a flange. In operation, the sleeve is first filled with cotton, sufficiently tight to give some pressure against the cap-plate; the cotton, as it comes from the gins and condenser, falls on the cap-plate, and some of the fibres become engaged with the cotton moving underneath the slots. These fibres draw in other fibres, with which they are interlaced, and in this way the whole body of cotton on the cap-plate is soon engaged and kept moving towards the slots. As the cotton is drawn around the lips of the slots, the upward pressure of the material in the sleeve squeezes out the air and compresses the fibres, and there is no opportunity for re-expansion; this continuous introduction of new material forces the material already in the chamber downward. The narrowing of the diameter, or otherwise the choke in the sleeve, together with the length of the tube, gives the resistance which regulates the density of the bale. To give a greater or lesser density the choke is increased or decreased, and the tube lengthened or shortened. With this machine, and an exertion of 25 horse-power, cotton has been compressed to a density of 86 lb. per cubic foot. (Oak is but 54 lb. to the cubic foot.) But in practice the bales are only made to a density of 50 lb. per cubic foot, as that is sufficient for the full utilization of any shipping space. By taking in a very thin bat of cotton, only a small amount of pressure is needed to compress it to the required density; the large compresses find it necessary to obtain a pressure of 2800 lb. to the square inch to compress a full-sized bale to 22 lb. density, and the American Cotton Company with a thicker bat require 1000 lb. pressure to obtain a density of 30 lb., while with this thin bat only 60 lb. pressure to the square inch is required to compress the cotton to a density of 50 lb. to the cubic foot.

These machines have a capacity of 2000 lb. per hour at a speed of 14 revolutions per minute. When opened the bales spring apart and save much labour at the mills.

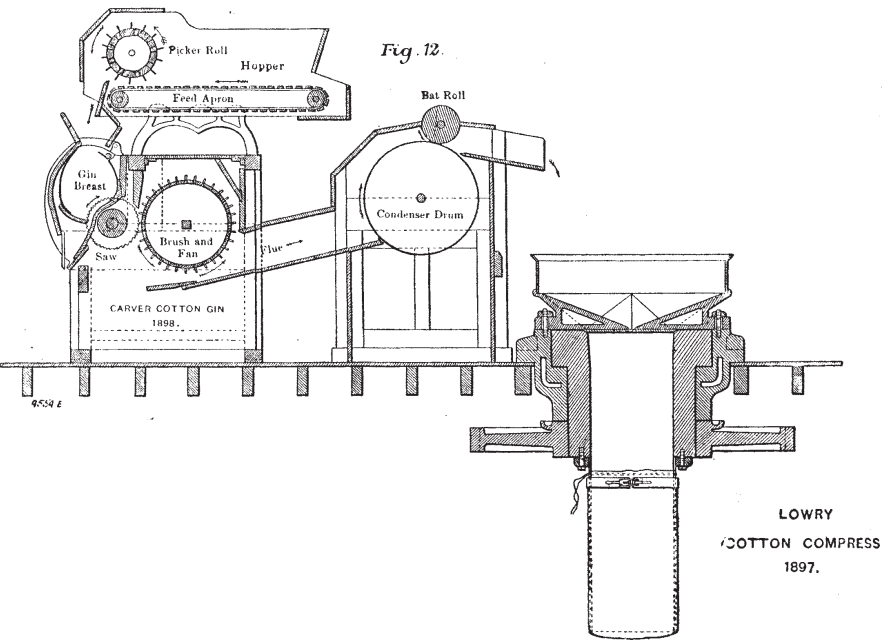
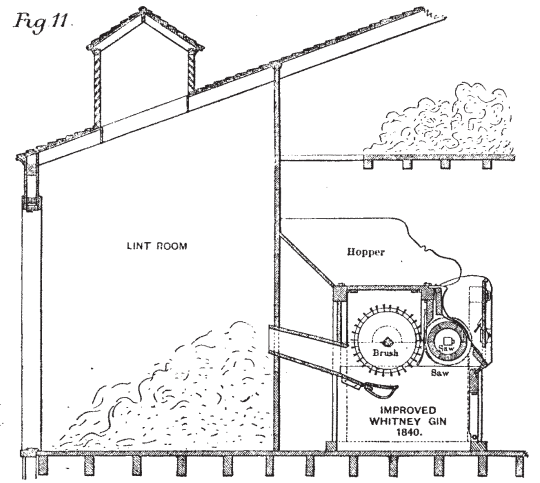
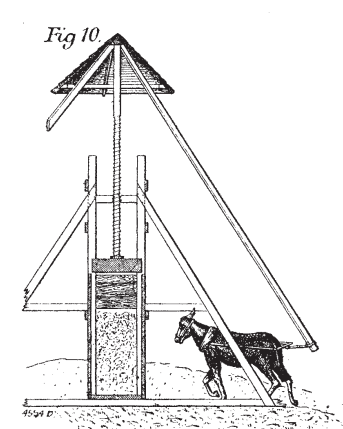
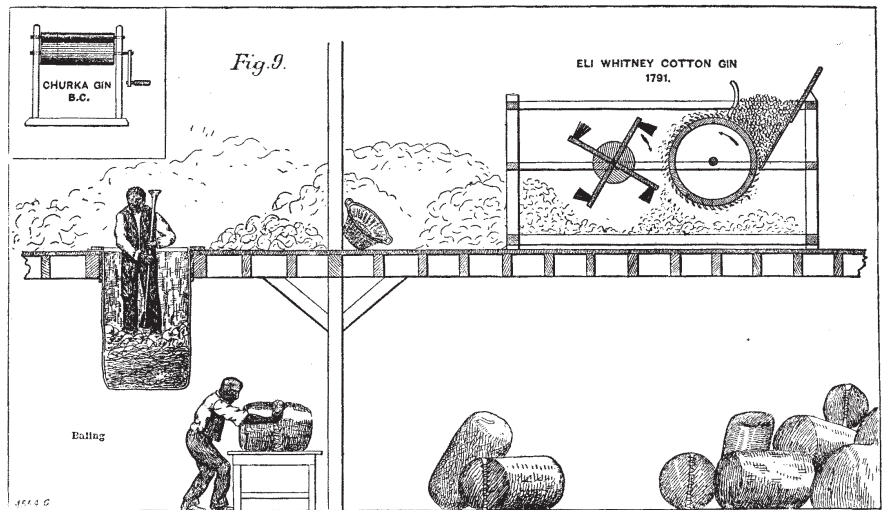

COTTON GINNING AND BALING.

(For Description, see Page 198.)

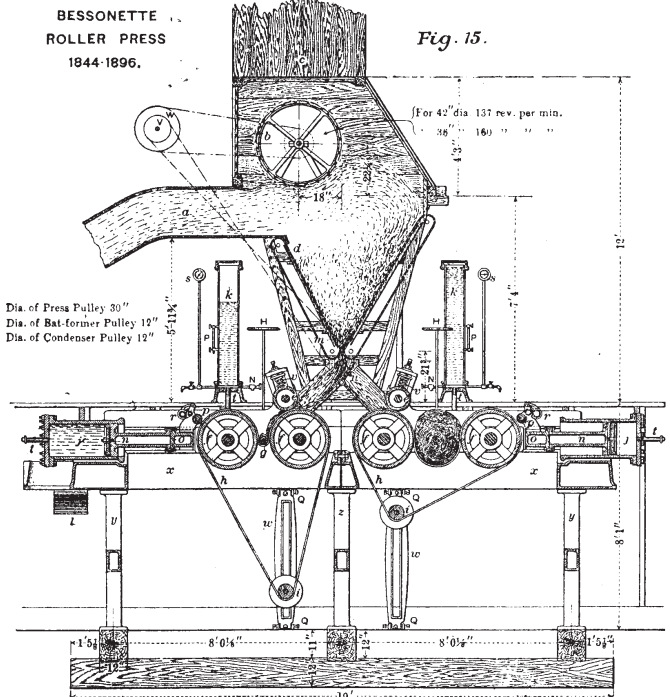
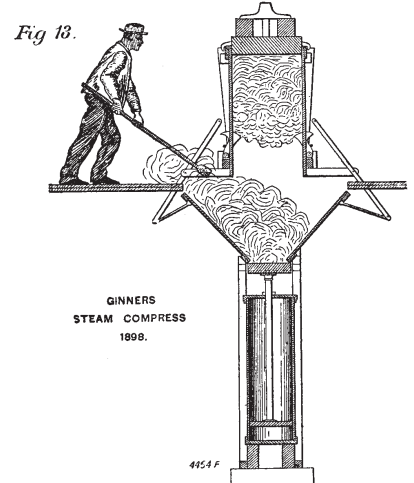
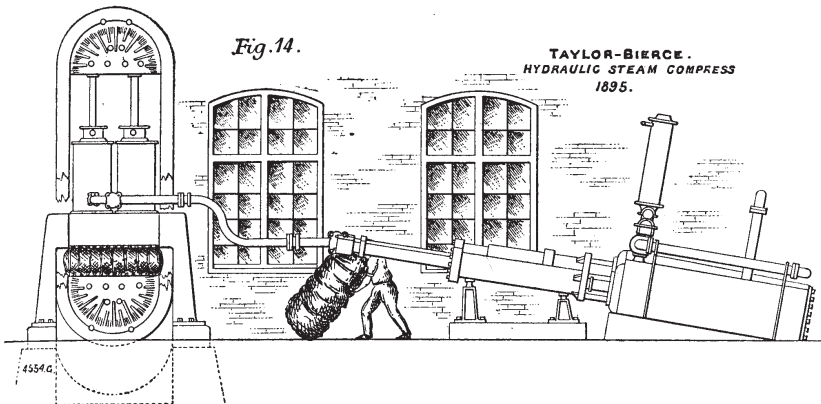

- Section of Double Press, Bat former and Condenser.
- a — Lint flue.
 - b — Condenser drum.
 - c — Dust flue.
 - d d — Bat-former aprons.
 - e e — Compression rolls.
 - f f f f — Baling rolls.
 - g g — Cores. (see #)
 - h h — Baling belts.
 - i i — Belt idler.
 - j j — Hydraulic cylinders.
 - k k — Pressure column.
 - l — Press pulley.
 - m — Bat former pulley.
 - n n — Piston rod.
 - p p r r — Tension rolls.
 - s s — Pressure gauges.
 - u — Swinging chute.
 - w w — Guides for belt idler.
 - N N — Pressure regulators.