

Recent Textile Patents.

BLEACHING YARN COPS. 739,751. John E. Bland and Edward J. Gilligan, Pawtucket, R. I., assignors of one-half to Edward W. McDuff and Frank J. McDuff, Pawtucket, R. I.

BOBBIN HOLDER. 737,050. Simon W. Wardwell, Providence, R. I., assignor to Universal Winding Co., Portland, Me.

BRAIDING MACHINE SPINDLE. 738,383. Louis W. Whitehead, Manchester, England.

CLOTH CUTTER. 737,768. James T. Preston, Filley, Mo.

CLOTH TENTERING MACHINE. Stop Motion. 737,910. John L. Dabbs, Rockhill, S. C., assignor of one-half to John R. London, Rockhill, S. C.

COMBING MACHINE. Stop Motion. 737,268. Oscar L. Owen, Whitinsville, Mass., assignor to Whitin Machine Works, Inc., Whitinsville, Mass.

Cotton Opening and Cleaning Machine. 735,076. Richard E. Evans, New Hartford, N Y.

This invention provides an improvement in machines for opening and cleaning cotton or other fibrous material, which will reduce the amount of waste in such machines as heretofore constructed and at the same time not decrease the capacity or efficiency of the machine.

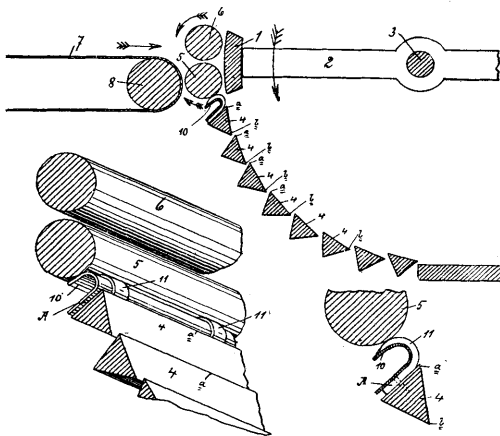

COTTON OPENING AND CLEANING MACHINE. 739,246. David J. Winn, Sumter, S. C.

COMBING MACHINE Drawing-Off Attachment. 730,021. Walter B. Jefferson, Philadelphia, Pa., assignor of one-half to Edward Jefferson and Mordecai Jefferson, Philadelphia, Pa.

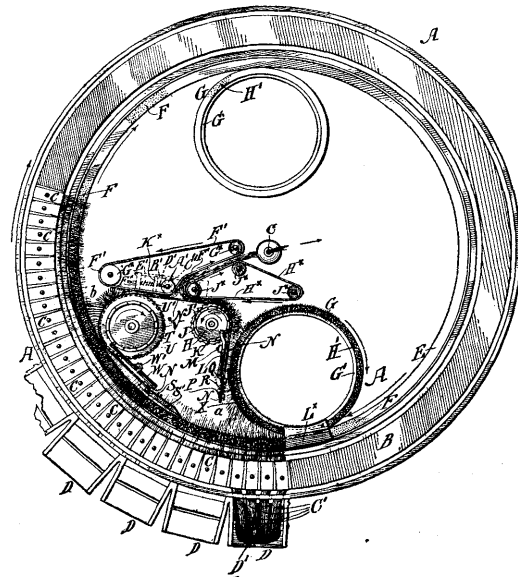

This invention relates to improvements in drawing-off attachments for combing-machines, and consists of means whereby the endless aprons between which the long strands or "tops" pass are not subjected to the strain which they undergo at present, thereby prolonging the working qualities of the aprons and reducing to a minimum the necessity of replacing broken or worn-out aprons.

DRAWING FRAMES. Shipper Lock for 737,862. Henry A. and Oscar L. Owen, Whitinsville, Mass., assignors to Whitin Machine Works, Whitinsville, Mass.

DRAWING FRAMES. Shipper Lock for 737,863. Henry A. and Oscar L. Owen, Whitinsville,

- Mass., assignors to Whitin Machine Works, Whitinsville, Mass.
- FABRIC. 737,751. Amanda M. Lougee, Boston, Mass.
- FABRIC PICKING TABLE. 737,990. Emil Zenger, Scranton, Pa.
- FLAX BREAKING MACHINE. 738,893. George H. Ellis, Chicago, Ill., assignor to William Deering, Chicago, Ill.
- FLAX STRAW PREPARING MACHINE. 738,783. George H. Ellis, Chicago, Ill., assignor to William Deering, Chicago, Ill.
- KNITTING MACHINE. 739,708. Edward Parkinson, Philadelphia, Pa.
- LOOM. 737,837. Charles A. Herald, Hamilton, Canada.
- LOOM. 737,002. Benjamin F. McGuiness, Worcester, Mass., assignor to Crompton & Knowles Loom Works, Worcester, Mass.
- LOOM. 739,651. Randolph Crompton, Worcester, Mass.
- LOOM FOR BEADWORK. 737,073. Edwin J. Bush, New York, N. Y.
- LOOM FOR CROSS WEAVING. 737,865. Isaac E. Palmer, Middletown, Conn.
- LOOM Filling-Replenishing. 739,113. Orren A. Sawyer, Lowell, Mass., assignor to Draper Co., Hopedale, Mass.
- LOOM LET-OFF AND TAKE-UP MECHANISM. 737,938. William F. Kintzing, New Freedom, Pa.
- LOOM PICKER MOTION. 739,526. Alfred H. Whatley, Providence, R. I., assignor to James Meers, Cumberland Hill, R. I., and George Reader, Providence, R. I.
- LOOM PICKER STICK CHECK. 737,219. Eli H. Gleason, Putnam, Conn.
- LOOM PILE WIRE RETAINER. 738,031. Harry Hardwick, Philadelphia, Pa.
- LOOM SHED FORMING MECHANISM. 737-148. Charles F. Roper, Hopedale, Mass., assignor to Draper Co., Hopedale, Mass.
- LOOM SHED FORMING MECHANISM. 737-149. Charles F. Roper, Hopedale, Mass., assignor to Draper Co., Hopedale, Mass.
- LOOM SHUTTLE. 738,987. Bernard Crossley, Burnley, England.
- LOOM SHUTTLE CHANGING MECHANISM. 737,520. Albert Walker, Arthur Walker and George Walker, Norwood Green, England.
- LOOM SHUTTLE CHECKING MECHANISM. 738,255. Joseph E. Tichon, New Bedford, Mass., assignor to Draper Co., Hopedale, Mass.
- LOOM SHUTTLE DETECTING MEANS. 738,249. Isaac Snow, Lawrence, Mass., assignor to Draper Co., Hopedale, Mass.
- LOOM SHUTTLE LOCK. 739,018. Francis A. Mills, Lawrence, Mass., assignor of one-half to Grosvenor B. Emmons, Methuen, Mass.
- LOOM SHUTTLE MOTION. 737,939. William F. Kintzing, New Freedom, Pa.
- LOOM SWEEP STRAP. 737,266. Charles P. Nichols, Cranston, R. I.
- LOOM TAKE-UP MECHANISM. 738,245. Orren A. Sawyer, Lowell, Mass., assignor to Draper Co., Hopedale, Mass.
- LOOM WARP STOP MOTION. 737,544. James H. Wolger, Methuen, Mass., assignor of two-thirds to Samuel C. Foss and Charles E. Collins, Methuen, Mass.
- LOOM WEFT REPLENISHING and Controlling Mechanism. 739,573. William H. Baker, Central Falls, R. I., and Frederic E. Kip, Montclair, N. J.
- LOOM WEFT REPLENISHING Mechanism. 738,644. Albert E. Arthur and George Walker, Norwood Green, England.
- MANGLE. 738,448. Gottlieb Horig, Lawrence, Mass.
- MEASURING MECHANISM for Warpers. 737-405. Henry Hebert, Fall River, Mass., assignor to Draper Co., Hopedale, Mass.
- MERCERIZING APPARATUS. 739,580. Robin Boral and Alfred Kymer, Middleton, England, assignors to the Windsor Company, N. Y.
- MERCERIZING APPARATUS. 734,333. Paul Jeanmaire, Mulhouse, Germany.
- PILE FABRIC. Woven. 731,433. Richard S. Cookson and Henry Cookson, Philadelphia, Pa.
- PRINTING APPARATUS. Yarn. 732,001. Charles L. Horack, New York City, assignor to Fabric Coloring Company, New York City.
- SPINNING FRAME TOP ROLL. 739,014. John J. Weiss, Worcester, Mass., assignor to himself and Louis F. Weiss, Worcester, Mass.
- SPINNING FRAMES. Automatic Thread Board Lifter. 737,084. Narcisse N. S. Daudelin, Fall River, Mass.
- SPINNING FRAMES, Shipper Lock for. 737,864. Henry A. and Oscar L. Owen, Whitinsville, Mass., assignors to Whitin Machine Works, Whitinsville, Mass.
- SPINNING RING. 739,739. Michael E. Sullivan, New Bedford, Mass., assignor to the Draper Co., Hopedale, Mass.
- WOVEN FABRIC. 738,218. Harry J. Mackintosh and Robert R. Tweed, Audubon, N. J.
- YARN, Manufacturing Cotton. 738,040. Henry W. Kearns, Accrington, Eng.
- Wool Washing Machine. 735,359. Harry S. Frank, Providence, R. I.

This invention has reference to an improvement in machines for washing wool. It consists of a peculiar and novel arrangement and combination whereby the wool is subjected to the washing process in vertical tanks and the washing liquor is circulated through the floating wool.

